

Decorative
Fans

Luminarias Profesionales

Luminarias Profesionales

LED
LIGHTS
COZY

LedsC4

2026

Content

| | |
|-----|-------------------------------|
| 006 | Summary |
| 020 | Universes |
| 022 | Services |
| 024 | Sustainability |
| 026 | Decorative |
| 374 | Fans |
| 414 | Smart lighting devices |

Index by Family

Attic



Suspensión
Suspensão

129



Superficie de pared
Superfície de parede

300

Bloom

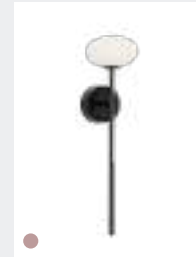

Superficie de pared
Superfície de parede

288

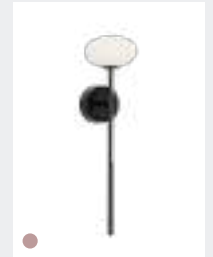

Baño
Casa de banho

360

Caprice



Suspensión
Suspensão

168



Superficie de techo
Superfície de teto

344

Circular



Suspensión
Suspensão

030



Superficie de pared
Superfície de parede

030

Clip



Lectura
Leitura

202



Sobremesa
De mesa

234



Pie
Pé

268

Gamma



Lectura
Leitura

192



Lectura
Leitura

194



Sobremesa
De mesa

228



Pie
Pé

264

Gong

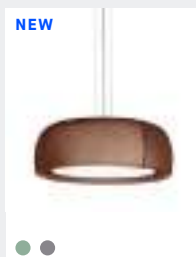

Suspensión
Suspensão

104



Superficie de techo
Superfície de teto

332

● Quick Service

● Performance Universe ● Essential Universe

Consulta la explicación completa en P. 034
Consulte a explicação completa na P. 034

Hop



Suspensión
Suspensão

046



Superficie de pared
Superfície de parede

046

H



Suspensión
Suspensão

140



Sobremesa
De mesa

216



Pie
Pé

258



Superficie de pared
Superfície de parede

306

Ilargi



Suspensión
Suspensão

092



Sobremesa
De mesa

218

Invisible



Suspensión
Suspensão

151



Lectura
Leitura

184



Sobremesa
De mesa

226



Pie
Pé

262

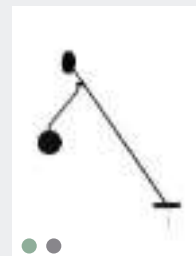

Superficie de pared
Superfície de parede

292

Levels



Suspensión
Suspensão

086



Sobremesa
De mesa

212



Pie
Pé

250



Superficie de techo
Superfície de teto

328

Metrica



Lectura
Leitura

204



Sobremesa
De mesa

236



Pie
Pé

270



Superficie de pared
Superfície de parede

313

Miso



Superficie de pared
Superficie de parede
309



Superficie de techo
Superficie de teto
346

Noway



Suspensión
Suspensão
124



Pie
Pé
256

Nude



Sobremesa
De mesa
231



Pie
Pé
265

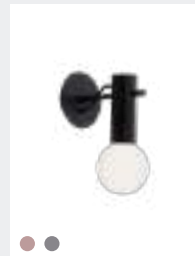

Superficie de pared
Superficie de parede
312

Organic



Sobremesa
De mesa
229



Pie
Pé
253



Superficie de pared
Superficie de parede
308

Perlina



Lectura
Leitura
182



Sobremesa
De mesa
220



Pie
Pé
254



Superficie de pared
Superficie de parede
276



Baño
Casa de banho
358

Pipe



Suspensión
Suspensão
170



Lectura
Leitura
196



Superficie de techo
Superficie de teto
354

Prolix



Suspensión
Suspensão
154



Superficie de pared
Superficie de parede
294



Superficie de techo
Superficie de teto
350

Simply



Lectura
Leitura

197



Sobremesa
De mesa

230



Superficie de techo
Superficie de teto

353

Spark



Superficie de pared
Superficie de parede

278

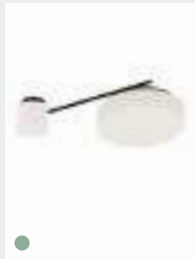

Superficie de techo
Superficie de teto

340

Stylus



Suspensión
Suspensão

172



Lectura
Leitura

198



Superficie de techo
Superficie de teto

355

Super Attic



Suspensión
Suspensão

136



Superficie de pared
Superficie de parede

304

Tubs



Sobremesa
De mesa

222



Pie
Pé

260



Superficie de pared
Superficie de parede

289

Tubs Modular



Suspensión
Suspensão

058



Superficie de pared
Superfície de parede

058

Veneto



Suspensión
Suspensão

120

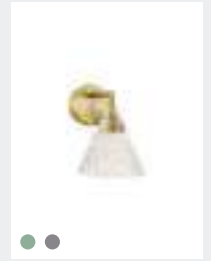

Superficie de pared
Superfície de parede

298

Vetro



Superficie de pared
Superfície de parede

311



Superficie de techo
Superfície de teto

349



Baño
Casa de banho

370

Index by Product

Decorative

Colecciones Modulares Coleções Modulares 028



Circular 030



Geometric 038



Hop 046



Scarlett 052



Tubs Modular 058

Suspensión Suspensão 076



Voiles 082



Levels 086



Ilargi 092



Iris 095



Plat 098



Khoi 100



Glam 102



Gong 104



Coco 112



Shoemaker 116



Veneto 120



Nimes 122



Noway 124



Keops 126



Attic 129



Super Attic 136



H 140



Napa 143



Candle 145



Invisible 151



Prolix 154



Dew 156



Alive 159



Punto 162



Mist 164



Circ 165



Caprice 168

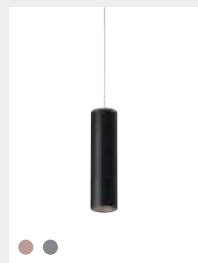

Pipe 170



Stylus 172



Bravo 174



Bol 177

Lectura
Leitura
178



Perlina 182



Invisible 184



Chic 186



E-lamp 188



E-lamp Mini 190



Hall Slim 191



Gamma 192

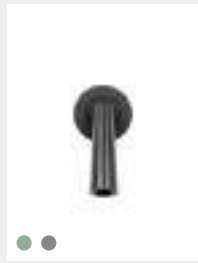

Gamma Mini 193



Gamma Extend 194



Radar 195



Pipe 196



Simply 197



Stylus 198



Bed 199

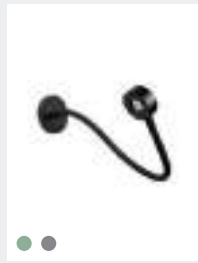

Link 200



Tip 201



Clip 202



Metrica 204

Sobremesa
De mesa
208



Dara 210



Levels 212



H 216



Ilargi 218



Perlina 220



Tubs 222



Maca 224



Invisible 226



Gamma 228



Organic 229



Simply 230



Nude 231



Clip 234



Metrica 236

Portátil
Portátil
238



Cocktail 240



Portobello 244

Pie
Pé
248



Levels 250



Organic 253



Perlina 254



Noway 256



H 258



Tubs 260



Invisible 262



Gamma 264



Nude 265



Clip 268



Metrica 270

Superficie
de pared
Superficie
de parede
272



Perlina 276



Spark 278



Trip 281



Trip Glass 286

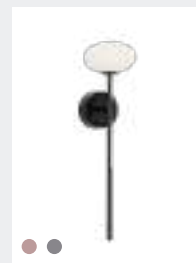

Bloom 288



Tubs 289

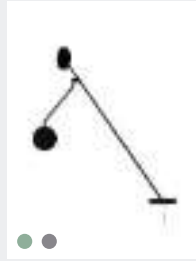

Invisible 292



Prolix 294



NEW
Linea 296

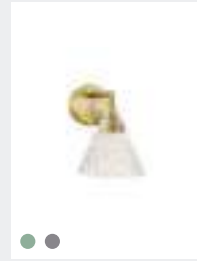

Veneto 298



Big Bang 299



Attic 300



Super Attic 304



H 306



Organic 308



Miso 309



Drone 310

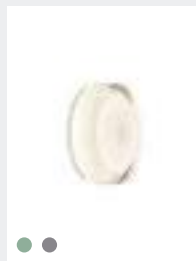

Vetro 311



Nude 312



Metrica 313



Fino 314



Duna 316



Lia 317



Lia LED 318



NEW
Mini 320



NEW
Mini Vertical 320



NEW
Mini Horizontal 320



NEW
Cut 322



Wilson 323



Ges 324

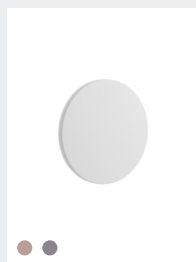

Ges Circular 325

Superficie de techo
Superficie de teto
326



Levels

328



Gong

332



Spark

340



Caprice

344



Miso

346



Bol

348



Vetro

349



Prolix

350



Simply

353



Pipe

354

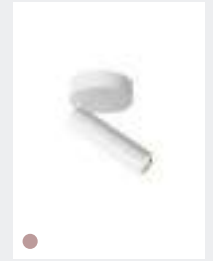

Stylus

355

Baño
Casa de banho
356



Perlina

358



Bloom

360



Dresde LED

362



Toi LED

364

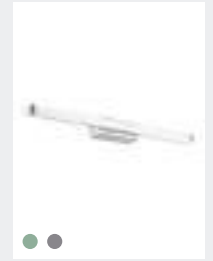

Toilet Slim

366



Mist

368



Vetro

370



Dec

371



Vanity

372

● Quick Service

● Performance Universe ● Essential Universe

Consulta la explicación completa en P. 034
Consulte a explicação completa na P. 034

Fans

Colección de ventilación Coleção de ventilação 374



Stem Evo
Without light 386



Stem Evo
With light 388



Stem Evo
With Play Super Comfort 390



Marinada 394



Bosc 396



Pam 398



Helix 400



Bora 402



Calar 404



Garbí 406



July 408



Shadow 410



Zonda 412

Smart lighting

**DALI2
418**



**Bluetooth
Casambi
422**



**DMX
426**



**Standalone
428**



Performance Universe



ES

Soluciones para proyectos con exigencias lumínicas y de diseño elevadas, donde la luz requiere un alto grado de adaptación a las condiciones del espacio.

Una propuesta basada en una amplia variedad de ópticas y potencias, opciones avanzadas de acabados y personalización, configuración técnica avanzada, flexibilidad en orientación y configuración.

PT

Soluções para projetos com exigências lumínicas e de design elevadas, onde a luz requer um alto grau de adaptação às condições do espaço.

Uma proposta baseada numa ampla variedade de óticas e potências, opções avançadas de acabamentos e personalização, configuração técnica avançada, flexibilidade na orientação e configuração.

Essential Universe

ES

Soluciones bien diseñadas, cuidadosamente desarrolladas, pensadas para proyectos con necesidades lumínicas claras y una configuración más directa.

Una propuesta basada en configuraciones claras y equilibradas, selección optimizada de ópticas y potencias, configuraciones definidas y eficientes, diseño cuidado y fiable.

PT

Soluções bem concebidas, cuidadosamente desenvolvidas, pensadas para projetos com necessidades lumínicas claras e uma configuração mais direta.

Uma proposta baseada em configurações claras e equilibradas, seleção otimizada de óticas e potências, configurações definidas e eficientes, conceção cuidada e fiável.



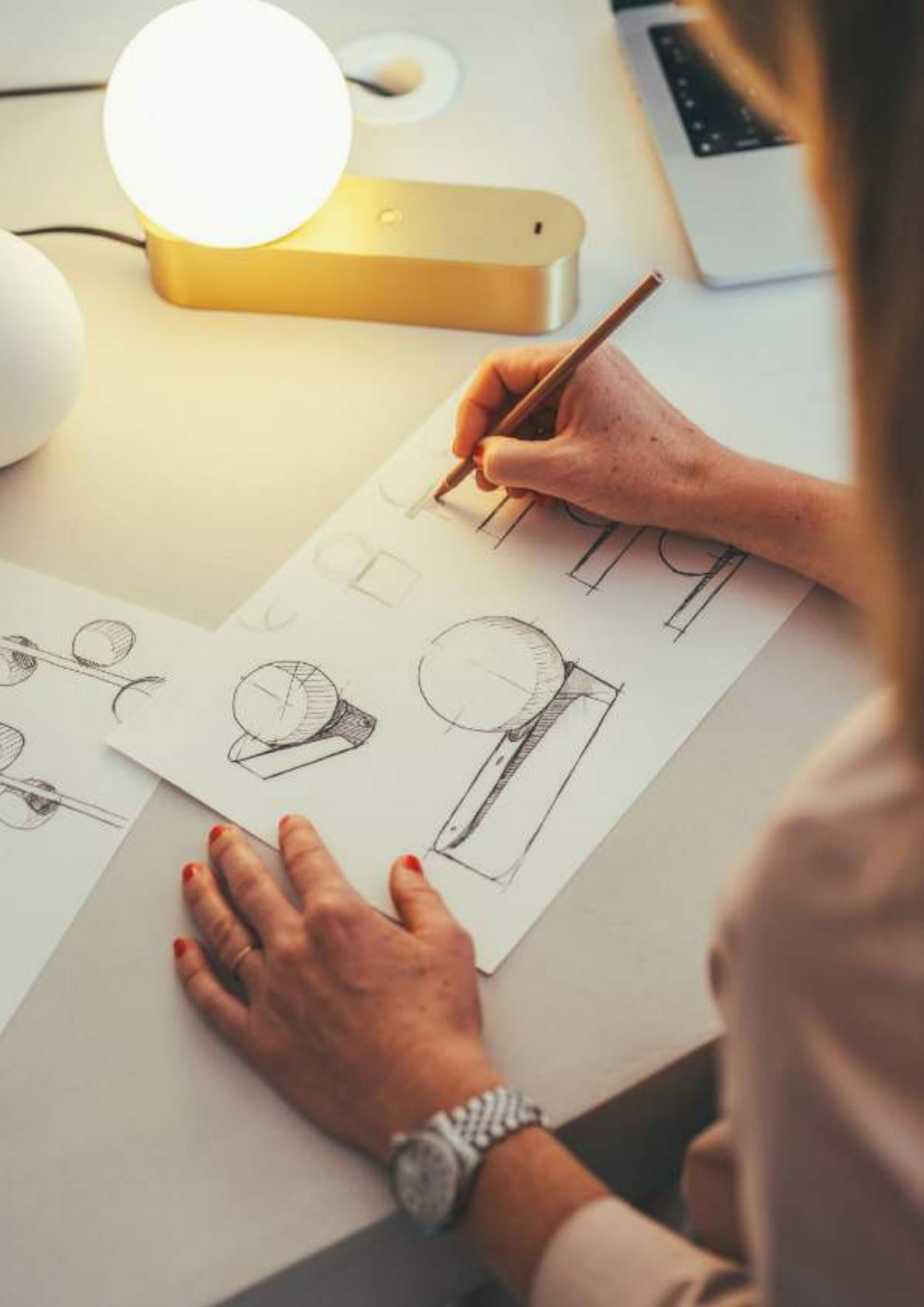

Servicios

Serviços

BESPOKE & CO-CREATION

Colaboramos estrechamente con nuestros clientes en el desarrollo de luminarias especiales a medida, así como en la adaptación de productos existentes. A partir de una necesidad concreta, trabajamos conjuntamente para crear soluciones lumínicas únicas, ajustando diseño, tecnología y prestaciones a los requisitos especiales de cada proyecto.

Trabalhamos em estreita colaboração com os nossos clientes no desenvolvimento de luminárias especiais à medida, assim como na adaptação de produtos existentes. A partir de uma necessidade concreta, trabalhamos em conjunto para criar soluções lumínicas únicas, ajustando o design, a tecnologia e o desempenho aos requisitos especiais de cada projeto.

TECHNICAL ADVISORY

Desarrollamos de forma integral su proyecto lumínico, desde la definición del concepto hasta la materialización final. Nuestro equipo de expertos trabaja sobre el espacio, el uso y la experiencia, aportando criterio lumínico, desarrollo técnico y soporte especializado en todas las fases, para ofrecer soluciones alineadas con los objetivos del proyecto.

Desenvolvemos de forma integral o seu projeto lumínico, desde a definição do conceito até à materialização final. A nossa equipa de especialistas trabalha em função do espaço, da utilização e da experiência, contribuindo com critérios lumínicos, desenvolvimento técnico e apoio especializado em todas as fases, para oferecer soluções alinhadas com os objetivos do projeto.

SMART LIGHTING

Acercamos la tecnología para que la iluminación inteligente forme parte natural de cada proyecto. Creamos entornos dinámicos y flexibles que mejoran la experiencia y el bienestar de las personas, incorporando la eficiencia, la sostenibilidad y el ahorro energético. Acompañamos al cliente desde la fase de conceptualización hasta la etapa posterior a la instalación, integrando y configurando sistemas de control y conectividad que permiten una gestión avanzada de la iluminación.

Aproximamos a tecnologia para que a iluminação inteligente se torne uma parte natural de cada projeto. Criamos ambientes dinâmicos e flexíveis que melhoram a experiência e o bem-estar das pessoas, incorporando eficiência, sustentabilidade e poupança energética. Acompanhamos o cliente desde a fase de conceção até à fase pós-instalação, integrando e configurando sistemas de controlo e conectividade que permitem uma gestão avançada da iluminação.

Sostenibilidad Sustentabilidade

ES

Entendemos la sostenibilidad como un compromiso global que abarca tanto a la empresa como a cada uno de nuestros productos. Trabajamos de forma constante para reducir la huella de carbono de la organización y garantizar una gestión responsable, respaldada por sistemas certificados según las normas ISO 9001 e ISO 14001. Diseñamos luminarias duraderas y eficientes, evaluando su impacto ambiental a lo largo de todo su ciclo de vida para seguir evolucionando y ofrecer soluciones de iluminación cada vez más responsables.

PT

Entendemos a sustentabilidade como um compromisso global que engloba tanto a empresa como cada um dos nossos produtos. Trabalhamos de forma constante para reduzir a pegada de carbono da organização e garantir uma gestão responsável, apoiada por sistemas certificados ISO 9001 e ISO 14001. Concebemos luminárias duradouras e eficientes, avaliando o seu impacto ambiental ao longo de todo o seu ciclo de vida para continuar a evoluir e a oferecer soluções de iluminação cada vez mais responsáveis.





Decorative

- 028** **Colecciones modulares**
Coleções modulares
- 076** **Suspensión**
Suspensão
- 178** **Lectura**
Leitura
- 208** **Sobremesa**
De mesa
- 238** **Portátil**
Portátil
- 248** **Pie**
Pé
- 272** **Superficie de pared**
Superfície de parede
- 326** **Superficie de techo**
Superfície de teto
- 356** **Baño**
Casa de banho

Colecciones Modulares

Coleções Modulares



Circular

030



Geometric

038



Hop

046



Scarlett

052



Tubs Modular

058

Circular



Performance Universe



La pureza del círculo

Circular es una pieza minimalista que juega con una la luz, haciendo posible que funcione como una luminaria ambiental o funcional debido a la amplitud de variaciones que permite.

Con una clara expresión contemporánea, apuesta por la versatilidad ofreciendo tres direcciones de luz, diferentes medidas y diversidad de composiciones, tanto vertical como horizontal, simple y chandelier.

A pureza do círculo

Circular é uma peça minimalista que joga com a luz, podendo funcionar como luminária ambiental ou funcional, devido ao vasto leque de variações que permite.

Com uma clara expressão contemporânea, aposta na versatilidade, oferecendo três direções de luz, diferentes medidas e uma diversidade de composições, tanto verticais como horizontais, simples e chandelier.







Con posibilidad de tres direcciones de luz: interior, exterior e inferior.

Com possibilidade de três direções de luz: interior, exterior e inferior.



Todos los modelos disponibles en tres acabados: blanco, negro y dorado. Difusor de silicona.

Todos os modelos disponíveis em três acabamentos: branco, preto e dourado. Difusor de silicone.

Configura tu Circular Horizontal

Configure a sua Circular Horizontal

| | | | | | | | | |
|----------|---|---------------------------------------|---|------------|--|-----------|---|--|
| C | F Dirección de la luz Direção da luz | 4 Instalación Instalação | G Combinaciones estandard Combinações standard | -00 | X9 Temperatura de la luz Temperatura da luz | AZ | DU Fuente de alimentación Fonte de alimentação | 05 Acabados Acabamentos |
| | S Downward D Inward F Outwar | 4 Surface 5 Recessed | A E K M B F L N C G P D H | | V9 2700K W9 3000K X9 4000K | | OU ON-OFF DU DALI RU 1-10V | 05 Black 14 White EF Gold |

1 Dirección de la luz

Direção da luz

* Dirección de luz inferior no aplicable a chandeliers con diferentes medidas de aro intercaladas, como F y E.

* A direção da luz inferior não é aplicável a lustres com diferentes medidas de aro intercaladas, como F e E.

S* Downward

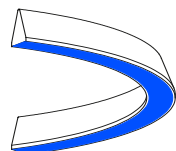

D Inward

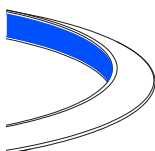

F Outward

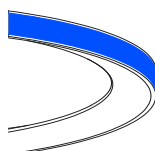

2 Instalación

Instalação

* No disponible para los chandelier
* No disponible para los chandelier

* Los aros Ø2000 (C) y Ø3000 (D) están equipados con 3 sirgas de tensión y 3 canopies como parte de su sistema de instalación.

* Los aros Ø2000 (C) y Ø3000 (D) están equipados con 3 sirgas de tensión y 3 canopies como parte de su sistema de instalación.

4 Surface

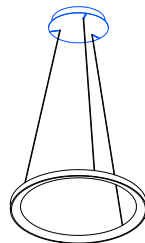

5* Recessed

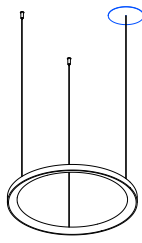

3 Medida de aro

Medida do aro

Ø600



Ø900



Ø1200



Ø2000



Ø3000



4 Temperatura de la luz

Temperatura da luz

V9 2700K



W9 3000K



X9 4000K



5 Fuentes de alimentación

Fonte de alimentação

OU ON/OFF
120-240V

DU DALI
100-240V

RU 1-10V
100-240V

6 Acabados

Acabamentos

05 Black



14 White



EF Gold



Combinaciones estandar

Combinações standard

Individual horizontal

Individual horizontal

Los W indicados en las combinaciones individuales horizontales hacen referencia a la dirección de la luz downward (S).
Os W indicados nas combinações horizontais individuais referem-se à direção da luz downward (S).

A Ø600 mm

Min. 500
Max. 3000

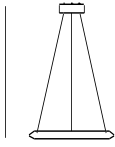

33 W
1924-3674 lm

K Ø900 mm

Min. 700
Max. 3000

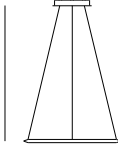

46 W
2081-4159 lm

B Ø1200 mm

Min. 700
Max. 3000

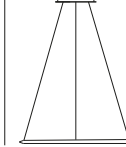

60 W
3345-6116 lm

C Ø2000 mm

Min. 800
Max. 5000

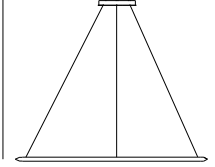

108 W
5827-10522 lm

D Ø3000 mm

Min. 800
Max. 5000

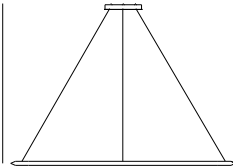

174 W
8473-15758 lm

P Ø2000+2000 mm

Min. 800
Max. 5000

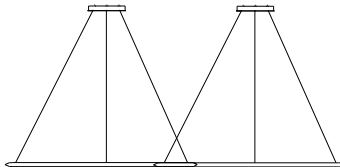

516 W
11654-21044 lm

Chandelier horizontal

Chandelier horizontal

Los W indicados en las combinaciones chandeliers horizontales hacen referencia a la dirección de la luz outward (F).
Os W indicados nas combinações de lustres horizontais referem-se à direção da luz outward (F).

M Ø1200+900 mm

Min. 1000
Max. 3000

Min. 1500
Max. 3000

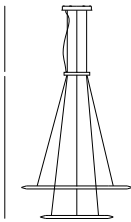

124 W
5628-9108 lm

N Ø900+600 mm

Min. 1000
Max. 3000

Min. 1500
Max. 3000

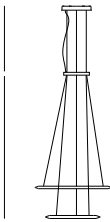

91 W
4005-6666 lm

L Ø1200+900+600 mm

Min. 1000
Max. 3000

Min. 1500
Max. 3000

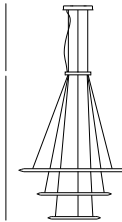

159 W
7635-12782 lm

G Ø3000+2000+1200 mm

Min. 1000
Max. 4000

Min. 1500
Max. 3000

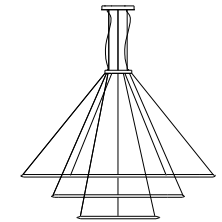

381 W
14858-32396 lm

H Ø2000+1200+600 mm

Min. 1000
Max. 3000

Min. 1500
Max. 3000

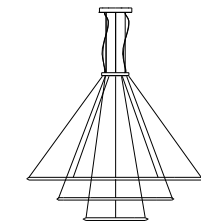

234 W
11179-20312 lm

F Ø600+1200+2000+ 1200+600 mm

Min. 1000
Max. 3000

Min. 1500
Max. 2500

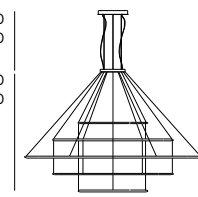

340 W
16531-30102 lm

E Ø1200+2000+3000+ 2000+1200 mm

Min. 1000
Max. 4000

Min. 2000
Max. 2500

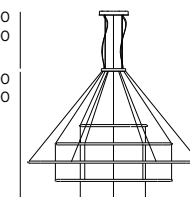

575 W
26817-49034 lm

Configura tu Circular Wall

Configure a sua Circular Wall

NEW

| | | | | | | | | |
|----------|--|---------------------------------------|---|------------|--|-----------|---|--------------------------------------|
| C | F Dirección de la luz Direção da luz | 4 Instalación Instalação | A Combinaciones estandard Combinações standard | -05 | V9 Temperatura de la luz Temperatura da luz | AZ | DU Fuente de alimentación Fonte de alimentação | 05 Acabados Acabamentos |
| | S Downward D Inward F Outward P Outward | 4 Surface 6 Recessed | A Ø600 mm K Ø900 mm | | V9 2700K W9 3000K | | DU DALI | 05 Black EF Gold |

1 Dirección de la luz

Direção da luz

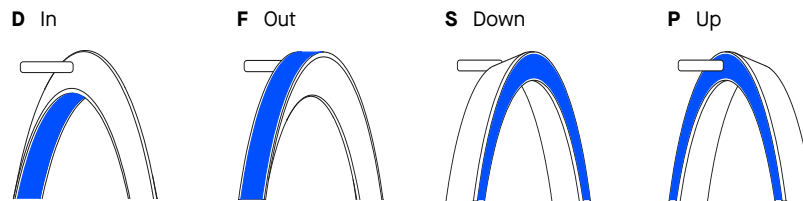

2 Instalación

Instalação

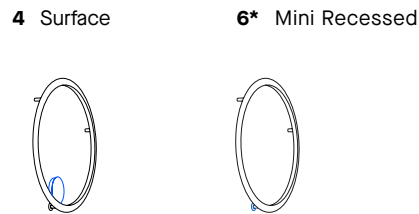

3 Medida de aro

Medida do aro

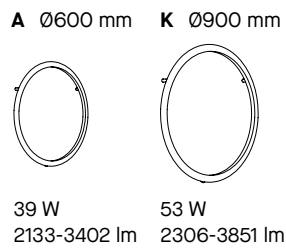

4 Temperatura de la luz

Temperatura da luz

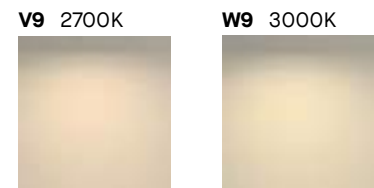

5 Fuentes de alimentación

Fonte de alimentação

DU DALI
100-240V

6 Acabados

Acabamentos

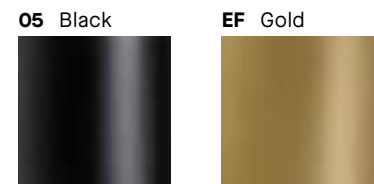

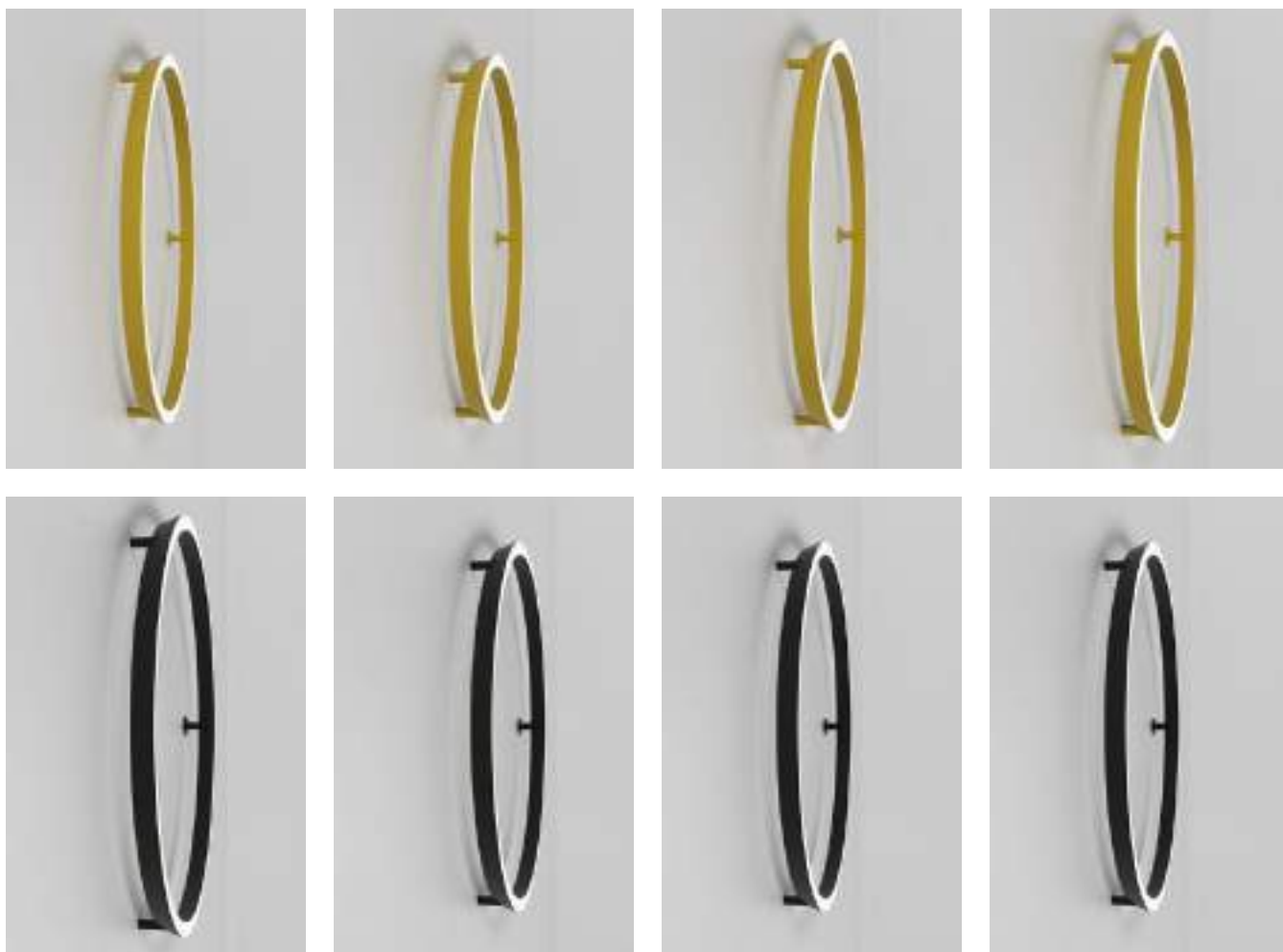

Con posibilidad de tres direcciones de luz: In, Out, Down y Up.
Com possibilidade de quatro direções de luz: In, Out, Down e Up.

Instalación Surface y Mini Recessed
Instalação Surface e Mini Recessed



Geometric



Performance Universe



Geometría modular

Sin geometría no entendemos la arquitectura y viceversa. Geometric es una colección modular de máximos, con capacidad para adaptar la luz a cualquier espacio. Gracias a las combinaciones de sus componentes, se pueden crear figuras que pueden adaptarse a cada proyecto, pudiendo dirigir y modelar la dirección de la luz.

Geometria modular

Sem geometria não entendemos a arquitetura e vice-versa. Geometric é uma coleção modular de máximos, com capacidade para adaptar a luz a qualquer espaço. Graças às combinações dos seus componentes, é possível criar figuras que podem ser adaptadas a cada projeto, podendo dirigir e moldar a direção da luz.



Configura tu Geometric

Configure a sua Geometric



Configurador para personalización disponible.
Configurador para personalização disponível.

geometric.ledsc4.com

| | | | | | | | | |
|--|---|---|---|------------|--|-----------|---|--|
| T Estructura Estrutura | S Dirección de la luz Direção da luz | 4 Instalación Instalação | Z Combinaciones estandard Combinações standard | -00 | X9 Temperatura de la luz Temperatura da luz | AZ | RU Fuente de alimentación Fonte de alimentação | 05 Acabados Acabamentos |
| T Triangle Q Square R Rectangle O Oval L Lineal | S Downward | 4 Surface 5 Recessed 6 Mini 7 Slim 8 Slim Recessed | S W X Y Z | | V9 2700K W9 3000K X9 4000K | | OS ON-OFF DS DALI DU DALI RU 1-10V | 05 Black 14 White EF Gold |

1 Estructura Estrutura

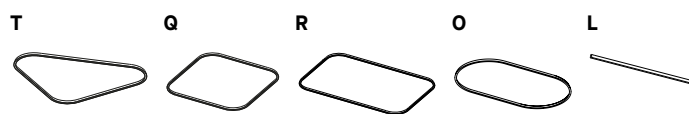

2 Dirección de la luz Direção da luz

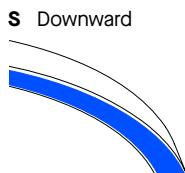

3 Instalación Instalação

*Para esta instalación es necesario el acceso posterior.
*O acesso traseiro é necessário para esta instalação.

** En combinaciones estandard solo disponibles para estructuras V, W y L y fuentes de alimentación OS y DS (para más opciones consultar en el configurador).

** Em combinações standard apenas disponíveis para estruturas V, W e L e fontes de alimentação OS e DS (para mais opções, ver configurador).

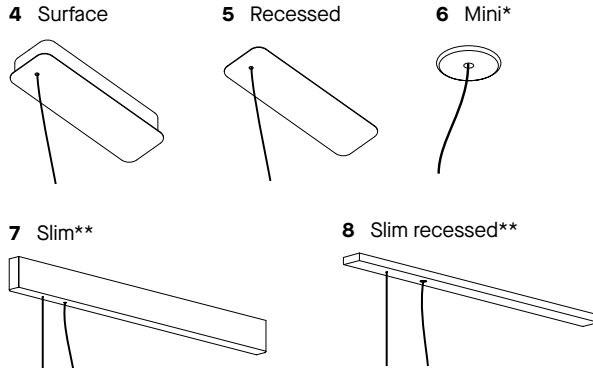

4 Temperatura de la luz Temperatura da luz



5 Fuentes de alimentación Fonte de alimentação

| | | | |
|------------------------------|----------------------------|----------------------------|-----------------------------|
| OS ON/OFF 220-240V | DS DALI 220-240V | DU DALI 100-240V | RU 1-10V 100-240V |
|------------------------------|----------------------------|----------------------------|-----------------------------|

6 Acabados Acabamentos



Combinaciones estandar
Combinações standard

TRIANGLES

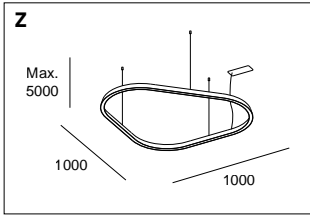

68 W
3394-4416 lm

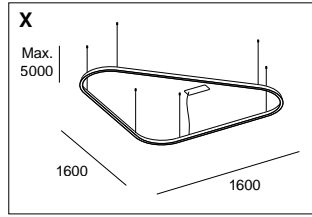

110 W
5638-7336 lm

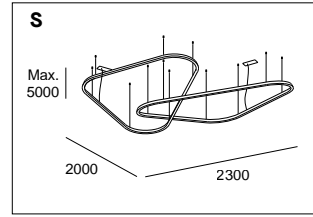

220 W
11276-14672 lm

LINEAL

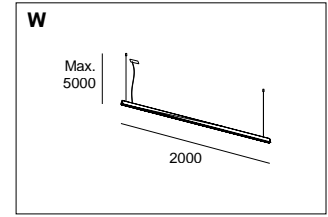

42 W
2189-2803 lm

SQUARES

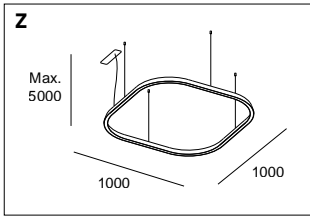

76 W
3825-4978 lm

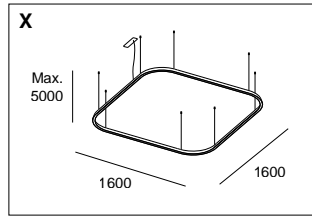

125 W
6455-8399 lm

RECTANGLES

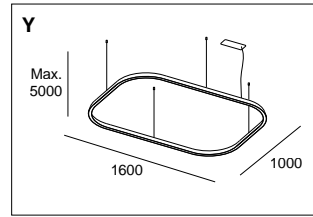

100 W
5140-6688 lm

OVAL

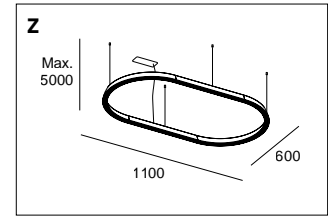

61 W
3174-4065 lm



Componentes Configurator

Componentes Configurator



Para crear figuras libres que se adapten a tu proyecto
 Para criar figuras livres que se adaptem ao seu projeto

Rectas

Retas

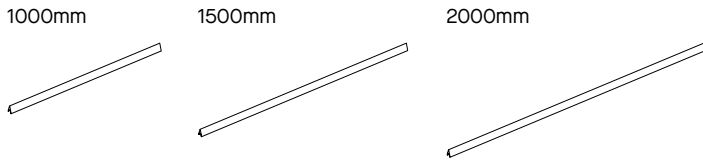

Curvas

Corbas

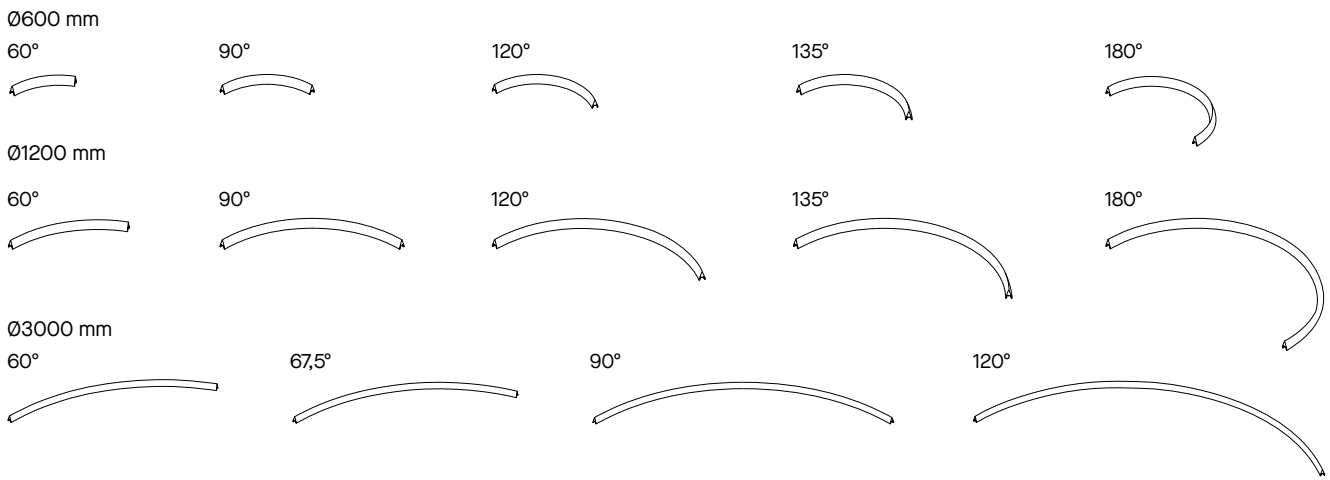

Cada perfil tiene opción:
 Cada perfil tem opção de:

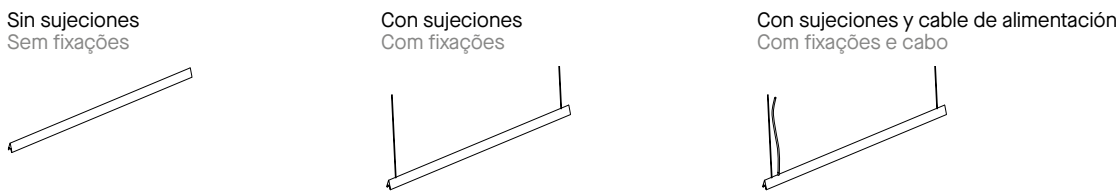

Posibles combinaciones

Posibles combinaciones

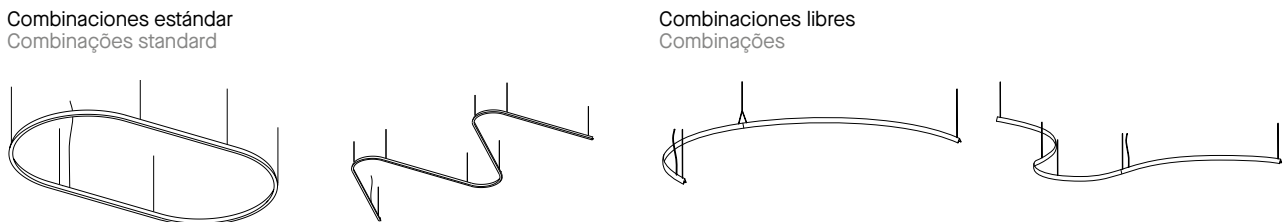

Florón

Florão

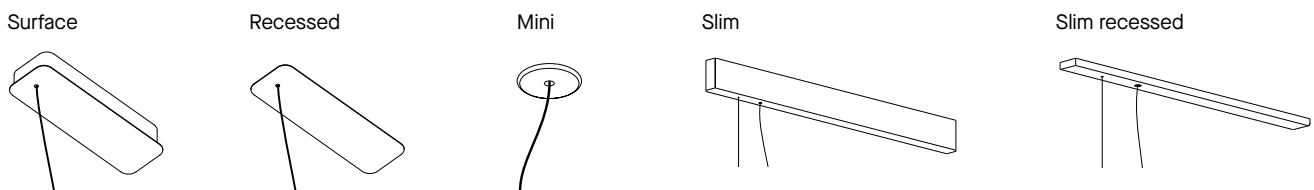





Múltiples combinaciones de estructuras, florones y acabados disponibles.

Múltiplas combinações de estruturas, florões e acabamentos disponíveis.



LS8W-00W9AZOS05



OS4Z-00W9AZOS14



TS4S-00W9AZOS14



QS5Z-00W9AZOS05



QS4X-00V9AZOU05



TS4X-00V9AZOU05

Hop NEW



Performance Universe



Chandelier contemporâneo modular que aporta dinamismo y ligereza visual.

Su versatilidad compositiva permite crear múltiples configuraciones, adaptándose a cualquier tipo de ambiente. Los elementos pueden colocarse cerca del techo o suspendidos a diferentes alturas, creando volumen, ritmo y movimiento según el espacio.

Hop combina libertad compositiva con simplicidad estructural, funcionando a partir de un único punto de conexión eléctrica, lo que permite distribuir los elementos de manera flexible.

Chandelier contemporâneo modular que confere dinamismo e leveza visual.

A sua versatilidade compositiva permite a criação de múltiplas configurações, adaptando-se a qualquer tipo de ambiente. Os elementos podem ser colocados junto ao teto ou suspensos a diferentes alturas, criando volume, ritmo e movimento de acordo com o espaço.

Hop combina liberdade de composição com simplicidade estrutural, funcionando a partir de um único ponto de ligação elétrica, o que permite a distribuição dos elementos de forma flexível.



Configura tu Hop

Configure a sua Hop

Configuración personalizable, pensada para integrarse con elegancia y originalidad a cualquier proyecto.
Configuração personalizável, concebida para se integrar com elegância e originalidade em qualquer projeto.

1 Elige una conexión/florón

Escolher uma ligação/florão

QS



Florón techo pequeño
Florão de teto pequeno
71-C254-05-05

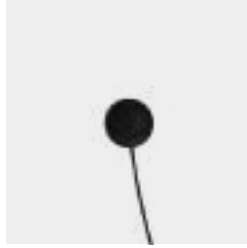

Florón pared pequeño
Florão de parede pequeno
71-C253-05-05

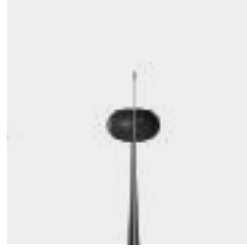

Florón 8 salidas de cable
Florão com 8 saídas de cabo
71-C262-05-05



Connexión con regulador
Ligação ao regulador
71-C265-05-05

2 Elige uno o más puntos de luz

Selecionar um ou mais pontos de luz

QS



Hop techo
Hop teto
71-C255-05-05



Hop colgante
Hop suspensa
71-C256-05-05



Hop techo suspendida
Hop teto suspensa
71-C255-05-05 +
71-C259-05-05



Hop aplique
Hop aplique
71-C257-05-05

Las versiones de techo y aplique permiten añadir uno o dos cables, ofreciendo mayor libertad compositiva.
As versões de teto e aplique permitem a adição de um ou dois fios, oferecendo uma maior liberdade de composição.

3 Elige el cableado

Escolher a cablagem

Cable disponible en varias longitudes, ajustable en obra para una adaptación total.
Cabo disponível em vários comprimentos, ajustável em obra para uma adaptação total.

QS



1.6m
71-C260-05-05



2.6m
71-C261-05-05



10m
71-C263-05-05



25m
71-C264-05-05

Cable disponible en otros colores bajo consulta.
Cabo disponível noutras cores, sob consulta.

4 Escoge tus accesorios necesarios

Escolher os acessórios necessários

QS

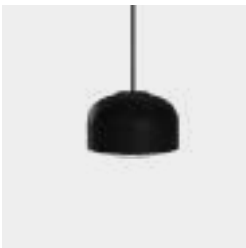

Pantalla metálica Hop
Tela metálica Hop
71-C258-05-14



Kit suspensión HOP techo suspendida
Kit de suspensão HOP teto falso
71-C259-05-05



Sus esferas de vidrio,
cuidadosamente elaboradas,
proporcionan una luz
envolvente y controlada.

As esferas de vidro
cuidadosamente trabalhadas
proporcionam uma luz
envolvente e controlada.



Hop reinventa el clásico
chandelier con un enfoque
contemporáneo.

Hop reinventa o clássico
chandelier com uma abordagem
contemporânea.

Combinaciones estandar
Combinações standard



Aplique Hop 1 luz
 Hop applique 1 luz
05-A109-05-37



Aplique Hop 2 luces
 Hop applique 2 luces
05-A110-05-37



Colgante Hop 1 luz
 Hop suspensa 1 luz
00-A372-05-37

2700K
 PHASE CUT

2700K
 PHASE CUT

2700K
 PHASE CUT



Colgante Hop 1 luz con pantalla
 Hop suspensa 1 luz com tela
00-A373-05-37



Colgante Hop 2 luces
 Hop suspensa 2 luces
00-A374-05-37



Colgante Hop 2 luces con pantalla
 Hop suspensa 2 luces com tela
00-A375-05-37

2700K
 PHASE CUT

2700K
 PHASE CUT

2700K
 PHASE CUT



Colgante Hop 4 luces
 Hop suspensa 4 luces
00-A376-05-37

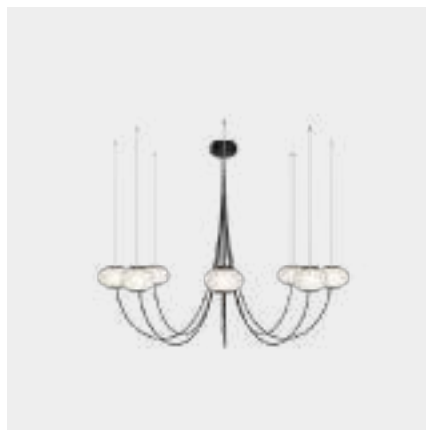

Colgante Hop 8 luces
 Hop suspensa 8 luces
00-A377-05-37



Colgante Hop 16 luces
 Hop suspensa 16 luces
00-A378-05-37

2700K
 PHASE CUT

2700K
 PHASE CUT

2700K
 PHASE CUT

Scarlett



Performance Universe



Lágrimas de plástico sostenible de origen recuperado.
Lágrimas de plástico sustentável de origem reciclada.

Protagonismo de la luz

Scarlett es la actualización de los chandeliers clásicos. Esta nueva colección juega de manera magistral con el color de sus lágrimas y las geometrías esenciales creando elegantes proyecciones de sombras y tonalidades. Además, tiene unas características lumínicas muy funcionales para la iluminación de techos de multitud de ambientes y también permite graduar la temperatura de color según se desee. El diseño se ha llevado a cabo haciendo uso de materiales sostenibles como uno de sus principales puntos fuertes.

Esta colección también puede personalizarse jugando con el tamaño de sus piezas y los diferentes colores disponibles a través del configurador.

Protagonismo da luz

Scarlett é a atualização dos chandeliers clássicos. Esta nova coleção combina de forma magistral com a cor das suas lágrimas e as geometrias essenciais, criando elegantes projeções de sombras e tons. Além disso, tem características lumínicas muito funcionais para iluminar tetos numa multiplicidade de ambientes e permite também regular a temperatura da cor conforme desejado. O design foi realizado com materiais sustentáveis como um dos seus principais pontos fortes.

Esta coleção também pode ser personalizada combinando com o tamanho das suas peças e com as diferentes cores disponíveis através do configurador.



Configura tu Scarlett

Configure a sua Scarlett



Configurador para personalización disponible.
Configurador para personalização disponível.

scarlett.ledsc4.com

| | | | | | | |
|----------|--------------------------------------|--------------------------------------|--|---|---|---|
| S | G | S | I | -A | A | A |
| | Figura Figura | Instalación Instalação | Construcción Construção | LEVEL 1 Medidas figura Medida figura | LEVEL 2 Medidas figura Medida figura | LEVEL 3 Medidas figura Medida figura |
| | C Circular Q Square | S Surface P Pendant | I Individual T Tower C Chandelier | A 530mm B 730mm C 930mm O None | A 530mm B 730mm C 930mm O None | A 530mm B 730mm C 930mm O None |

1 Figura Figura



2 Instalación Installation



3 Construcción Construction

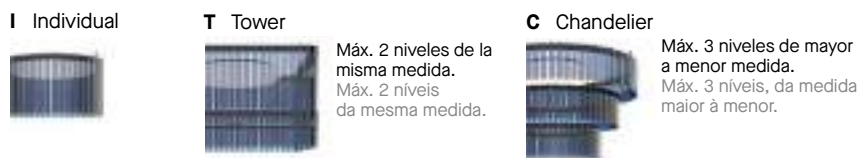

4 Medida figuras Medida figuras

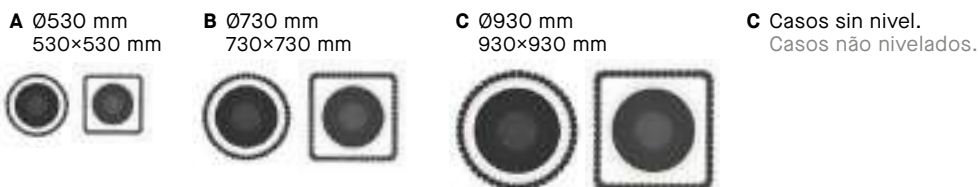

5 Medida lágrimas Medida lágrimas

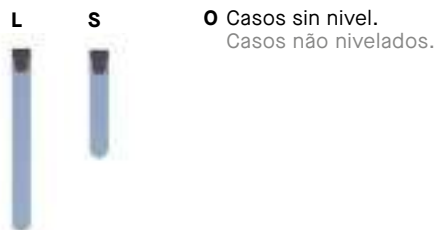

6 Acabados Acabamentos

Los acabados pueden sufrir cambios en función de múltiples factores.
Os acabamentos podem mudar em função de muitos fatores.

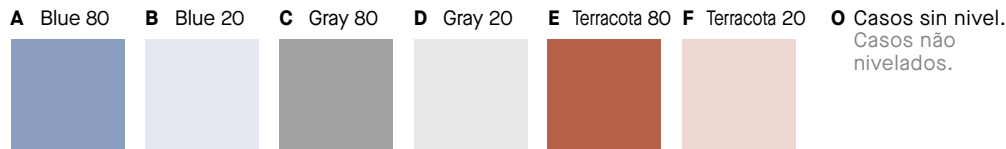

7 Fuente de alimentación Fonte de alimentação

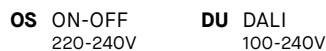

8 Temperatura de la luz Temperatura da luz

La pieza contiene un switch CCT.
A peça contém um interruptor CCT.

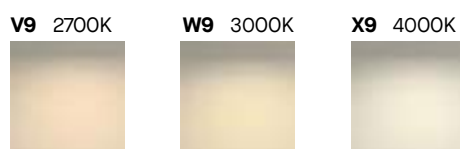

-SA

LEVEL 1
Medida/Acabado lágrima
Tamanho/Revestimento da lágrima

L 29cm A D O
S 17cm B E
O None C F

SA

LEVEL 2
Medida/Acabado lágrima
Tamanho/Revestimento da lágrima

L 29cm A D O
S 17cm B E
O None C F

SA

LEVEL 3
Medida/Acabado lágrima
Tamanho/Revestimento da lágrima

L 29cm A D O
S 17cm B E
O None C F

-DU

Fuente de alimentación
Fonte de alimentação

OS ON-OFF
DU DALI

V

Temperatura de la luz
Temperatura da luz

V 2700K
W 3000K
X 4000K

Combinaciones estandar
Combinações standard

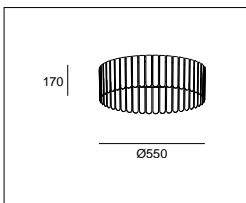

SCSI-A00-SC0000-OSV
SCPI-A00-SC0000-OSV

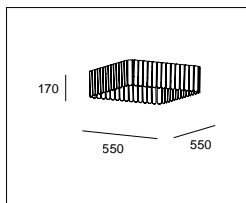

SGSI-A00-SF0000-OSV
SQPI-A00-SF0000-OSV

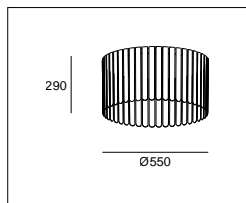

SCSI-A00-LD0000-OSV
SCPI-A00-LD0000-OSV

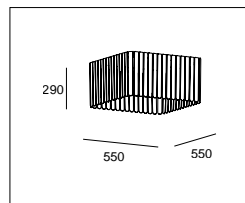

SGSI-A00-LA0000-OSV
SQPI-A00-LA0000-OSV

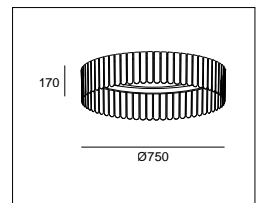

SCSI-B00-SE0000-OSV
SCPI-B00-SE0000-OSV

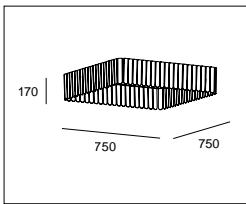

SGSI-B00-SB0000-OSV
SQPI-B00-SB0000-OSV

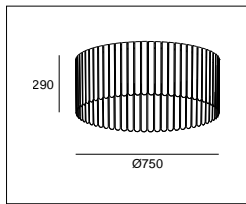

SCSI-B00-LF0000-OSV
SCPI-B00-LF0000-OSV

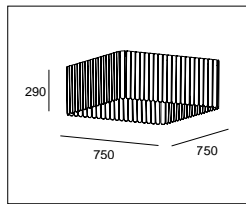

SGSI-B00-LE0000-OSV
SQPI-B00-LE0000-OSV

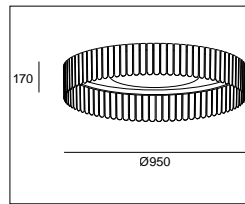

SCSI-C00-SA0000-OSV
SCPI-C00-SA0000-OSV

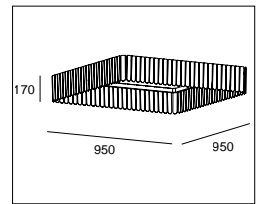

SGSI-C00-SD0000-OSV
SCPI-C00-SD0000-OSV

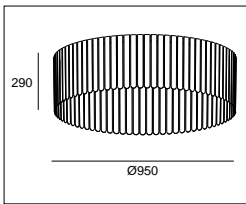

SCSI-C00-LB0000-OSV
SCPI-C00-LB0000-OSV

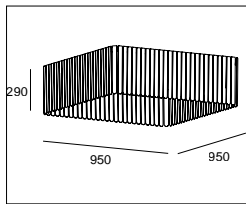

SGSI-C00-LC0000-OSV
SQPI-C00-LC0000-OSV

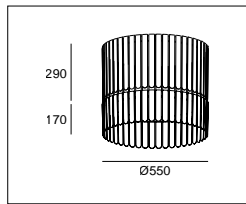

SCST-AA0-LCSD00-OSV
SQPT-AA0-LCSD00-OSV

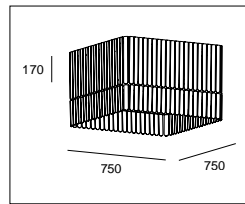

SGST-BB0-LASB00-OSV
SQPT-BB0-LASB00-OSV

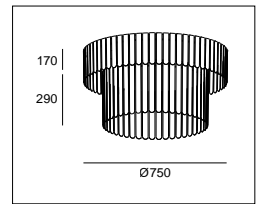

SCSC-BA0-SELFO0-OSV
SCPC-BA0-SELFO0-OSV

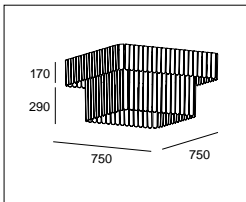

SQSC-BA0-SELFO0-OSV
SQPC-BA0-SELFO0-OSV

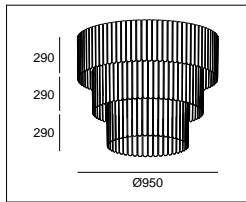

SCSC-CBA-LALALB-OSV
SCPC-CBA-LALALB-OSV

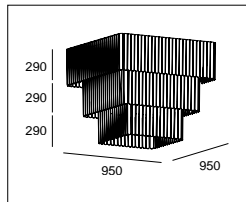

SQSC-CBA-LCLCLD-OSV
SQPC-CBA-LCLCLD-OSV

INFORMACIÓN COMÚN
INFORMAÇÃO COMUM

Surface structure 30mm
Pendant structure Max.

5000mm
3737-3907 lm
55 W

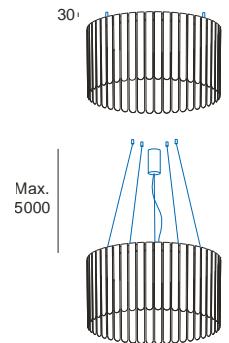



Distintas combinaciones y posibilidades de instalación.
Diferentes combinações e possibilidades de instalação.



SQPT-BBO-LCSD00-OSV



SCPC-CBO-LFLE00-OSV

Los acabados y tonalidad mostrados pueden no ser completamente precisos debido a ligeras variaciones en la producción, factores de iluminación, fotográficas e impresión.

Os acabamentos e tonalidades apresentados podem não ser totalmente precisos, devido a ligeiras variações na produção, fatores de iluminação fotográfica e de impressão.

Tubs Modular



Performance Universe



Tridimensionalidad orgánica

Tubs es un sistema de luz orgánico, capaz de llenar el espacio con una fuerte presencia lumínica o bien de ocupar el vacío con un agradable efecto ambiental. Su dinamismo se basa en esa dualidad, la de poder jugar con la posibilidad de dirigir fácilmente su halo de luz con un efecto directo o trabajar con una luz de reflejo. En todos los casos, su estructura modular es capaz de configurar al gusto su forma gracias a un amplio número de conectores y la gran facilidad con que se unen.

Tridimensionalidade orgânica

Tubs é um sistema de iluminação orgânico, capaz de preencher o espaço com uma forte presença lumínica ou ocupar o vazio com um agradável efeito ambiente. O seu dinamismo baseia-se nesta dualidade, a de poder jogar com a possibilidade de dirigir facilmente o seu feixe de luz com um efeito direto ou trabalhar com uma luz de reflexão. Em todos os casos, a sua estrutura modular é capaz de configurar a sua forma a gosto, graças a um grande número de conectores e à grande facilidade com que podem ser unidos.



Configura tu Tubs Modular

Configure a Tubs Modular

Configurador para personalización disponible.
Configurador para personalização disponível.

tubs.ledsc4.com

1 Instalación

Installation

Ceiling pendant

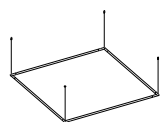

Ceiling/Wall surface

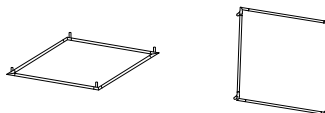

2 Florón

Florão

*Para esta instalación es necesario el acceso posterior.
*O acesso traseiro é necessário para esta instalação.

Ceiling

Surface

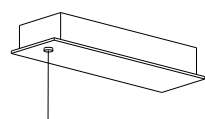

Recessed

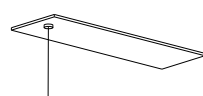

Recessed mini*



Wall

Potentiometer

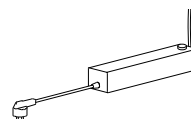

Recessed mini*



3 Componentes

Componentes

Tracks



50 mm
900 mm
1495 mm

Track connectors



Between levels
700 mm

Light Tubes



605 mm
900 mm
1200 mm
1495 mm

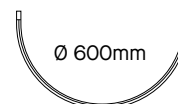

Light Tubes connectors



Initial/final



180°



90°

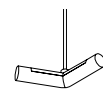

120°

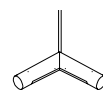

135°



Triple



Cuadruple

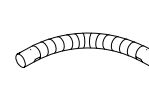

Flexo

Structure connectors



Wall attachment clip



Lights



Spot

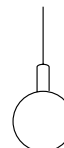

Sphere
Opal / Transparent

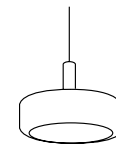

Disc
Opal / transparent

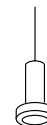

Pendant with
honeycomb

4 Temperatura de luz

Temperatura de luz

2700K



3000K



5 Fuente de alimentación

Fonte de alimentação

ON/OFF 105 W

DALI 105 W

ON/OFF 180 W

DALI 180 W

ON/OFF 320 W

DALI 320 W



Posibilidad de generar composiciones con distintos niveles de suspensión vertical.
Possibilidade de gerar composições com diferentes níveis de suspensão vertical.





Sistema de montaje rápido y sencillo.
Sistema de montagem rápido e fácil.



Tubs Modular cuenta con accesorios en diferentes acabados.
Tubs Modular possui acessórios em diversos acabamentos.

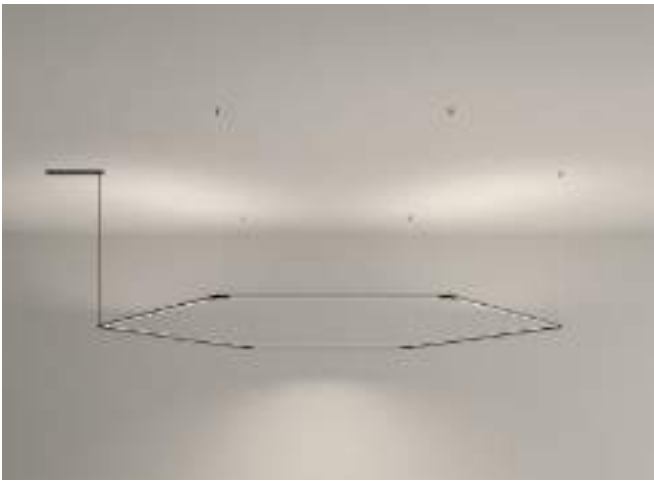

Instalación empotrada.
Instalação encastrada.

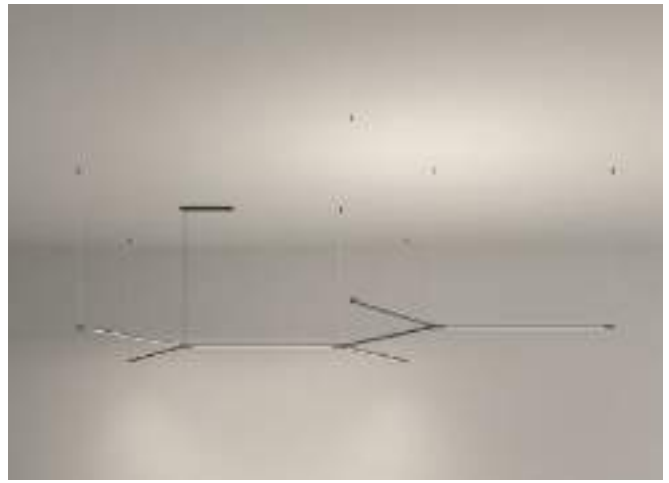

Instalación empotrada.
Instalação encastrada.



Instalación en superficie.
Instalação de superfície.



Instalación en superficie.
Instalação de superfície.



Instalación remota con florón mini.
Instalação remota com mini florão.



Instalación remota con florón mini.
Instalação remota com mini florão.

Estructuras colgantes con posibilidad de instalación en superficie o suspensión y con distintas opciones de florón.

Estruturas suspensas com possibilidade de instalação na superfície ou suspensa e com diferentes opções de florão.

Estructuras para pared con distintas opciones de instalación.
Estruturas para parede com diferentes opções de instalação.



Instalación remota con florón mini.
Instalação remota com mini florão.



Instalación con caja exterior y enchufe.
Instalação com caixa exterior e ficha.



Con los paneles de fieltro se pueden crear composiciones personalizables aportando características fonoabsorbentes a la instalación.
 Com os painéis de feltro, podem ser criadas composições personalizáveis, fornecendo características fonoabsorventes à instalação.

GA-GA ● GB-GB ●

No incluidos
 Não incluídos

| | Finishing | Code |
|------|-----------------------|-----------------------|
| | GA ● | 71-8498-GA-GA |
| | GB ● | 71-8498-GB-GB |
| | 01 ● | 71-8498-GP-01* |
| | 03 ● | 71-8498-GP-03* |
| | 05 ● | 71-8498-GP-05* |
| | 07 ● | 71-8498-GP-07* |
| | 12 ● | 71-8498-GP-12* |
| | 22 ● | 71-8498-GP-22* |
| 28 ● | 71-8498-GP-28* | |

| | Finishing | Code |
|------|-----------------------|-----------------------|
| | GA ● | 71-8497-GA-GA |
| | GB ● | 71-8497-GB-GB |
| | 01 ● | 71-8497-GP-01* |
| | 03 ● | 71-8497-GP-03* |
| | 05 ● | 71-8497-GP-05* |
| | 07 ● | 71-8497-GP-07* |
| | 12 ● | 71-8497-GP-12* |
| | 22 ● | 71-8497-GP-22* |
| 28 ● | 71-8497-GP-28* | |



Instalación con potenciómetro
Instalação com potenciômetro



Instalación remota con florón mini empotrado
Instalação remota com florão mini encastrada

Tubs Modular Wall Fixture

Tubs Modular Wall Fixture Lineal Simple

| | | | |
|----------|---------|--|------|
| BODY MAT | DIF MAT | | |
| AL | PMMA | | 360° |

Negro Preto 05 ●
Blanco opal Blanco opalino M1 ○

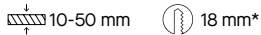
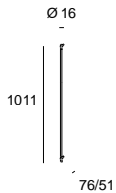

*Solo para instalación remota.
Somente para instalação remota.

LED | CRI 92 | W Total 13.1

| | | K | Real Lm | Structure | Difussor | Code |
|--|-----------------|------|---------|-----------|----------|-------------------------|
| | PWM 100-240V | 2700 | 1090 | 05 ● | M1 ○ | 05-A035-05-M1 |
| | ON-OFF 100-240V | 2700 | 1090 | 05 ● | M1 ○ | 05-A036-05-M1 |
| | DALI 100-240V | 2700 | 1090 | 05 ● | M1 ○ | 05-A037-05-M1 |
| | PWM 100-240V | 3000 | 1253 | 05 ● | M1 ○ | 05-8249-05-M1 |
| | ON-OFF 100-240V | 3000 | 1253 | 05 ● | M1 ○ | 05-A015-05-M1 QS |
| | DALI 100-240V | 3000 | 1253 | 05 ● | M1 ○ | 05-A022-05-M1 |

Tubs Modular Wall Fixture Lineal Double

| | | | |
|----------|---------|--|------|
| BODY MAT | DIF MAT | | |
| AL | PMMA | | 360° |

Negro Preto 05 ●
Blanco opal Blanco opalino M1 ○

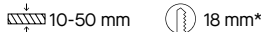
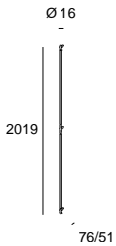

*Solo para instalación remota.
Somente para instalação remota.

LED | CRI 92 | W Total 26.2

| | | K | Real Lm | Structure | Difussor | Code |
|--|-----------------|------|---------|-----------|----------|-------------------------|
| | PWM 100-240V | 2700 | 2180 | 05 ● | M1 ○ | 05-A038-05-M1 |
| | ON-OFF 100-240V | 2700 | 2180 | 05 ● | M1 ○ | 05-A039-05-M1 QS |
| | DALI 100-240V | 2700 | 2180 | 05 ● | M1 ○ | 05-A040-05-M1 |
| | PWM 100-240V | 3000 | 2506 | 05 ● | M1 ○ | 05-8250-05-M1 |
| | ON-OFF 100-240V | 3000 | 2506 | 05 ● | M1 ○ | 05-A016-05-M1 QS |
| | DALI 100-240V | 3000 | 2506 | 05 ● | M1 ○ | 05-A023-05-M1 |

Tubs Modular Wall Fixture Square

| | | | |
|----------|---------|--|------|
| BODY MAT | DIF MAT | | |
| AL | PMMA | | 360° |

Negro Preto 05 ●
Blanco opal Blanco opalino M1 ○

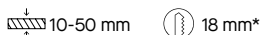
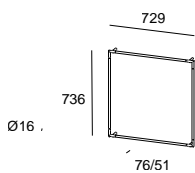



*Solo para instalación remota.
Somente para instalação remota.

LED | CRI 92 | W Total 35.2

| | | K | Real Lm | Structure | Difussor | Code |
|--|-----------------|------|---------|-----------|----------|-------------------------|
| | PWM 100-240V | 2700 | 2904 | 05 ● | M1 ○ | 05-A029-05-M1 |
| | ON-OFF 100-240V | 2700 | 2904 | 05 ● | M1 ○ | 05-A030-05-M1 QS |
| | DALI 100-240V | 2700 | 2904 | 05 ● | M1 ○ | 05-A031-05-M1 |
| | PWM 100-240V | 3000 | 3340 | 05 ● | M1 ○ | 05-8255-05-M1 |
| | ON-OFF 100-240V | 3000 | 3340 | 05 ● | M1 ○ | 05-A013-05-M1 QS |
| | DALI 100-240V | 3000 | 3340 | 05 ● | M1 ○ | 05-A020-05-M1 |

Tubs Modular Wall Fixture Combination

| | | | |
|----------|---------|---|---|
| BODY MAT | DIF MAT |  |  |
| AL | PMMA | 360° | 360° |



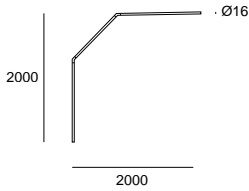



Negro Preto 05 ●
Blanco opal Branco opalino M1 ○





10-50 mm 18 mm*

*Solo para instalación remota.
Somente para instalação remota.

LED | CRI 92 | W Total 48.1

| | K | Real Lm | Structure | Difussor | Code |
|---|------|---------|-----------|----------|-------------------------|
|  PWM 100-240V | 2700 | 3996 | 05 ● | M1 ○ | 05-A041-05-M1 |
|  ON-OFF 100-240V | 2700 | 3996 | 05 ● | M1 ○ | 05-A042-05-M1 QS |
|  DALI 100-240V | 2700 | 3996 | 05 ● | M1 ○ | 05-A043-05-M1 |
|  PWM 100-240V | 3000 | 4593 | 05 ● | M1 ○ | 05-A017-05-M1 |
|  ON-OFF 100-240V | 3000 | 4593 | 05 ● | M1 ○ | 05-A018-05-M1 QS |
|  DALI 100-240V | 3000 | 4593 | 05 ● | M1 ○ | 05-A019-05-M1 |

Tubs Modular Wall Fixture Molecular

| | | | |
|----------|---------|---|---|
| BODY MAT | DIF MAT |  |  |
| AL | PMMA | 360° | 360° |



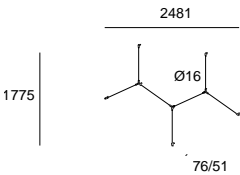



Negro Preto 05 ●
Blanco opal Branco opalino M1 ○





10-50 mm 18 mm*

*Solo para instalación remota.
Somente para instalação remota.

LED | CRI 92 | W Total 61.6

| | K | Real Lm | Structure | Difussor | Code |
|---|------|---------|-----------|----------|-------------------------|
|  PWM 100-240V | 2700 | 5082 | 05 ● | M1 ○ | 05-A032-05-M1 |
|  ON-OFF 100-240V | 2700 | 5082 | 05 ● | M1 ○ | 05-A033-05-M1 QS |
|  DALI 100-240V | 2700 | 5082 | 05 ● | M1 ○ | 05-A034-05-M1 |
|  PWM 100-240V | 3000 | 5845 | 05 ● | M1 ○ | 05-8279-05-M1 |
|  ON-OFF 100-240V | 3000 | 5845 | 05 ● | M1 ○ | 05-A014-05-M1 QS |
|  DALI 100-240V | 3000 | 5845 | 05 ● | M1 ○ | 05-A021-05-M1 |

Tubs Modular Wall Fixture Reticle

| | | | |
|----------|---------|---|---|
| BODY MAT | DIF MAT |  |  |
| AL | PMMA | 360° | 360° |



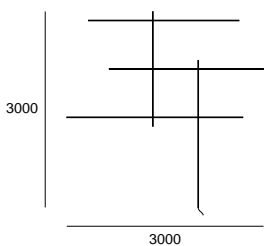

Negro Preto 05 ●
Blanco opal Branco opalino M1 ○



10-50 mm 18 mm*

*Solo para instalación remota.
Somente para instalação remota.

LED | CRI 92 | W Total 140.3

| | K | Real Lm | Structure | Difussor | Code |
|---|------|---------|-----------|----------|-------------------------|
|  ON-OFF 100-240V | 2700 | 11621 | 05 ● | M1 ○ | 05-A044-05-M1 QS |
|  DALI 100-240V | 2700 | 11621 | 05 ● | M1 ○ | 05-A045-05-M1 |
|  ON-OFF 100-240V | 3000 | 13361 | 05 ● | M1 ○ | 05-A024-05-M1 QS |
|  DALI 100-240V | 3000 | 13361 | 05 ● | M1 ○ | 05-A025-05-M1 |



Florón superficie
Florão superfície



Florón empotrado
Florão encastrado



Instalación remota con florón mini empotrado
Instalação remota com florão mini encastrada

Tubs Modular Pendant

Tubs Modular Pendant Single 600mm

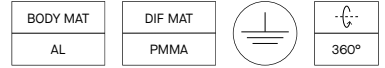

Negro Preto 05 ●
Blanco opal Branco opalino M1 ○

LED | CRI 92 | W Total 8.8

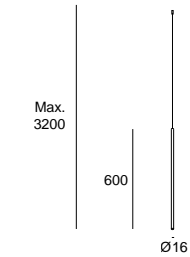

10-50 mm

87 × 244 mm (00-A176/00-A088)
84 × 314 mm (00-A177/00-A089)

18 mm

| | | K | Real Lm | Structure | Difussor | Code |
|--|-----------------|------|---------|-----------|----------|-------------------------|
| | ON-OFF 220-240V | 2700 | 726 | 05 ● | M1 ○ | 00-A176-05-M1 QS |
| | DALI 100-240V | 2700 | 726 | 05 ● | M1 ○ | 00-A177-05-M1 |
| | ON-OFF 100-240V | 2700 | 726 | 05 ● | M1 ○ | 00-A178-05-M1 QS |
| | DALI 100-240V | 2700 | 726 | 05 ● | M1 ○ | 00-A179-05-M1 |
| | ON-OFF 220-240V | 3000 | 835 | 05 ● | M1 ○ | 00-A088-05-M1 QS |
| | DALI 100-240V | 3000 | 835 | 05 ● | M1 ○ | 00-A089-05-M1 |
| | ON-OFF 100-240V | 3000 | 835 | 05 ● | M1 ○ | 00-A090-05-M1 QS |
| | DALI 100-240V | 3000 | 835 | 05 ● | M1 ○ | 00-A091-05-M1 |

Tubs Modular Pendant Single 900mm

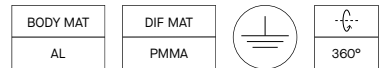

Negro Preto 05 ●
Blanco opal Branco opalino M1 ○

LED | CRI 92 | W Total 13.1

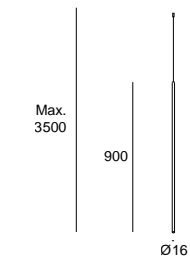

10-50 mm

87 × 244 mm (00-A180/00-A092)
108 × 314 mm (00-A181/00-A093)

18 mm

| | | K | Real Lm | Structure | Difussor | Code |
|--|-----------------|------|---------|-----------|----------|-------------------------|
| | ON-OFF 220-240V | 2700 | 1090 | 05 ● | M1 ○ | 00-A180-05-M1 QS |
| | DALI 100-240V | 2700 | 1090 | 05 ● | M1 ○ | 00-A181-05-M1 |
| | ON-OFF 100-240V | 2700 | 1090 | 05 ● | M1 ○ | 00-A182-05-M1 QS |
| | DALI 100-240V | 2700 | 1090 | 05 ● | M1 ○ | 00-A183-05-M1 |
| | ON-OFF 220-240V | 3000 | 1253 | 05 ● | M1 ○ | 00-A092-05-M1 QS |
| | DALI 100-240V | 3000 | 1253 | 05 ● | M1 ○ | 00-A093-05-M1 |
| | ON-OFF 100-240V | 3000 | 1253 | 05 ● | M1 ○ | 00-A094-05-M1 QS |
| | DALI 100-240V | 3000 | 1253 | 05 ● | M1 ○ | 00-A095-05-M1 |

Tubs Modular Pendant Lineal Double

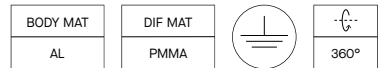

Negro Preto 05 ●
Blanco opal Branco opalino M1 ○

LED | CRI 92 | W Total 17.6

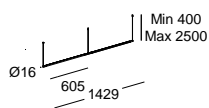

10-50 mm

84 × 314 mm (00-A134/00-8248)
87 × 244 mm (00-A138/00-8292)

18 mm

| | | K | Real Lm | Structure | Difussor | Code |
|--|-----------------|------|---------|-----------|----------|-------------------------|
| | ON-OFF 220-240V | 2700 | 1452 | 05 ● | M1 ○ | 00-A138-05-M1 QS |
| | DALI 100-240V | 2700 | 1452 | 05 ● | M1 ○ | 00-A134-05-M1 |
| | ON-OFF 100-240V | 2700 | 1452 | 05 ● | M1 ○ | 00-A139-05-M1 QS |
| | DALI 100-240V | 2700 | 1452 | 05 ● | M1 ○ | 00-A135-05-M1 |
| | ON-OFF 220-240V | 3000 | 1670 | 05 ● | M1 ○ | 00-8292-05-M1 QS |
| | DALI 100-240V | 3000 | 1670 | 05 ● | M1 ○ | 00-8248-05-M1 |
| | ON-OFF 100-240V | 3000 | 1670 | 05 ● | M1 ○ | 00-A060-05-M1 QS |
| | DALI 100-240V | 3000 | 1670 | 05 ● | M1 ○ | 00-A058-05-M1 |

Tubs Modular Pendant Rectangular Horizontal

| | | | |
|----------|---------|--|------|
| BODY MAT | DIF MAT | | |
| AL | PMMA | | 360° |

LED | CRI 92 | W Total 61.4

Negro Preto 05 ●
Blanco opal Branco opalino M1 ○

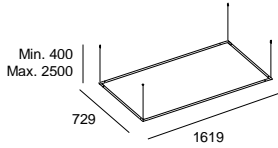

10-50 mm

84 × 314 mm (00-A128/00-8261)
87 × 244 mm (00-A140/00-8296)

18 mm

| | | K | Real Lm | Structure | Difusor | Code |
|--|-----------------|------|---------|-----------|---------|-------------------------|
| | ON-OFF 220-240V | 2700 | 5084 | 05 ● | M1 ○ | 00-A140-05-M1 QS |
| | DALI 100-240V | 2700 | 5084 | 05 ● | M1 ○ | 00-A128-05-M1 |
| | ON-OFF 100-240V | 2700 | 5084 | 05 ● | M1 ○ | 00-A141-05-M1 QS |
| | DALI 100-240V | 2700 | 5084 | 05 ● | M1 ○ | 00-A129-05-M1 |
| | ON-OFF 220-240V | 3000 | 5846 | 05 ● | M1 ○ | 00-8296-05-M1 QS |
| | DALI 100-240V | 3000 | 5846 | 05 ● | M1 ○ | 00-8261-05-M1 |
| | ON-OFF 100-240V | 3000 | 5846 | 05 ● | M1 ○ | 00-A061-05-M1 QS |
| | DALI 100-240V | 3000 | 5846 | 05 ● | M1 ○ | 00-A055-05-M1 |

Tubs Modular Pendant Rectangular Vertical

| | | | |
|----------|---------|--|------|
| BODY MAT | DIF MAT | | |
| AL | PMMA | | 360° |

LED | CRI 92 | W Total 61.4

Negro Preto 05 ●
Blanco opal Branco opalino M1 ○

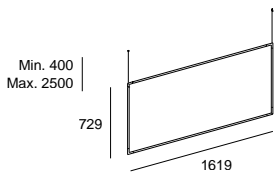

10-50 mm

84 × 314 mm (00-A126/00-8271)
87 × 244 mm (00-A142/00-8299)

18 mm

| | | K | Real Lm | Structure | Difusor | Code |
|--|-----------------|------|---------|-----------|---------|-------------------------|
| | ON-OFF 220-240V | 2700 | 5084 | 05 ● | M1 ○ | 00-A142-05-M1 QS |
| | DALI 100-240V | 2700 | 5084 | 05 ● | M1 ○ | 00-A126-05-M1 |
| | ON-OFF 100-240V | 2700 | 5084 | 05 ● | M1 ○ | 00-A143-05-M1 QS |
| | DALI 100-240V | 2700 | 5084 | 05 ● | M1 ○ | 00-A127-05-M1 |
| | ON-OFF 220-240V | 3000 | 5846 | 05 ● | M1 ○ | 00-8299-05-M1 QS |
| | DALI 100-240V | 3000 | 5846 | 05 ● | M1 ○ | 00-8271-05-M1 |
| | ON-OFF 100-240V | 3000 | 5846 | 05 ● | M1 ○ | 00-A062-05-M1 QS |
| | DALI 100-240V | 3000 | 5846 | 05 ● | M1 ○ | 00-A054-05-M1 |

Tubs Modular Pendant Double Arch

| | | | |
|----------|---------|--|------|
| BODY MAT | DIF MAT | | |
| AL | PMMA | | 360° |

LED | CRI 92 | W Total 71.2

Negro Preto 05 ●
Blanco opal Branco opalino M1 ○

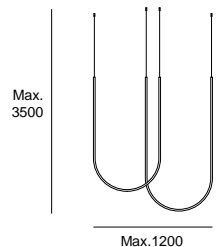

10-50 mm

87 × 244 mm (00-A154/00-A072)
108 × 314 mm (00-A155/00-A073)

18 mm

| | | K | Real Lm | Structure | Difusor | Code |
|--|-----------------|------|---------|-----------|---------|-------------------------|
| | ON-OFF 220-240V | 2700 | 5906 | 05 ● | M1 ○ | 00-A154-05-M1 QS |
| | DALI 100-240V | 2700 | 5906 | 05 ● | M1 ○ | 00-A155-05-M1 QS |
| | ON-OFF 100-240V | 2700 | 5906 | 05 ● | M1 ○ | 00-A156-05-M1 QS |
| | DALI 100-240V | 2700 | 5906 | 05 ● | M1 ○ | 00-A157-05-M1 QS |
| | ON-OFF 220-240V | 3000 | 6792 | 05 ● | M1 ○ | 00-A072-05-M1 QS |
| | DALI 100-240V | 3000 | 6792 | 05 ● | M1 ○ | 00-A073-05-M1 QS |
| | ON-OFF 100-240V | 3000 | 6792 | 05 ● | M1 ○ | 00-A074-05-M1 QS |
| | DALI 100-240V | 3000 | 6792 | 05 ● | M1 ○ | 00-A075-05-M1 QS |

*Limitación solo para instalación con florón Mini Recessed.
*Limitado apenas para instalação com florão Mini Recessed.

Tubs Modular Pendant Triplex Arch Cross

| | | |
|----------|---------|--|
| BODY MAT | DIF MAT | |
| AL | PMMA | |

Negro Preto 05 ●
Blanco opal Branco opalino M1 ○

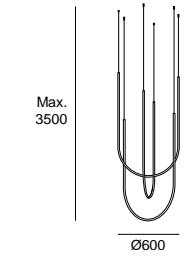

10-50 mm

87 × 244 mm (00-A158/00-A076)
108 × 314 mm (00-A159/00-A077)

18 mm

LED | CRI 92 | W Total 119.7

| | K | Real Lm | Structure | Difusor | Code |
|--|----------------------|---------|-----------|---------|-------------------------|
| | | | | | |
| | ON-OFF 220-240V 2700 | 9951 | 05 ● | M1 ○ | 00-A158-05-M1 QS |
| | DALI 100-240V 2700 | 9951 | 05 ● | M1 ○ | 00-A159-05-M1 QS |
| | ON-OFF 100-240V 2700 | 9951 | 05 ● | M1 ○ | 00-A166-05-M1 QS |
| | DALI 100-240V 2700 | 9951 | 05 ● | M1 ○ | 00-A167-05-M1 QS |
| | ON-OFF 220-240V 3000 | 11442 | 05 ● | M1 ○ | 00-A076-05-M1 QS |
| | DALI 100-240V 3000 | 11442 | 05 ● | M1 ○ | 00-A077-05-M1 QS |
| | ON-OFF 100-240V 3000 | 11442 | 05 ● | M1 ○ | 00-A078-05-M1 QS |
| | DALI 100-240V 3000 | 11442 | 05 ● | M1 ○ | 00-A079-05-M1 QS |

Tubs Modular Pendant Lineal Single with Arch

| | | |
|----------|---------|--|
| BODY MAT | DIF MAT | |
| AL | PMMA | |

Negro Preto 05 ●
Blanco opal Branco opalino M1 ○

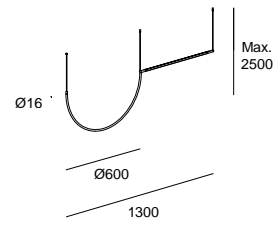

10-50 mm

87 × 244 mm (00-A146/00-A064)
108 × 314 mm (00-A147/00-A065)

18 mm

LED | CRI 92 | W Total 26.8

| | K | Real Lm | Structure | Difusor | Code |
|--|----------------------|---------|-----------|---------|-------------------------|
| | | | | | |
| | ON-OFF 220-240V 2700 | 1863 | 05 ● | M1 ○ | 00-A146-05-M1 QS |
| | DALI 100-240V 2700 | 2227 | 05 ● | M1 ○ | 00-A147-05-M1 |
| | ON-OFF 100-240V 2700 | 1863 | 05 ● | M1 ○ | 00-A148-05-M1 QS |
| | DALI 100-240V 2700 | 2227 | 05 ● | M1 ○ | 00-A149-05-M1 QS |
| | ON-OFF 220-240V 3000 | 2561 | 05 ● | M1 ○ | 00-A064-05-M1 QS |
| | DALI 100-240V 3000 | 2561 | 05 ● | M1 ○ | 00-A065-05-M1 QS |
| | ON-OFF 100-240V 3000 | 2143 | 05 ● | M1 ○ | 00-A066-05-M1 QS |
| | DALI 100-240V 3000 | 2561 | 05 ● | M1 ○ | 00-A067-05-M1 QS |

Tubs Modular Pendant Lineal Double with Arch

| | | |
|----------|---------|--|
| BODY MAT | DIF MAT | |
| AL | PMMA | |

Negro Preto 05 ●
Blanco opal Branco opalino M1 ○

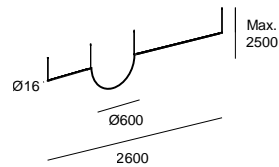

10-50 mm

87 × 244 mm (00-A150/00-A068)
108 × 314 mm (00-A151/00-A069)

18 mm

LED | CRI 92 | W Total 40

| | K | Real Lm | Structure | Difusor | Code |
|--|----------------------|---------|-----------|---------|-------------------------|
| | | | | | |
| | ON-OFF 220-240V 2700 | 3316 | 05 ● | M1 ○ | 00-A150-05-M1 QS |
| | DALI 100-240V 2700 | 3316 | 05 ● | M1 ○ | 00-A151-05-M1 QS |
| | ON-OFF 100-240V 2700 | 3316 | 05 ● | M1 ○ | 00-A152-05-M1 QS |
| | DALI 100-240V 2700 | 3316 | 05 ● | M1 ○ | 00-A153-05-M1 QS |
| | ON-OFF 220-240V 3000 | 3813 | 05 ● | M1 ○ | 00-A068-05-M1 QS |
| | DALI 100-240V 3000 | 3813 | 05 ● | M1 ○ | 00-A069-05-M1 QS |
| | ON-OFF 100-240V 3000 | 3813 | 05 ● | M1 ○ | 00-A070-05-M1 QS |
| | DALI 100-240V 3000 | 3813 | 05 ● | M1 ○ | 00-A071-05-M1 QS |

Tubs Modular Pendant Lineal Triangular

| | | | |
|----------|---------|--|------|
| BODY MAT | DIF MAT | | |
| AL | PMMA | | 360° |

Negro Preto 05 ●
Blanco opal Branco opalino M1 ○

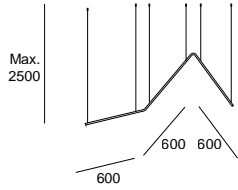

LED | CRI 92 | W Total 26.4

10-50 mm

87 × 244 mm (00-A168/00-A080)
108 × 314 mm (00-A169/00-A081)

18 mm

| | | K | Real Lm | Structure | Difussor | Code |
|--|-----------------|------|---------|-----------|----------|-------------------------|
| | ON-OFF 220-240V | 2700 | 2178 | 05 ● | M1 ○ | 00-A168-05-M1 QS |
| | DALI 100-240V | 2700 | 2178 | 05 ● | M1 ○ | 00-A169-05-M1 |
| | ON-OFF 100-240V | 2700 | 2178 | 05 ● | M1 ○ | 00-A170-05-M1 QS |
| | DALI 100-240V | 2700 | 2178 | 05 ● | M1 ○ | 00-A171-05-M1 |
| | ON-OFF 220-240V | 3000 | 2505 | 05 ● | M1 ○ | 00-A080-05-M1 QS |
| | DALI 100-240V | 3000 | 2505 | 05 ● | M1 ○ | 00-A081-05-M1 |
| | ON-OFF 100-240V | 3000 | 2505 | 05 ● | M1 ○ | 00-A082-05-M1 QS |
| | DALI 100-240V | 3000 | 2505 | 05 ● | M1 ○ | 00-A083-05-M1 |

Tubs Modular Pendant Double Triangular

| | | | |
|----------|---------|--|------|
| BODY MAT | DIF MAT | | |
| AL | PMMA | | 360° |

Negro Preto 05 ●
Blanco opal Branco opalino M1 ○

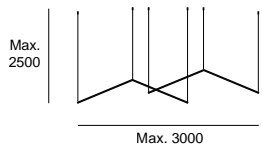

LED | CRI 92 | W Total 52.4

10-50 mm

87 × 244 mm (00-A172/00-A084)
108 × 314 mm (00-A173/00-A085)

18 mm

| | | K | Real Lm | Structure | Difussor | Code |
|--|-----------------|------|---------|-----------|----------|-------------------------|
| | ON-OFF 220-240V | 2700 | 4360 | 05 ● | M1 ○ | 00-A172-05-M1 QS |
| | DALI 100-240V | 2700 | 4360 | 05 ● | M1 ○ | 00-A173-05-M1 |
| | ON-OFF 100-240V | 2700 | 4360 | 05 ● | M1 ○ | 00-A174-05-M1 QS |
| | DALI 100-240V | 2700 | 4360 | 05 ● | M1 ○ | 00-A175-05-M1 |
| | ON-OFF 220-240V | 3000 | 5012 | 05 ● | M1 ○ | 00-A084-05-M1 QS |
| | DALI 100-240V | 3000 | 5012 | 05 ● | M1 ○ | 00-A085-05-M1 |
| | ON-OFF 100-240V | 3000 | 5012 | 05 ● | M1 ○ | 00-A086-05-M1 QS |
| | DALI 100-240V | 3000 | 5012 | 05 ● | M1 ○ | 00-A087-05-M1 |

Tubs Modular Pendant Hexagonal

| | | | |
|----------|---------|--|------|
| BODY MAT | DIF MAT | | |
| AL | PMMA | | 360° |

Negro Preto 05 ●
Blanco opal Branco opalino M1 ○

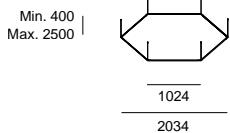

LED | CRI 92 | W Total 78.6

10-50 mm

92 × 304 mm

18 mm

| | | K | Real Lm | Structure | Difussor | Code |
|--|---------------|------|---------|-----------|----------|----------------------|
| | DALI 100-240V | 2700 | 6540 | 05 ● | M1 ○ | 00-A130-05-M1 |
| | DALI 100-240V | 3000 | 7518 | 05 ● | M1 ○ | 00-8276-05-M1 |
| | DALI 100-240V | 2700 | 6540 | 05 ● | M1 ○ | 00-A131-05-M1 |
| | DALI 100-240V | 3000 | 7518 | 05 ● | M1 ○ | 00-A056-05-M1 |

Tubs Modular Pendant Molecular

| | | | |
|----------|---------|--|------|
| BODY MAT | DIF MAT | | |
| AL | PMMA | | 360° |

Negro Preto 05 ●
Blanco opal Branco opalino M1 ○

LED | CRI 92 | W Total 99.4

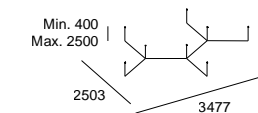

10-50 mm

92 × 304 mm

18 mm

| | | K | Real Lm | Structure | Difussor | Code |
|--|---------------|------|---------|-----------|----------|----------------------|
| | DALI 100-240V | 2700 | 5450 | 05 ● | M1 ○ | 00-A132-05-M1 |
| | DALI 100-240V | 3000 | 58771 | 05 ● | M1 ○ | 00-8280-05-M1 |
| | DALI 100-240V | 2700 | 5450 | 05 ● | M1 ○ | 00-A133-05-M1 |
| | DALI 100-240V | 3000 | 58771 | 05 ● | M1 ○ | 00-A057-05-M1 |

Tubs Modular Pendant Configuration Lineal x 5

| | | | |
|----------|---------|--|------|
| BODY MAT | DIF MAT | | |
| AL | PMMA | | 360° |

Negro Preto 05 ●
Blanco opal Branco opalino M1 ○

LED | CRI 92 | W Total 44

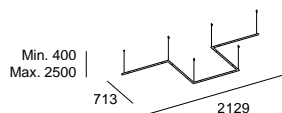

10-50 mm

84 × 314 mm (00-A136/00-8285)
87 × 244 mm (00-A137/00-8301)

18 mm

| | | K | Real Lm | Structure | Difussor | Code |
|--|-----------------|------|---------|-----------|----------|-------------------------|
| | ON-OFF 220-240V | 2700 | 3630 | 05 ● | M1 ○ | 00-A144-05-M1 QS |
| | DALI 100-240V | 2700 | 3630 | 05 ● | M1 ○ | 00-A136-05-M1 |
| | ON-OFF 100-240V | 2700 | 3630 | 05 ● | M1 ○ | 00-A145-05-M1 QS |
| | DALI 100-240V | 2700 | 3630 | 05 ● | M1 ○ | 00-A137-05-M1 |
| | ON-OFF 220-240V | 3000 | 4175 | 05 ● | M1 ○ | 00-8301-05-M1 QS |
| | DALI 100-240V | 3000 | 4175 | 05 ● | M1 ○ | 00-8285-05-M1 |
| | ON-OFF 100-240V | 3000 | 4175 | 05 ● | M1 ○ | 00-A063-05-M1 QS |
| | DALI 100-240V | 3000 | 4175 | 05 ● | M1 ○ | 00-A059-05-M1 |

Tubs Modular Pendant Track with 4 Spotlights

| | | | |
|----------|---------|--|------|
| BODY MAT | DIF MAT | | |
| AL | PMMA | | 360° |

Negro Preto 05 ●
Blanco opal Branco opalino M1 ○

LED | CRI 92 | W Total 15

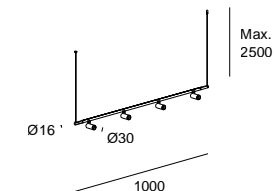

10-50 mm

87 × 244 mm (00-A197/00-A108)
108 × 314 mm (00-A199/00-A109)

18 mm

| | | K | Real Lm | Structure | Difussor | Code |
|--|-----------------|------|---------|-----------|----------|-------------------------|
| | ON-OFF 220-240V | 2700 | 1152 | 05 ● | M1 ○ | 00-A196-05-M1 QS |
| | DALI 100-240V | 2700 | 1152 | 05 ● | M1 ○ | 00-A197-05-M1 |
| | ON-OFF 100-240V | 2700 | 1152 | 05 ● | M1 ○ | 00-A198-05-M1 QS |
| | DALI 100-240V | 2700 | 1152 | 05 ● | M1 ○ | 00-A199-05-M1 |
| | ON-OFF 220-240V | 3000 | 1204 | 05 ● | M1 ○ | 00-A108-05-M1 QS |
| | DALI 100-240V | 3000 | 1204 | 05 ● | M1 ○ | 00-A109-05-M1 |
| | ON-OFF 100-240V | 3000 | 1204 | 05 ● | M1 ○ | 00-A110-05-M1 QS |
| | DALI 100-240V | 3000 | 1324 | 05 ● | M1 ○ | 00-A111-05-M1 |

Tubs Modular Pendant Track with 3 Disc

| | | | |
|----------|---------|--|------|
| BODY MAT | DIF MAT | | |
| AL | PMMA | | 360° |

Negro Preto 05 ●
Blanco opal Branco opalino M1 ○

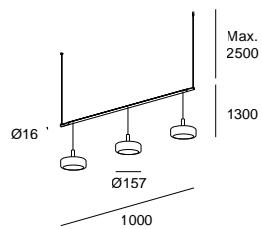

LED | CRI 92 | W Total 16

10-50 mm

87 × 244 mm (00-A200/00-A112)
108 × 314 mm (00-A201/00-A113)

18 mm

| | | K | Real Lm | Structure | Difussor | Code |
|--|-----------------|------|---------|-----------|----------|-------------------------|
| | ON-OFF 220-240V | 2700 | 183 | 05 ● | M1 ○ | 00-A200-05-M1 QS |
| | DALI 100-240V | 2700 | 183 | 05 ● | M1 ○ | 00-A201-05-M1 |
| | ON-OFF 100-240V | 2700 | 183 | 05 ● | M1 ○ | 00-A202-05-M1 QS |
| | DALI 100-240V | 2700 | 183 | 05 ● | M1 ○ | 00-A203-05-M1 |
| | ON-OFF 220-240V | 3000 | 210 | 05 ● | M1 ○ | 00-A112-05-M1 QS |
| | DALI 100-240V | 3000 | 192 | 05 ● | M1 ○ | 00-A113-05-M1 |
| | ON-OFF 100-240V | 3000 | 210 | 05 ● | M1 ○ | 00-A114-05-M1 QS |
| | DALI 100-240V | 3000 | 192 | 05 ● | M1 ○ | 00-A115-05-M1 |

Tubs Modular Pendant Track with 5 Spheres

| | | | |
|----------|---------|--|------|
| BODY MAT | DIF MAT | | |
| AL | PMMA | | 360° |

Negro Preto 05 ●
Blanco opal Branco opalino M1 ○

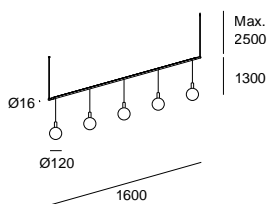

LED | CRI 92 | W Total 26.5

10-50 mm

87 × 244 mm (00-A204/00-A116)
108 × 314 mm (00-A205/00-A117)

18 mm

| | | K | Real Lm | Structure | Difussor | Code |
|--|-----------------|------|---------|-----------|----------|-------------------------|
| | ON-OFF 220-240V | 2700 | 305 | 05 ● | M1 ○ | 00-A204-05-M1 QS |
| | DALI 100-240V | 2700 | 305 | 05 ● | M1 ○ | 00-A205-05-M1 |
| | ON-OFF 100-240V | 2700 | 305 | 05 ● | M1 ○ | 00-A206-05-M1 QS |
| | DALI 100-240V | 2700 | 305 | 05 ● | M1 ○ | 00-A207-05-M1 |
| | ON-OFF 220-240V | 3000 | 350 | 05 ● | M1 ○ | 00-A116-05-M1 QS |
| | DALI 100-240V | 3000 | 320 | 05 ● | M1 ○ | 00-A117-05-M1 |
| | ON-OFF 100-240V | 3000 | 350 | 05 ● | M1 ○ | 00-A118-05-M1 QS |
| | DALI 100-240V | 3000 | 320 | 05 ● | M1 ○ | 00-A119-05-M1 |

Tubs Modular Pendant Lineal with 3 Downlights

| | | | |
|----------|---------|--|------|
| BODY MAT | DIF MAT | | |
| AL | PMMA | | 360° |

Negro Preto 05 ●
Blanco opal Branco opalino M1 ○

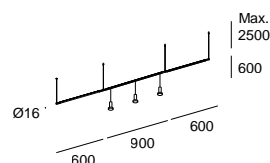

LED | CRI 92 | W Total 33.5

10-50 mm

87 × 244 mm (00-A192/00-A104)
108 × 314 mm (00-A193/00-A105)

18 mm

| | | K | Real Lm | Structure | Difussor | Code |
|--|-----------------|------|---------|-----------|----------|-------------------------|
| | ON-OFF 220-240V | 2700 | 1638 | 05 ● | M1 ○ | 00-A192-05-M1 QS |
| | DALI 100-240V | 2700 | 1638 | 05 ● | M1 ○ | 00-A193-05-M1 |
| | ON-OFF 100-240V | 2700 | 1638 | 05 ● | M1 ○ | 00-A194-05-M1 QS |
| | DALI 100-240V | 2700 | 1638 | 05 ● | M1 ○ | 00-A195-05-M1 |
| | ON-OFF 220-240V | 3000 | 1880 | 05 ● | M1 ○ | 00-A104-05-M1 QS |
| | DALI 100-240V | 3000 | 1880 | 05 ● | M1 ○ | 00-A105-05-M1 |
| | ON-OFF 100-240V | 3000 | 1880 | 05 ● | M1 ○ | 00-A106-05-M1 QS |
| | DALI 100-240V | 3000 | 1880 | 05 ● | M1 ○ | 00-A107-05-M1 |

Tubs Modular Pendant Track with 2 Lineal

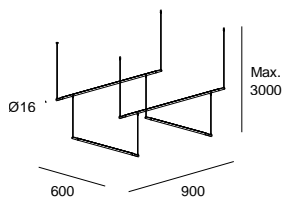

10-50 mm

87 × 244 mm (00-A184/00-A096)
108 × 314 mm (00-A185-00-A097)

18 mm



LED | CRI 92 | W Total 17.6

Negro Preto 05 ●
Blanco opal Branco opalino M1 ○

| | | K | Real Lm | Structure | Difussor | Code |
|--|-----------------|------|---------|-----------|----------|-------------------------|
| | ON-OFF 220-240V | 2700 | 1452 | 05 ● | M1 ○ | 00-A184-05-M1 QS |
| | DALI 100-240V | 2700 | 1452 | 05 ● | M1 ○ | 00-A185-05-M1 |
| | ON-OFF 100-240V | 2700 | 1452 | 05 ● | M1 ○ | 00-A186-05-M1 QS |
| | DALI 100-240V | 2700 | 1452 | 05 ● | M1 ○ | 00-A187-05-M1 |
| | ON-OFF 220-240V | 3000 | 1670 | 05 ● | M1 ○ | 00-A096-05-M1 QS |
| | DALI 100-240V | 3000 | 1670 | 05 ● | M1 ○ | 00-A097-05-M1 |
| | ON-OFF 100-240V | 3000 | 1670 | 05 ● | M1 ○ | 00-A098-05-M1 QS |
| | DALI 100-240V | 3000 | 1670 | 05 ● | M1 ○ | 00-A099-05-M1 |

Tubs Modular Pendant Track with 3 Lineal

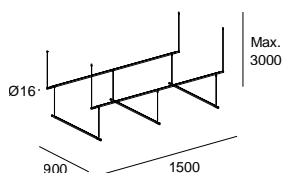

10-50 mm

87 × 244 mm (00-A188/00-A100)
108 × 314 mm (00-A189/00-A101)

18 mm



LED | CRI 92 | W Total 39.3

Negro Preto 05 ●
Blanco opal Branco opalino M1 ○

| | | K | Real Lm | Structure | Difussor | Code |
|--|-----------------|------|---------|-----------|----------|-------------------------|
| | ON-OFF 220-240V | 2700 | 3270 | 05 ● | M1 ○ | 00-A188-05-M1 QS |
| | DALI 100-240V | 2700 | 3270 | 05 ● | M1 ○ | 00-A189-05-M1 |
| | ON-OFF 100-240V | 2700 | 3270 | 05 ● | M1 ○ | 00-A190-05-M1 QS |
| | DALI 100-240V | 2700 | 3270 | 05 ● | M1 ○ | 00-A191-05-M1 |
| | ON-OFF 220-240V | 3000 | 3759 | 05 ● | M1 ○ | 00-A100-05-M1 QS |
| | DALI 100-240V | 3000 | 3759 | 05 ● | M1 ○ | 00-A101-05-M1 |
| | ON-OFF 100-240V | 3000 | 3759 | 05 ● | M1 ○ | 00-A102-05-M1 QS |
| | DALI 100-240V | 3000 | 3759 | 05 ● | M1 ○ | 00-A103-05-M1 |

Suspensión

Suspensão



Voiles

082



Levels

086



Ilargi

092



Plat

098



Iris

095



Khoi

100



Glam

102



Gong

104



Veneto

120



Coco

112



Shoemaker

116



Nimes

122

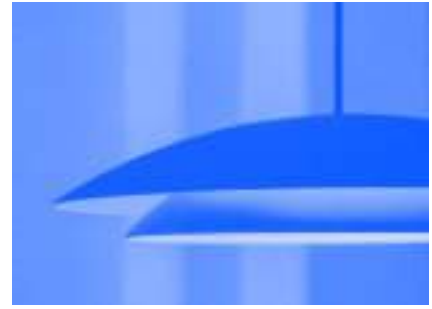

Noway

124



Keops

126



Attic

129



Super Attic

136



H

140



Candle

145



Napa

143



Invisible

151



Dew

156



Prolix

154



Punto

162



Alive

159



Mist

164



Circ

165



Pipe

170



Caprice

168



Stylus

172



Bravo

174



Bol

177

Voiles



Performance Universe



Artesanal y contemporánea

Voiles es una pieza contemporánea realizada de forma artesanal siguiendo una técnica de elaboración milenaria con el papel japonés washi. La diseñadora Céline Wright se ha inspirado en sus travesías en barco, mientras contemplaba las velas que dirigen el viento en alta mar. Voiles cuenta con delicadas piezas superpuestas que crean dibujos y sombras gracias a esta técnica artesanal.

Artesanal e contemporânea

Voiles é uma peça contemporânea realizada de forma artesanal utilizando uma técnica de elaboração milenar com o papel japonês washi. A designer Céline Wright inspirou-se nas suas viagens de barco enquanto contemplava as velas que dirigiam o vento no alto-mar. Voiles apresenta delicadas peças sobrepostas que criam padrões e sombras graças a esta técnica artesanal.



Voiles Small Surface

| | |
|----------|---------|
| BODY MAT | DIF MAT |
| ST | WASHI |

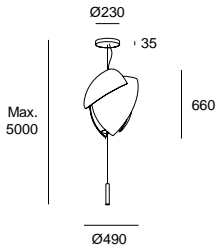

LED | CRI 92 | Real Lm 2357

Blanco Branco 14

Cromo Cromado 21

| | K | W Total | Structure | Body | Code |
|-----------------------|------|---------|-------------------------------------|--------------------------|----------------------|
| 1-10V 100-240V | 2700 | 36 | 21 <input checked="" type="radio"/> | 14 <input type="radio"/> | 00-7692-21-14 |
| PHASE CUT 220-240V | 2700 | 37.8 | 21 <input checked="" type="radio"/> | 14 <input type="radio"/> | 00-7691-21-14 |
| DALI 100-277V | 2700 | 38.1 | 21 <input checked="" type="radio"/> | 14 <input type="radio"/> | 00-7693-21-14 |
| 1-10V 100-240V | 3000 | 36 | 21 <input checked="" type="radio"/> | 14 <input type="radio"/> | 00-6307-21-14 |
| PHASE CUT 220-240V | 3000 | 37.8 | 21 <input checked="" type="radio"/> | 14 <input type="radio"/> | 00-6306-21-14 |
| DALI 100-277V | 3000 | 38.1 | 21 <input checked="" type="radio"/> | 14 <input type="radio"/> | 00-6308-21-14 |

Voiles Small Recessed

| | |
|----------|---------|
| BODY MAT | DIF MAT |
| ST | WASHI |

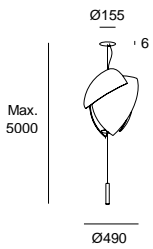

LED | CRI 92 | Real Lm 2357

Blanco Branco 14

Cromo Cromado 21

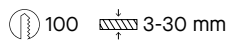

| | K | W Total | Structure | Body | Code |
|-----------------------|------|---------|-------------------------------------|--------------------------|----------------------|
| 1-10V 100-240V | 2700 | 36 | 21 <input checked="" type="radio"/> | 14 <input type="radio"/> | 00-7695-21-14 |
| PHASE CUT 220-240V | 2700 | 37.8 | 21 <input checked="" type="radio"/> | 14 <input type="radio"/> | 00-7694-21-14 |
| DALI 100-277V | 2700 | 38.1 | 21 <input checked="" type="radio"/> | 14 <input type="radio"/> | 00-7696-21-14 |
| 1-10V 100-240V | 3000 | 36 | 21 <input checked="" type="radio"/> | 14 <input type="radio"/> | 00-6318-21-14 |
| PHASE CUT 220-240V | 3000 | 37.8 | 21 <input checked="" type="radio"/> | 14 <input type="radio"/> | 00-6317-21-14 |
| DALI 100-277V | 3000 | 38.1 | 21 <input checked="" type="radio"/> | 14 <input type="radio"/> | 00-6319-21-14 |

Voiles Big Surface

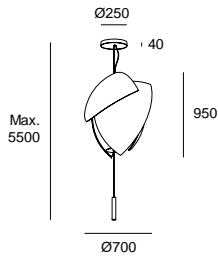
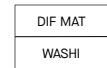

LED | CRI 92 | Real Lm 4032

Blanco Branco 14
Cromo Cromado 21

| | K | W Total | Structure | Body | Code |
|-----------------------|------|---------|--------------------------|--------------------------|----------------------|
| DALI 220-240V | 2700 | 52.2 | 21 <input type="radio"/> | 14 <input type="radio"/> | 00-7687-21-14 |
| 1-10V 100-240V | 2700 | 53.5 | 21 <input type="radio"/> | 14 <input type="radio"/> | 00-7686-21-14 |
| PHASE CUT 220-240V | 2700 | 56.6 | 21 <input type="radio"/> | 14 <input type="radio"/> | 00-7685-21-14 |
| DALI 220-240V | 3000 | 52.2 | 21 <input type="radio"/> | 14 <input type="radio"/> | 00-6305-21-14 |
| 1-10V 100-240V | 3000 | 53.5 | 21 <input type="radio"/> | 14 <input type="radio"/> | 00-6304-21-14 |
| PHASE CUT 220-240V | 3000 | 56.6 | 21 <input type="radio"/> | 14 <input type="radio"/> | 00-6303-21-14 |

Voiles Big Recessed

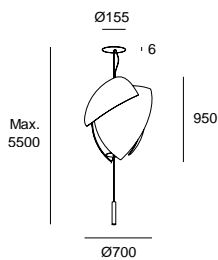
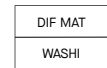

LED | CRI 92 | Real Lm 4032

Blanco Branco 14
Cromo Cromado 21

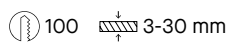

| | K | W Total | Structure | Body | Code |
|-----------------------|------|---------|--------------------------|--------------------------|----------------------|
| DALI 220-240V | 2700 | 52.2 | 21 <input type="radio"/> | 14 <input type="radio"/> | 00-7690-21-14 |
| 1-10V 100-240V | 2700 | 53.5 | 21 <input type="radio"/> | 14 <input type="radio"/> | 00-7689-21-14 |
| PHASE CUT 220-240V | 2700 | 56.6 | 21 <input type="radio"/> | 14 <input type="radio"/> | 00-7688-21-14 |
| DALI 220-240V | 3000 | 52.2 | 21 <input type="radio"/> | 14 <input type="radio"/> | 00-6316-21-14 |
| 1-10V 100-240V | 3000 | 53.5 | 21 <input type="radio"/> | 14 <input type="radio"/> | 00-6315-21-14 |
| PHASE CUT 220-240V | 3000 | 56.6 | 21 <input type="radio"/> | 14 <input type="radio"/> | 00-6314-21-14 |

Voiles Pendant & Ceiling

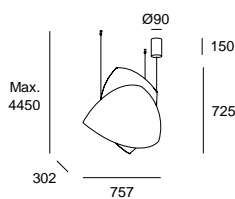
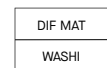

LED | K 2700 | CRI 92 | W Total 33.6 | Real Lm 1864

Blanco Branco 14
Cromo Cromado 21

| | Structure | Body | Code |
|--------------------------------|--------------------------|--------------------------|----------------------|
| 0-10V / 1-10V / DALI2 110-240V | 21 <input type="radio"/> | 14 <input type="radio"/> | 15-7723-21-14 |

Levels



Performance Universe



P. 212



P. 250



P. 328



Una luz con gran carisma

Levels hace gala de un carácter camaleónico, en cualquiera de sus composiciones, no sólo por la finura de sus formas, sino también por la diversidad de sus temperaturas de color y su eficiencia lumínica. Con una amplia familia formada por versiones de colgante, plafón, sobremesa y pie de salón, presenta tres niveles de composición posibles con diferentes transparencias, que pueden utilizarse individualmente, de forma doble o triple creando nuevas adiciones de color y grados de transparencia.

Uma luz com grande carisma

Levels faz gala de um caráter camaleônico, em qualquer uma das suas composições, não só pela delicadeza das suas formas, mas também pela diversidade das suas temperaturas de cor e a sua eficiência lumínica. Com uma ampla família formada por versões de suspensão, plafon, de mesa e candeeiro de pé, apresenta três níveis possíveis de composição com diferentes transparências que podem ser utilizados individualmente, de forma dupla ou tripla, criando novas adições de cor e graus de transparência.





El corazón de Levels reside en su difusor de vidrio soplado artesanalmente: una pieza única, con variaciones propias del proceso manual, cuya transparencia y textura convierten la luz en un gesto orgánico, elegante y casi escultórico.

O coração de Levels encontra-se no seu difusor de vidro soprado à mão: uma peça única, com variações próprias do processo manual, cuja transparência e textura transformam a luz num gesto orgânico, elegante e quase escultural.

Levels ofrece tres temperaturas de color —2700K, 3000K y 4000K— para adaptar la luz a cada ambiente.

Levels oferece três temperaturas de cor – 2700K, 3000K e 4000K – para adaptar a luz a cada ambiente.



2700K



3000K



4000K



Levels combina tres grados de transparencia, 30%, 50% y 70%.

Con tres acabados de vidrio, verde, fumé y ámbar, para modular la luz, el volumen y los matices cálidos que definen cada composición.

“Levels combina três graus de transparência, 30%, 50% e 70%.

Com três acabamentos em vidro, verde, fumé e âmbar, para modular a luz, o volume e as nuances quentes que definem cada composição.”



Levels 1 Body Ø220mm

QS

| |
|----------|
| BODY MAT |
| ST |

| |
|---------|
| DIF MAT |
| GLA |



| |
|----------------|
| SWITCH CCT |
| 2700-3000-4000 |

| | | |
|-------------|----|---|
| Negro Preto | 05 | ● |
| Verde Verde | 08 | ● |
| Fumé Fumado | 12 | ● |
| Âmbar Âmbar | 15 | ● |

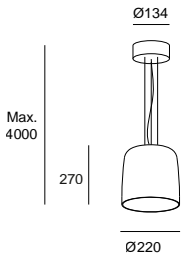

LED | K 2700-3000-4000 | CRI 92 | W Total 19 | Real Lm 1381 (3000K)

| | Structure | Difussor | Code |
|--------------------|-----------|----------|----------------------|
| PHASE CUT 220-240V | 05 ● | 08 ● | 00-A024-05-08 |
| | 05 ● | 12 ● | 00-A024-05-12 |
| | 05 ● | 15 ● | 00-A024-05-15 |
| DALI-2 110-277V | 05 ● | 08 ● | 00-A042-05-08 |
| | 05 ● | 12 ● | 00-A042-05-12 |
| | 05 ● | 15 ● | 00-A042-05-15 |

Levels 1 Body Ø320mm

QS

| |
|----------|
| BODY MAT |
| ST |

| |
|---------|
| DIF MAT |
| GLA |



| |
|----------------|
| SWITCH CCT |
| 2700-3000-4000 |

| | | |
|-------------|----|---|
| Negro Preto | 05 | ● |
| Verde Verde | 08 | ● |
| Fumé Fumado | 12 | ● |
| Âmbar Âmbar | 15 | ● |

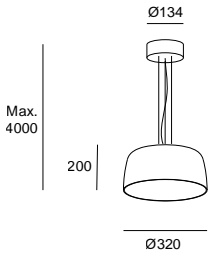

LED | K 2700-3000-4000 | CRI 92 | W Total 19 | Real Lm 1381 (3000K)

| | Structure | Difussor | Code |
|--------------------|-----------|----------|----------------------|
| PHASE CUT 220-240V | 05 ● | 08 ● | 00-A025-05-08 |
| | 05 ● | 12 ● | 00-A025-05-12 |
| | 05 ● | 15 ● | 00-A025-05-15 |
| DALI-2 110-277V | 05 ● | 08 ● | 00-A043-05-08 |
| | 05 ● | 12 ● | 00-A043-05-12 |
| | 05 ● | 15 ● | 00-A043-05-15 |

Levels 1 Body Ø420mm

QS

| |
|----------|
| BODY MAT |
| ST |

| |
|---------|
| DIF MAT |
| GLA |



| |
|----------------|
| SWITCH CCT |
| 2700-3000-4000 |

| | | |
|-------------|----|---|
| Negro Preto | 05 | ● |
| Verde Verde | 08 | ● |
| Fumé Fumado | 12 | ● |
| Âmbar Âmbar | 15 | ● |

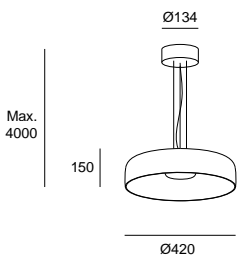

LED | K 2700-3000-4000 | CRI 92 | W Total 19 | Real Lm 1381 (3000K)

| | Structure | Difussor | Code |
|--------------------|-----------|----------|----------------------|
| PHASE CUT 220-240V | 05 ● | 08 ● | 00-A026-05-08 |
| | 05 ● | 12 ● | 00-A026-05-12 |
| | 05 ● | 15 ● | 00-A026-05-15 |
| DALI-2 110-277V | 05 ● | 08 ● | 00-A044-05-08 |
| | 05 ● | 12 ● | 00-A044-05-12 |
| | 05 ● | 15 ● | 00-A044-05-15 |

*Los acabados y tonalidad mostrados pueden no ser completamente precisos debido a ligeras variaciones en la producción, factores de iluminación, fotográficas e impresión.

*Os acabamentos e tonalidades apresentados podem não ser totalmente precisos, devido a ligeiras variações na produção, fatores de iluminação fotográfica e de impressão.

Levels 2 Bodies Ø320mm + Ø220mm

QS

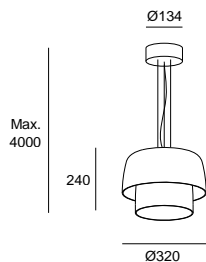

| | | | |
|----------|---------|--|----------------|
| BODY MAT | DIF MAT | | SWITCH CCT |
| ST | GLA | | 2700-3000-4000 |

| | | |
|-------------|----|--|
| Negro Preto | 05 | |
| Verde Verde | 08 | |
| Fumé Fumado | 12 | |
| Ámbar Âmbar | 15 | |

LED | K 2700-3000-4000 | CRI 92 | W Total 19 | Real Lm 1381 (3000K)

| | Structure | Difusor | Code |
|--------------------|-----------|---------|---------------|
| PHASE CUT 220-240V | 05 | 08 | 00-A027-05-08 |
| | 05 | 12 | 00-A027-05-12 |
| | 05 | 15 | 00-A027-05-15 |
| DALI-2 110-277V | 05 | 08 | 00-A045-05-08 |
| | 05 | 12 | 00-A045-05-12 |
| | 05 | 15 | 00-A045-05-15 |

Levels 2 Bodies Ø420mm + Ø320mm

QS

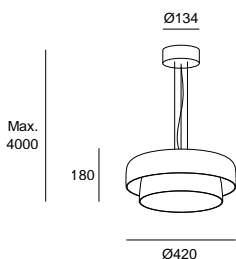

| | | | |
|----------|---------|--|----------------|
| BODY MAT | DIF MAT | | SWITCH CCT |
| ST | GLA | | 2700-3000-4000 |

| | | |
|-------------|----|--|
| Negro Preto | 05 | |
| Verde Verde | 08 | |
| Fumé Fumado | 12 | |
| Ámbar Âmbar | 15 | |

LED | K 2700-3000-4000 | CRI 92 | W Total 19 | Real Lm 1381 (3000K)

| | Structure | Difusor | Code |
|--------------------|-----------|---------|---------------|
| PHASE CUT 220-240V | 05 | 08 | 00-A028-05-08 |
| | 05 | 12 | 00-A028-05-12 |
| | 05 | 15 | 00-A028-05-15 |
| DALI-2 110-277V | 05 | 08 | 00-A046-05-08 |
| | 05 | 12 | 00-A046-05-12 |
| | 05 | 15 | 00-A046-05-15 |

Levels 3 Bodies Ø420mm + Ø320mm + Ø220mm

QS

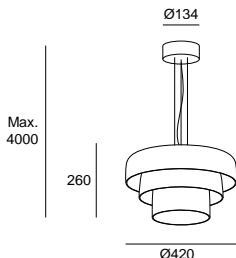

| | | | |
|----------|---------|--|----------------|
| BODY MAT | DIF MAT | | SWITCH CCT |
| ST | GLA | | 2700-3000-4000 |

| | | |
|-------------|----|--|
| Negro Preto | 05 | |
| Verde Verde | 08 | |
| Fumé Fumado | 12 | |
| Ámbar Âmbar | 15 | |

LED | K 2700-3000-4000 | CRI 92 | W Total 19 | Real Lm 1381 (3000K)

| | Structure | Difusor | Code |
|--------------------|-----------|---------|---------------|
| PHASE CUT 220-240V | 05 | 08 | 00-A041-05-08 |
| | 05 | 12 | 00-A041-05-12 |
| | 05 | 15 | 00-A041-05-15 |
| DALI-2 110-277V | 05 | 08 | 00-A047-05-08 |
| | 05 | 12 | 00-A047-05-12 |
| | 05 | 15 | 00-A047-05-15 |

Ilargi



Performance Universe



P. 218



Elegancia natural

Ilargi, creada por los diseñadores vascos Irtzoki y Lizaso, es una combinación perfecta de calidez y diseño funcional atemporal. Su cristal de vidrio soplado de manera artesanal permite regular una luz tamizada, que se combina con madera noble maciza. Su luz es suave y agradable, perfecta para uso residencial o para espacios públicos creando ambientes confortables y naturales.

Elegância natural

Ilargi, criada pelos designers bascos Irtzoki e Lizaso, é uma combinação perfeita de calidez e design funcional intemporal. A sua campânula de vidro soprado de forma artesanal permite regular a luz filtrada, que combina com a madeira nobre maciça. A sua luz é suave e agradável, perfeita para uso residencial ou para espaços públicos criando ambientes confortáveis e naturais.

Acabados en madera maciza, natural y negro.
Acabamentos em madeira maciça, natural e preto.



Ilargi Ø240

BODY MAT
ST.WOOD

DIF MAT
GLA



Fresno oscuro Cinza escura 92 ●
Fresno claro Cinza claro 93 ●
Arenado Areado F9 ○

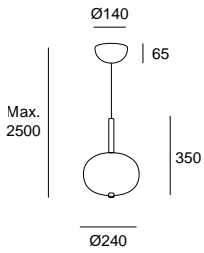

LED | K 2700 | CRI 92 | W Total 11.8 | Real Lm 641

| | Structure | Difussor | Code |
|--------------------|-----------|----------|----------------------|
| PHASE CUT 220-240V | 92 ● | F9 ○ | 00-6452-92-F9 |
| | 93 ● | F9 ○ | 00-6452-93-F9 |
| 0-10V 120-277V | 92 ● | F9 ○ | 00-6010-92-F9 |
| | 93 ● | F9 ○ | 00-6010-93-F9 |
| DALI 220-240V | 92 ● | F9 ○ | 00-6454-92-F9 |
| | 93 ● | F9 ○ | 00-6454-93-F9 |

Florón blanco
Florão branco

Ilargi Ø320

BODY MAT
ST.WOOD

DIF MAT
GLA



Fresno oscuro Cinza escura 92 ●
Fresno claro Cinza claro 93 ●
Arenado Areado F9 ○

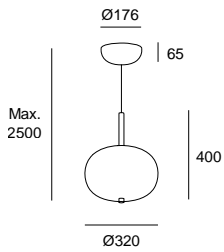

LED | K 2700 | CRI 92 | W Total 18.9 | Real Lm 1054

| | Structure | Difussor | Code |
|--------------------|-----------|----------|----------------------|
| PHASE CUT 220-240V | 92 ● | F9 ○ | 00-6455-92-F9 |
| | 93 ● | F9 ○ | 00-6455-93-F9 |
| 1-10V 120-277V | 92 ● | F9 ○ | 00-6011-92-F9 |
| | 93 ● | F9 ○ | 00-6011-93-F9 |
| DALI 220-240V | 92 ● | F9 ○ | 00-6457-92-F9 |
| | 93 ● | F9 ○ | 00-6457-93-F9 |

Florón blanco
Florão branco

Ilargi Ø395

BODY MAT
ST.WOOD

DIF MAT
GLA



Fresno oscuro Cinza escura 92 ●
Fresno claro Cinza claro 93 ●
Arenado Areado F9 ○

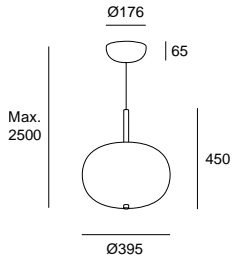

LED | K 2700 | CRI 92 | W Total 25.5 | Real Lm 1507

| | Structure | Difussor | Code |
|--------------------|-----------|----------|----------------------|
| PHASE CUT 220-240V | 92 ● | F9 ○ | 00-6458-92-F9 |
| | 93 ● | F9 ○ | 00-6458-93-F9 |
| 1-10V 100-240V | 92 ● | F9 ○ | 00-6012-92-F9 |
| | 93 ● | F9 ○ | 00-6012-93-F9 |
| DALI/PUSH 220-240V | 92 ● | F9 ○ | 00-6460-92-F9 |
| | 93 ● | F9 ○ | 00-6460-93-F9 |

Florón blanco
Florão branco

Ilargi 2 Bodies

BODY MAT
ST.WOOD

DIF MAT
GLA



Fresno oscuro Cinza escura 92 ●
Fresno claro Cinza claro 93 ●
Arenado Areado F9 ○

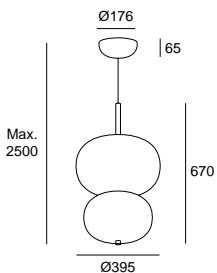

LED | K 2700 | CRI 92 | W Total 40.6 | Real Lm 1833

| | Structure | Difussor | Code |
|--------------------|-----------|----------|----------------------|
| PHASE CUT 220-240V | 92 ● | F9 ○ | 00-6461-92-F9 |
| | 93 ● | F9 ○ | 00-6461-93-F9 |
| 1-10V 100-240V | 92 ● | F9 ○ | 00-6013-92-F9 |
| | 93 ● | F9 ○ | 00-6013-93-F9 |
| DALI 100-277V | 92 ● | F9 ○ | 00-6463-92-F9 |
| | 93 ● | F9 ○ | 00-6463-93-F9 |

Florón blanco
Florão branco

Iris



Performance Universe



Arquitectural y decorativa a la vez, Iris es una colección orgánica y viva, que dialoga activamente creando diferentes ambientes y mejorándolos con su presencia a través de la luz y la percepción visual de su estructura. Sus opciones de adaptación al espacio y composición son tan amplias que forman un círculo de creación en perfecta armonía.

Arquitetural e decorativa ao mesmo tempo, Iris é uma coleção orgânica e viva que dialoga ativamente, criando diferentes ambientes e valorizando-os com a sua presença através da luz e da percepção visual da sua estrutura. As suas opções de adaptação ao espaço e composição são tão amplas que formam um círculo de criação em perfeita harmonia.



Composición mediante configurador online
Composição através de configurador online



Composición mediante configurador online
Composição através de configurador online



Composición mediante configurador online
Composição através de configurador online



Composición mediante configurador online
Composição através de configurador online

*Los acabados y tonalidad mostrados pueden no ser completamente precisos debido a ligeras variaciones en la producción, factores de iluminación, fotográficas e impresión.

*Os acabamentos e tonalidades apresentados podem não ser totalmente precisos, devido a ligeiras variações na produção, fatores de iluminação fotográfica e de impressão.

Configura tu Iris

Configure a sua Iris

Configurador para personalización disponible.
Configurador para personalização disponível.

iris.ledsc4.com



AV14

Instalación
Instalação

AV14
AV15
AV16
AV26

-P6

Potencia
Potência

P6 6.3 W
12 12.5 W
18 18.1 W

V9

Temperatura de la luz
Temperatura da luz

V9 2700K
W9 3000K
X9 4000K

U

Pantalla
Quebra-luz

U Hoop

1

Optics
Ótica

1 15°
2 35°
3 50°

OS

Fuente de alimentación
Fonte de alimentação

OS ON-OFF
DS DALI-2

60

Acabados
Acabamentos

60 O2
L9 O8

1 Instalación Installation

AV16 Surface



AV26 IP23



AV14 Trim

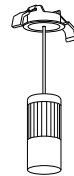

⌀ 57mm

AV15 Trimless

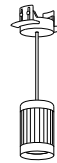

⌀ 57mm

2 Potencia Potência

P6 6.3 W 12 12.5 W 18 18.1 W

3 Temperatura de la luz Temperatura da luz

V9 2700K



W9 3000K



X9 4000K



4 Pantalla Quebra-luz

U Hoop



5 Optics Ótica

1 15° 2 35° 3 50°

6 Fuente de alimentación Fonte de alimentação

OU ON/OFF* DU DALI*

7 Acabados Acabamentos

| | 60 | L9 | O2 | O8 |
|--------------|----|----|----|----|
| Installation | ● | ● | ○ | ● |
| Module | ● | ● | ● | ● |
| Shade | ● | ● | ● | ● |

○ White Branco
● Gray Cinza
● Oro Ouro
● Negro Preto

Accesorios | Acessórios

71-5167-00-00
Difusor elíptico (5u.)
Difusor elíptico (5u.)



71-5658-00-00
Difusor cuadrado (5u.)
Difusor quadrado (5u.)



71-6099-00-00
Difuminador de halo (5u.)
Difusor opalino (5u.)



71-5166-60-00
Panel de abeja (5u.)
Painel de abelha (5u.)



71-7895-00-00
Apantallador (5u.)
Obturador assimétrico (5u.)



*Para conocer el voltaje de operación de cada referencia, consulte su respectiva ficha técnica.

*Para conhecer a voltagem de operação de cada referência, consulte sua respectiva ficha técnica.

Plat



Performance Universe



Suave elegancia

Con una trabajada pero sencilla forma ovalada soplada en vidrio artesanalmente, Plat es una propuesta que destaca precisamente por la suavidad de su diseño. En tres tonalidades diferentes, puede instalarse de forma individual o en composición.

Suavidade e elegância

Com uma trabalhada mas simples forma oval soprada de forma artesanal em vidro, Plat é uma proposta que se destaca precisamente pela suavidade do seu design. Em três tonalidades diferentes, pode ser instalada individualmente ou numa composição.



Tonalidad verde al 30%.
Matiz verde a 30%.



Tonalidad fumé al 50%.
Matiz fumé a 50%.



Tonalidad ámbar al 30%.
Matiz ámbar a 30%.

Plat Surface

QS

| | | | |
|----------|---------|--|----------------|
| BODY MAT | DIF MAT | | SWITCH CCT |
| ST | GLA | | 2700-3000-4000 |

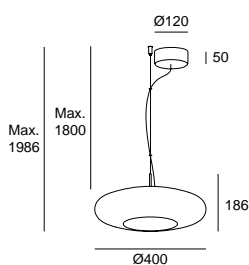

LED | K 2700-3000-4000 | CRI 92 | W Total 13 (3000K)

| | | |
|-------------|----|--|
| Negro Preto | 05 | |
| Verde Verde | 08 | |
| Fumé Fumado | 12 | |
| Ámbar Âmbar | 15 | |

| | Real Lm | Canopy | Body | Code |
|--------------------|---------|--------|------|----------------------|
| PHASE CUT 220-240V | 805 | 05 | 08 | 00-8403-05-08 |
| | 762 | 05 | 12 | 00-8403-05-12 |
| | 743 | 05 | 15 | 00-8403-05-15 |

QS Quick Service | 2-6 días laborables (tiempo de transporte no incluido)
Quick Service | 2-6 dias úteis (tempo de transporte não incluido)

Plat Recessed

| | | | |
|----------|---------|--|----------------|
| BODY MAT | DIF MAT | | SWITCH CCT |
| ST | GLA | | 2700-3000-4000 |

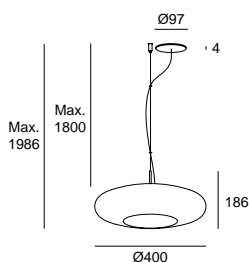

LED | K 2700-3000-4000 | CRI 92 | W Total 13 (3000K)

| | | |
|-------------|----|--|
| Negro Preto | 05 | |
| Verde Verde | 08 | |
| Fumé Fumado | 12 | |
| Ámbar Âmbar | 15 | |

| | Real Lm | Canopy | Body | Code |
|--------------------|---------|--------|------|----------------------|
| PHASE CUT 220-240V | 805 | 05 | 08 | 00-8405-05-08 |
| | 762 | 05 | 12 | 00-8405-05-12 |
| | 743 | 05 | 15 | 00-8405-05-15 |
| DALI-2 220-240V | 805 | 05 | 08 | 00-8406-05-08 |
| | 762 | 05 | 12 | 00-8406-05-12 |
| | 743 | 05 | 15 | 00-8406-05-15 |

65 3-30 mm

*Los acabados y tonalidad mostrados pueden no ser completamente precisos debido a ligeras variaciones en la producción, factores de iluminación, fotográficas e impresión.

*Os acabamentos e tonalidades apresentados podem não ser totalmente precisos, devido a ligeiras variações na produção, fatores de iluminação fotográfica e de impressão.

Khoi



Performance Universe



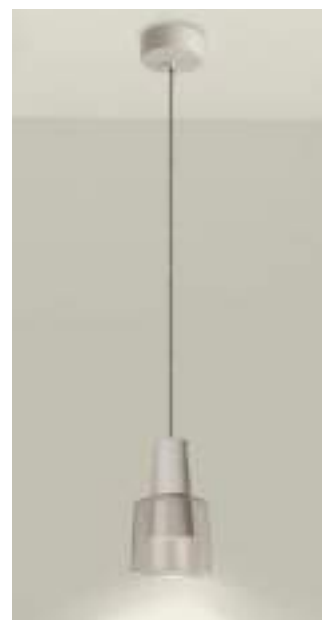

Khoi Surface

QS

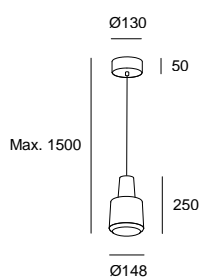

LED | K 3000 | CRI 80 | W Total 22.7 | Real Lm 907



ON-OFF 220-240V

Body Difussor Code

14 CS

37 12

| | | |
|----------|---------|--|
| BODY MAT | DIF MAT | |
| AL | GLA | |

| | | |
|-------------------------------|----|-----------------------|
| Blanco Branco | 14 | <input type="radio"/> |
| Gris cemento Cinzento cimento | CS | <input type="radio"/> |
| Transparente Transparente | 37 | <input type="radio"/> |
| Fumé Fumado | 12 | <input type="radio"/> |

00-A015-14-37
00-A015-CS-12

Khoi Recessed

QS

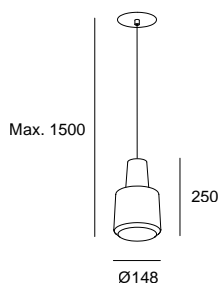

LED | K 3000 | CRI 80 | W Total 22.7 | Real Lm 907



ON-OFF 220-240V

Body Difussor Code

14 CS

37 12

| | | |
|----------|---------|--|
| BODY MAT | DIF MAT | |
| AL | GLA | |

| | | |
|-------------------------------|----|-----------------------|
| Blanco Branco | 14 | <input type="radio"/> |
| Gris cemento Cinzento cimento | CS | <input type="radio"/> |
| Transparente Transparente | 37 | <input type="radio"/> |
| Fumé Fumado | 12 | <input type="radio"/> |

00-A016-14-37
00-A016-CS-12

3-30 mm 65

*Los acabados y tonalidad mostrados pueden no ser completamente precisos debido a ligeras variaciones en la producción, factores de iluminación, fotográficas e impresión.

*Os acabamentos e tonalidades apresentados podem não ser totalmente precisos, devido a ligeiras variações na produção, fatores de iluminação fotográfica e de impressão.

Glam



Performance Universe



Elegancia natural

Personalidad y elegancia son algunos de los atributos de Glam. Realizada en vidrio soplado, el resultado es una colección integradora que propicia un ambiente agradable, cálido y con carácter.

Elegância natural

Personalidade e elegância são alguns dos atributos de Glam. Realizada em vidro soprado, o resultado é uma coleção integradora que cria um ambiente agradável, acolhedor e com caráter.

*Los acabados y tonalidad mostrados pueden no ser completamente precisos debido a ligeras variaciones en la producción, factores de iluminación, fotográficas e impresión.

*Os acabamentos e tonalidades apresentados podem não ser totalmente precisos, devido a ligeiras variações na produção, fatores de iluminação fotográfica e de impressão.

Disponible en dos medidas.
Disponível em duas medidas.

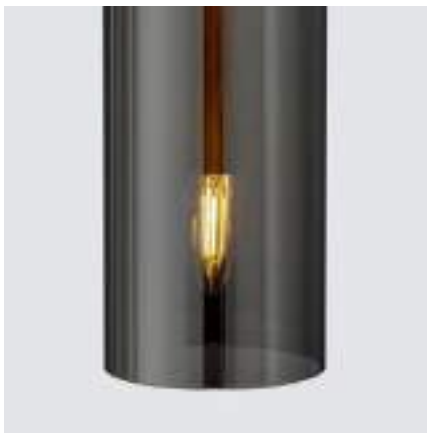

Vidrio soplado de forma artesanal.
Vidro soprado de forma artesanal.

Glam 310mm

QS

| | | |
|----------|---------|--|
| BODY MAT | DIF MAT | |
| ST | GLA | |

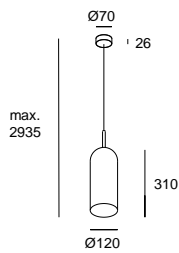

E14 | W Max. 9

- Blanco Branco 14
- Oro mate Ouro mate DN
- Fumé Fumado 12

| Structure | Body | Code |
|-----------|------|----------------------|
| DN | 12 | 00-8107-DN-12 |
| DN | 14 | 00-8107-DN-14 |

Glam 385mm

QS

| | | |
|----------|---------|--|
| BODY MAT | DIF MAT | |
| ST | GLA | |

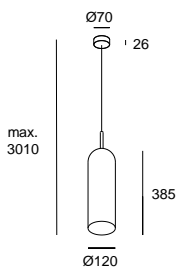

E14 | W Max. 9

- Blanco Branco 14
- Oro mate Ouro mate DN
- Fumé Fumado 12

| Structure | Body | Code |
|-----------|------|----------------------|
| DN | 12 | 00-8108-DN-12 |
| DN | 14 | 00-8108-DN-14 |

Gong



Performance Universe



P. 332



Calidez y luz ambiental: pureza e innovación en el uso de materiales

Gong es una luminaria que sorprende, apropiándose de los espacios con una luz tamizada que se filtra de forma sugerente a través del tejido de su campana. Carisma y honestidad definen este diseño de Francesc Vilaró. Además de aportar una sensibilidad especial jugando con la vista y el tacto, el diseño de Gong está pensado para ofrecer un alto rendimiento lumínico en un cuerpo decorativo. Con tres acabados estándar y opciones personalizadas de tejido bajo pedido, Gong destaca por su carácter único, tanto si está encendida como apagada.

Calor e luz ambiente: pureza e inovação na utilização dos materiais

Gong é uma luminária que surpreende, apropriando-se dos espaços com uma luz que é filtrada de forma sugestiva através do tecido da sua campânula. Carisma e honestidade definem este design Francesc Vilaró. Além de proporcionar uma sensibilidade especial jogando com a visão e o tato, o design de Gong destinase a oferecer um alto rendimento lumínico num corpo decorativo. Com três acabamentos standard e opções de tecido personalizadas sob pedido, Gong destaca-se pelo seu carácter único, quer esteja ligada ou desligada.





El alma de Gong reside en su tejido, un material artesanal y duradero, resistente a la abrasión e ignífugo.

A alma de Gong reside no seu tecido, um material artesanal, duradouro, resistente à abrasão e ignífugo.

Gong se presenta en tres acabados inspirados en la naturaleza —arena, terracota y carbón— con marco metálico a juego para una imagen homogénea y elegante. Además, ofrece tejido personalizado bajo pedido.

Gong está disponível em três acabamentos inspirados na natureza – areia, carvão e terracota – com uma estrutura metálica a condizer para uma imagem homogénea e elegante. Oferece também tecido personalizado mediante pedido.



Beige Arena
Bege Areia



Terracota
Terracota



Negro Carbón
Preto Carvão

Posibilidad de modificar la temperatura de color mediante un switch CCT.

A temperatura da cor pode ser alterada através de um switch CCT.



2700K



3000K



4000K

Gong incorpora difusor opal y microprismático que garantiza un control lumínico y el máximo confort visual.

Gong incorpora um difusor opalino e microprismático que garante o controlo lumínico e o máximo conforto visual.



Opal
Opalino



Microprismático
Microprismático



Gong incorpora dos nuevas medidas y ofrece ahora tres tamaños —Ø340, Ø600 y Ø1000 mm— disponibles en versión colgante o plafón.

Gong incorpora duas novas medidas e oferece agora três tamanhos – Ø340, Ø600 e Ø1000 mm – disponíveis nas versões de suspensão ou plafon.

Gong Ø340 Microprisma

| | |
|----------|---------|
| BODY MAT | DIF MAT |
| ST | PMMA |



LED | CRI 92 | W Totals 15

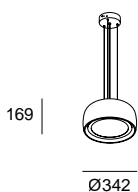

| | K | Real Lm | Ring | Screen | Code |
|---------------------------|------|---------|------|--------|----------------------|
| PHASE CUT 220-240V | 2700 | 1019 | FB | FA | 00-A350-FB-FA |
| | | | W1 | L1 | 00-A350-W1-L1 |
| | | | 60 | EZ | 00-A350-60-EZ |
| DALI-2 / PUSH 220-240V | 2700 | 1019 | FB | FA | 00-A351-FB-FA |
| | | | W1 | L1 | 00-A351-W1-L1 |
| | | | 60 | EZ | 00-A351-60-EZ |
| PHASE CUT 220-240V | 3000 | 1061 | FB | FA | 00-A352-FB-FA |
| | | | W1 | L1 | 00-A352-W1-L1 |
| | | | 60 | EZ | 00-A352-60-EZ |
| DALI-2 / PUSH 220-240V | 3000 | 1061 | FB | FA | 00-A353-FB-FA |
| | | | W1 | L1 | 00-A353-W1-L1 |
| | | | 60 | EZ | 00-A353-60-EZ |
| PHASE CUT 220-240V | 4000 | 1089 | FB | FA | 00-A354-FB-FA |
| | | | W1 | L1 | 00-A354-W1-L1 |
| | | | 60 | EZ | 00-A354-60-EZ |
| DALI-2 / PUSH 220-240V | 4000 | 1089 | FB | FA | 00-A355-FB-FA |
| | | | W1 | L1 | 00-A355-W1-L1 |
| | | | 60 | EZ | 00-A355-60-EZ |

Gong Ø340 Opal

| | |
|----------|---------|
| BODY MAT | DIF MAT |
| ST | PMMA |



LED | CRI 92 | W Totals 15

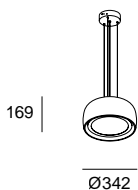

| | K | Real Lm | Ring | Screen | Code |
|---------------------------|------|---------|------|--------|----------------------|
| PHASE CUT 220-240V | 2700 | 658 | FB | FA | 00-A356-FB-FA |
| | | | W1 | L1 | 00-A356-W1-L1 |
| | | | 60 | EZ | 00-A356-60-EZ |
| DALI-2 / PUSH 220-240V | 2700 | 658 | FB | FA | 00-A357-FB-FA |
| | | | W1 | L1 | 00-A357-W1-L1 |
| | | | 60 | EZ | 00-A357-60-EZ |
| PHASE CUT 220-240V | 3000 | 686 | FB | FA | 00-A358-FB-FA |
| | | | W1 | L1 | 00-A358-W1-L1 |
| | | | 60 | EZ | 00-A358-60-EZ |
| DALI-2 / PUSH 220-240V | 3000 | 686 | FB | FA | 00-A359-FB-FA |
| | | | W1 | L1 | 00-A359-W1-L1 |
| | | | 60 | EZ | 00-A359-60-EZ |
| PHASE CUT 220-240V | 4000 | 704 | FB | FA | 00-A360-FB-FA |
| | | | W1 | L1 | 00-A360-W1-L1 |
| | | | 60 | EZ | 00-A360-60-EZ |
| DALI-2 / PUSH 220-240V | 4000 | 704 | FB | FA | 00-A361-FB-FA |
| | | | W1 | L1 | 00-A361-W1-L1 |
| | | | 60 | EZ | 00-A361-60-EZ |

Los acabados y tonalidad mostrados pueden no ser completamente precisos debido a ligeras variaciones en la producción, factores de iluminación fotográficas e impresión.

Os acabamentos e tonalidades apresentados podem não ser totalmente precisos, devido a ligeiras variações na produção, fatores de iluminação fotográfica e de impressão.

| | |
|---------------------------------------|----|
| Gris Seda Cinzento Seda | FB |
| Tejido Crema Tecido Creme | FA |
| Marrón Caoba Castanho Caoba | W1 |
| Terracota jaspeado Terracota jaspeado | L1 |
| Negro Preto | 60 |
| Tejido Negro Tecido Preto | EZ |

Gong Ø600 Microprisma

BODY MAT
ST

DIF MAT
PMMA



LED | CRI 92

231

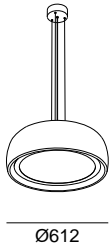

| | K | W Total / Real Lm | Ring | Screen | Code |
|---------------------------|------|-------------------|------|--------|----------------------|
| PHASE CUT 220-240V | 2700 | 27.4W / 1688lm | FB | FA | 00-8902-FB-FA |
| | | | W1 | L1 | 00-8902-W1-L1 |
| | | | 60 | EZ | 00-8902-60-EZ |
| DALI-2 / PUSH 220-240V | 2700 | 28W / 2074lm | FB | FA | 00-A366-FB-FA |
| | | | W1 | L1 | 00-A366-W1-L1 |
| | | | 60 | EZ | 00-A366-60-EZ |
| PHASE CUT 220-240V | 3000 | 27.4W / 1688lm | FB | FA | 00-8933-FB-FA |
| | | | W1 | L1 | 00-8933-W1-L1 |
| | | | 60 | EZ | 00-8933-60-EZ |
| DALI-2 / PUSH 220-240V | 3000 | 28W / 2150lm | FB | FA | 00-A367-FB-FA |
| | | | W1 | L1 | 00-A367-W1-L1 |
| | | | 60 | EZ | 00-A367-60-EZ |
| PHASE CUT 220-240V | 4000 | 27.4W / 1688lm | FB | FA | 00-8953-FB-FA |
| | | | W1 | L1 | 00-8953-W1-L1 |
| | | | 60 | EZ | 00-8953-60-EZ |
| DALI-2 / PUSH 220-240V | 4000 | 28W / 2202lm | FB | FA | 00-A368-FB-FA |
| | | | W1 | L1 | 00-A368-W1-L1 |
| | | | 60 | EZ | 00-A368-60-EZ |

Gong Ø600 Opal

BODY MAT
ST

DIF MAT
PMMA



LED | CRI 92

231

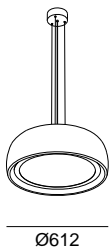

| | K | W Total / Real Lm | Ring | Screen | Code |
|---------------------------|------|-------------------|------|--------|----------------------|
| PHASE CUT 220-240V | 2700 | 27.4W / 1275lm | FB | FA | 00-A294-FB-FA |
| | | | W1 | L1 | 00-A294-W1-L1 |
| | | | 60 | EZ | 00-A294-60-EZ |
| DALI-2 / PUSH 220-240V | 2700 | 28W / 1572lm | FB | FA | 00-A369-FB-FA |
| | | | W1 | L1 | 00-A369-W1-L1 |
| | | | 60 | EZ | 00-A369-60-EZ |
| PHASE CUT 220-240V | 3000 | 27.4W / 1275lm | FB | FA | 00-A295-FB-FA |
| | | | W1 | L1 | 00-A295-W1-L1 |
| | | | 60 | EZ | 00-A295-60-EZ |
| DALI-2 / PUSH 220-240V | 3000 | 28W / 1624lm | FB | FA | 00-A370-FB-FA |
| | | | W1 | L1 | 00-A370-W1-L1 |
| | | | 60 | EZ | 00-A370-60-EZ |
| PHASE CUT 220-240V | 4000 | 27.4W / 1275lm | FB | FA | 00-A296-FB-FA |
| | | | W1 | L1 | 00-A296-W1-L1 |
| | | | 60 | EZ | 00-A296-60-EZ |
| DALI-2 / PUSH 220-240V | 4000 | 28W / 1669lm | FB | FA | 00-A371-FB-FA |
| | | | W1 | L1 | 00-A371-W1-L1 |
| | | | 60 | EZ | 00-A371-60-EZ |

Los acabados y tonalidad mostrados pueden no ser completamente precisos debido a ligeras variaciones en la producción, factores de iluminación fotográficas e impresión.

Os acabamentos e tonalidades apresentados podem não ser totalmente precisos, devido a ligeiras variações na produção, fatores de iluminação fotográfica e de impressão.

Gris Seda Cinzento Seda FB

Tejido Crema Tecido Creme FA

Marrón Caoba Castanho Caoba W1

Terracota jaspeado Terracota jaspeado L1

Negro Preto 60

Tejido Negro Tecido Preto EZ

Gong Ø1000 Microprisma

| | |
|----------|---------|
| BODY MAT | DIF MAT |
| ST | PMMA |

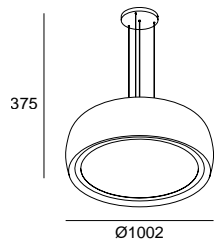

LED | CRI 92 | W Total 38.7

| | K | Real Lm | Ring | Screen | Code |
|---------------------------|------|---------|------|--------|----------------------|
| PHASE CUT 220-240V | 2700 | 3093 | FB | FA | 00-A338-FB-FA |
| | | | W1 | L1 | 00-A338-W1-L1 |
| | | | 60 | EZ | 00-A338-60-EZ |
| DALI-2 / PUSH 220-240V | 2700 | 3093 | FB | FA | 00-A339-FB-FA |
| | | | W1 | L1 | 00-A339-W1-L1 |
| | | | 60 | EZ | 00-A339-60-EZ |
| PHASE CUT 220-240V | 3000 | 3161 | FB | FA | 00-A340-FB-FA |
| | | | W1 | L1 | 00-A340-W1-L1 |
| | | | 60 | EZ | 00-A340-60-EZ |
| DALI-2 / PUSH 220-240V | 3000 | 3161 | FB | FA | 00-A341-FB-FA |
| | | | W1 | L1 | 00-A341-W1-L1 |
| | | | 60 | EZ | 00-A341-60-EZ |
| PHASE CUT 220-240V | 4000 | 3237 | FB | FA | 00-A342-FB-FA |
| | | | W1 | L1 | 00-A342-W1-L1 |
| | | | 60 | EZ | 00-A342-60-EZ |
| DALI-2 / PUSH 220-240V | 4000 | 3237 | FB | FA | 00-A343-FB-FA |
| | | | W1 | L1 | 00-A343-W1-L1 |
| | | | 60 | EZ | 00-A343-60-EZ |

Gong Ø1000 Opal

| | |
|----------|---------|
| BODY MAT | DIF MAT |
| ST | PMMA |

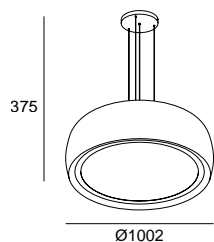

LED | CRI 92 | W Total 38.7

| | K | Real Lm | Ring | Screen | Code |
|---------------------------|------|---------|------|--------|----------------------|
| PHASE CUT 220-240V | 2700 | 2341 | FB | FA | 00-A344-FB-FA |
| | | | W1 | L1 | 00-A344-W1-L1 |
| | | | 60 | EZ | 00-A344-60-EZ |
| DALI-2 / PUSH 220-240V | 2700 | 2341 | FB | FA | 00-A345-FB-FA |
| | | | W1 | L1 | 00-A345-W1-L1 |
| | | | 60 | EZ | 00-A345-60-EZ |
| PHASE CUT 220-240V | 3000 | 2394 | FB | FA | 00-A346-FB-FA |
| | | | W1 | L1 | 00-A346-W1-L1 |
| | | | 60 | EZ | 00-A346-60-EZ |
| DALI-2 / PUSH 220-240V | 3000 | 2394 | FB | FA | 00-A347-FB-FA |
| | | | W1 | L1 | 00-A347-W1-L1 |
| | | | 60 | EZ | 00-A347-60-EZ |
| PHASE CUT 220-240V | 4000 | 2454 | FB | FA | 00-A348-FB-FA |
| | | | W1 | L1 | 00-A348-W1-L1 |
| | | | 60 | EZ | 00-A348-60-EZ |
| DALI-2 / PUSH 220-240V | 4000 | 2454 | FB | FA | 00-A349-FB-FA |
| | | | W1 | L1 | 00-A349-W1-L1 |
| | | | 60 | EZ | 00-A349-60-EZ |

Los acabados y tonalidad mostrados pueden no ser completamente precisos debido a ligeras variaciones en la producción, factores de iluminación fotográficas e impresión.

Os acabamentos e tonalidades apresentados podem não ser totalmente precisos, devido a ligeiras variações na produção, fatores de iluminação fotográfica e de impressão.

| | | |
|---------------------------------------|----|--|
| Gris Seda Cinzento Seda | FB | |
| Tejido Crema Tecido Creme | FA | |
| Marrón Caoba Castanho Caoba | W1 | |
| Terracota jaspeado Terracota jaspeado | L1 | |
| Negro Preto | 60 | |
| Tejido Negro Tecido Preto | EZ | |

COCO



Performance Universe



La luminaria más grácil

Las esferas de luz difusa de Coco descansan en estructuras metálicas que crean una agradable combinación y proporcionan una luz ambiental adecuada para crear escenas relajantes.

A luminária mais grácil

As esferas de luz difusa de Coco assentam em estruturas metálicas que criam uma combinação agradável e proporcionam uma luz ambiente adequada para criar cenas relaxantes.







El chandelier permite elegir la posición de los brazos.

O chandelier permite escolher a posição dos braços.

Coco Single

QS

| | |
|----------|---------|
| BODY MAT | DIF MAT |
| ST,AL | PC |

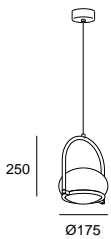

E14 | W Max. 9

Negro Preto 05 ●
Oro pintado Ouro pintado ET ●
Blanco opal Branco opalino M1 ○

Structure Difussor

05 ● M1 ○
ET ● M1 ○

Code

00-7984-05-M1
00-7984-ET-M1

Coco Double

QS

| | |
|----------|---------|
| BODY MAT | DIF MAT |
| ST,AL | PC |

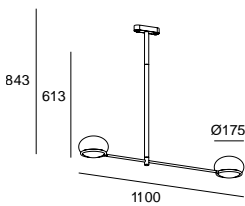

E14 | W 2 × Max. 9

Negro Preto 05 ●
Blanco opal Branco opalino M1 ○

Structure Difussor

05 ● M1 ○

Code

00-9003-05-M1

Coco Chandelier

QS

| | |
|----------|---------|
| BODY MAT | DIF MAT |
| ST,AL | PC |

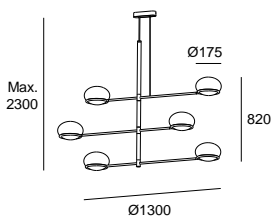

E14 | W 6 × Max. 9

Negro Preto 05 ●
Blanco opal Branco opalino M1 ○

Structure Difussor

05 ● M1 ○

Code

00-7986-05-M1

Shoemaker



Performance Universe



Silenciosa calidez

Joel Karlsson reinterpreta con Shoemaker una forma clásica, dibujando con líneas rectas y puras una pieza muy técnica a la vez que decorativa. El acabado en fieltro reciclado del difusor en las dos opciones disponibles, es un factor determinante en la personalidad de la colección, que se presenta además con distintas temperaturas de color y otras ventajas de la iluminación inteligente.

Silenciosa calidez

Joel Karlsson reinterpreta com Shoemaker uma forma clássica, criando com linhas retas e puras uma peça bastante técnica mas também decorativa. O acabamento em feltro reciclado do difusor nas duas opções disponíveis é um fator determinante na personalidade da coleção, que se apresenta também com diferentes temperaturas de cor e outras vantagens da iluminação inteligente.





Tecnología Tunable White (2700K – 6000K)

Shoemaker integra tecnología Tunable White, que permite ajustar la temperatura de color entre 2700K y 6000K, adaptando la luz al ritmo biológico, al momento del día o al tipo de actividad. Desde tonos cálidos y acogedores hasta blancos fríos y energizantes, ofrece flexibilidad y bienestar en entornos profesionales, comerciales o residenciales.

Tecnologia Tunable White (2700 K - 6000 K)

Shoemaker integra tecnologia Tunable White, que permite ajustar a temperatura da cor entre 2700 K e 6000 K, adaptando a luz ao ritmo biológico, à hora do dia ou ao tipo de atividade. Dos tons quentes e acolhedores aos brancos frios e energizantes, oferece flexibilidade e bem-estar em ambientes profissionais, comerciais ou residenciais.

Shoemaker Ø669

| | |
|----------|---------|
| BODY MAT | DIF MAT |
| ST,FELT | PMMA |

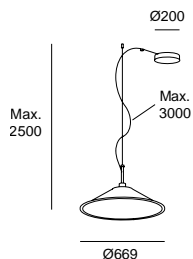

LED | CRI 92

| | K | W Total | Real Lm | Structure | Body | Code |
|---------------------------|--------------|---------|---------|-----------|------|----------------------|
| 0-10V 100-240V | 2700 | 28.6 | 1494 | 05 ● | EK ● | 00-7728-05-EK |
| | | | | 05 ● | EQ ● | 00-7728-05-EQ |
| DALI-2 100-240V | 2700 | 28.6 | 1494 | 05 ● | EK ● | 00-7731-05-EK |
| | | | | 05 ● | EQ ● | 00-7731-05-EQ |
| DALI DT8 220-240V (TW) | TW 2700-6500 | 22.2 | 1197 | 05 ● | EK ● | 00-7727-05-EK |
| | | | | 05 ● | EQ ● | 00-7727-05-EQ |

Negro Preto 05 ●
 Gris oscuro Cinza escuro EK ●
 Gris antracita Cinza antracito EQ ●

Shoemaker 1204mm

| | |
|----------|---------|
| BODY MAT | DIF MAT |
| ST,FELT | PMMA |

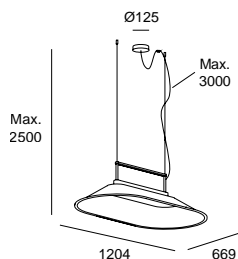

LED | CRI 92

| | K | W Total | Real Lm | Structure | Body | Code |
|---------------------------|--------------|---------|---------|-----------|------|----------------------|
| 0-10V 100-240V | 2700 | 55 | 3631 | 05 ● | EK ● | 00-7730-05-EK |
| | | | | 05 ● | EQ ● | 00-7730-05-EQ |
| DALI-2 100-240V | 2700 | 55 | 3631 | 05 ● | EK ● | 00-7732-05-EK |
| | | | | 05 ● | EQ ● | 00-7732-05-EQ |
| DALI DT8 220-240V (TW) | TW 2700-6500 | 53.9 | 4002 | 05 ● | EK ● | 00-7729-05-EK |
| | | | | 05 ● | EQ ● | 00-7729-05-EQ |

Negro Preto 05 ●
 Gris oscuro Cinza escuro EK ●
 Gris antracita Cinza antracito EQ ●

80 0-20 mm

Material técnico y sostenible

El panel está fabricado con material reciclado, fonoabsorbente y con propiedades ignífugas, lo que lo convierte en una solución ideal para espacios donde el confort acústico y la seguridad son prioritarios.

Material técnico e sustentável

O painel é fabricado em material reciclado, fonoabsorvente e com propriedades ignífugas, o que o torna uma solução ideal para espaços onde o conforto acústico e a segurança são uma prioridade.



Acabado gris oscuro (EK)
Acabamento cinzento-escuro (EK).



Acabado gris antracita (EQ)
Acabamento cinzento antracite (EQ).

Veneto



Performance Universe



P. 298



Delicadeza atemporal

Veneto es una luminaria con un diseño clásico actual. Tanto la ligereza del difusor de metacrilato como el detalle en dorado de la pieza, le confieren una personalidad propia equilibrando su puesta en escena. Veneto ofrece una iluminación difusa y delicada, cálida e íntima, tanto en su versión individual como múltiple.

Delicadeza intemporal

Veneto é uma luminária com um design clássico atual. Tanto a leveza do difusor de metacrilato como o detalhe dourado da peça conferem a esta uma personalidade própria, equilibrando a sua encenação. Veneto oferece uma iluminação difusa e delicada, quente e íntima, tanto na sua versão individual como múltipla.

Difusor de metacrilato.
Difusor de metraquilato.



Veneto Surfaced 1 Body

| | | |
|----------|---------|--|
| BODY MAT | DIF MAT | |
| ST.AL | PMMA | |

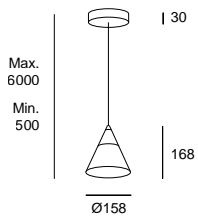

LED | K 2700 | CRI 80 | W Total 8.3 | Real Lm 452

Blanco Branco 14
Latón pulido Latão polido DO

| | Canopy | Body | Code |
|--------------------|--------------------------|-------------------------------------|--------------------------------|
| ON-OFF 220-240V | 14 <input type="radio"/> | DO <input checked="" type="radio"/> | 00-A019-14-DO QS |
| PHASE CUT 220-240V | 14 <input type="radio"/> | DO <input checked="" type="radio"/> | 00-7589-14-DO |

Acabados The Colours bajo pedido mínimo de 15 unidades. Consultar precios en tarifa y plazos de entrega con equipo comercial.
Acabamentos The Colours sujeitos a encomenda mínima de 15 unidades. Consultar preços e prazos de entrega com a nossa equipa comercial.

Canopy: DL Oro Ouro **Body:** DO Latón pulido Latão polido
 60 Negro Preto DO Latón pulido Latão polido

QS Quick Service | 2-6 días laborables (tiempo de transporte no incluido)
Quick Service | 2-6 dias úteis (tempo de transporte não incluido)

Veneto Recessed 1 Body

| | | |
|----------|---------|--|
| BODY MAT | DIF MAT | |
| ST.AL | PMMA | |

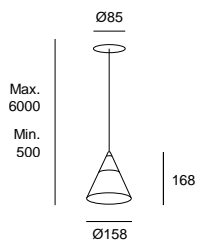

LED | K 2700 | CRI 80 | W Total 8.3 | Real Lm 452

Blanco Branco 14
Latón pulido Latão polido DO

| | Canopy | Body | Code |
|--------------------|--------------------------|-------------------------------------|----------------------|
| ON-OFF 220-240V | 14 <input type="radio"/> | DO <input checked="" type="radio"/> | 00-A020-14-DO |
| PHASE CUT 220-240V | 14 <input type="radio"/> | DO <input checked="" type="radio"/> | 00-7591-14-DO |

65 0-30 mm

Nimes



Performance Universe



Un clásico atemporal

Un clásico que nunca falla. Nimes es un óvalo opal sencillo y funcional.

Um clássico intemporal

Um clássico que nunca falha. Nimes é um óvalo opal simples e funcional.

Nimes

QS

| | | |
|----------|---------|--|
| BODY MAT | DIF MAT | |
| ST | GLA | |

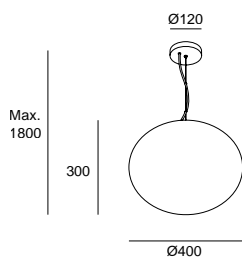

E27 | W Max. 15

Canopy Difusor

14 F9

*Bombilla no incluida.
*Lâmpada não incluida.

Blanco Branco 14
Arenado Areado F9

Code

00-9032-14-F9



Noway



Performance Universe



P. 256



Simplicidad y pureza

Noway combina a partes iguales simplicidad, pureza y autenticidad. La combinación de dos estructuras difusoras de distintos tamaños, en acabados negro mate y dorado, ofrecen una iluminación cálida y confortable.

Simplicidade e pureza

Noway combina simplicidade, pureza e autenticidade em partes iguais. A combinação de duas estruturas difusoras de tamanhos diferentes, em acabamentos preto mate e dourado, oferecem uma iluminação quente e confortável.

Cuenta con un switch para elegir la temperatura adecuada.
Possui um switch para escolher a temperatura adequada.



La pantalla del nivel inferior siempre es en acabado negro.
O quebra-luz do nível inferior sempre em acabamento preto.

Noway Small

QS

| | |
|----------|----------------|
| BODY MAT | SWITCH CCT |
| ST | 2700-3000-4000 |

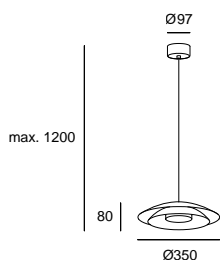

LED | K 2700-3000-4000 | CRI 92 | W Total 18.5 | Real Lm 618 (3000K)

Negro Preto 05 ●
Oro mate Ouro mate DN ●



Upper Screen Lower Screen Code

PHASE CUT 220-240V

05 ●
DN ●

05 ●
05 ●

00-8392-05-05

00-8392-DN-05

Noway Big

QS

| | |
|----------|----------------|
| BODY MAT | SWITCH CCT |
| ST | 2700-3000-4000 |

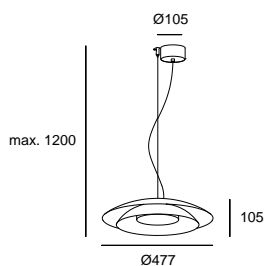

LED | K 2700-3000-4000 | CRI 92 | W Total 24.5 | Real Lm 813 (3000K)

Negro Preto 05 ●
Oro mate Ouro mate DN ●



Upper Screen Lower Screen Code

PHASE CUT 220-240V

05 ●
DN ●

05 ●
05 ●

00-8395-05-05

00-8395-DN-05

Florón negro
Florão preta

Keops



Essential Universe



Personalización y carácter

Keops es una colección de colgantes muy funcionales que usan bombilla. Este diseño tiene la clara intención de jugar con el color y sus diferentes medidas. Tiene unas geometrías sencillas y versátiles, donde destacan pequeños detalles como sus ranuras superiores que crean un juego de luz y sobras muy característico de este diseño. Además, es una luminaria que permite jugar de manera amplísima con el color de cada nivel ya que se puede personalizar cada uno con el RAL deseado.

Personalização e caráter

Keops é uma coleção de suspensos muito funcionais que utilizam lâmpada. Este design tem a clara intenção de brincar com a cor e as suas diferentes medidas. Apresenta geometrias simples e versáteis, onde se destacam pequenos pormenores como as suas ranhuras superiores que criam um jogo de luz e sombra muito característico deste design. Para além disso, é uma luminária que permite combinar de forma ampla com a cor de cada nível, uma vez que cada um pode ser personalizado com o RAL desejado.

Configura tu Keops Configure a sua Keops

Configurador para personalización disponible.
Configurador para personalização disponível.

keops.ledsc4.com



Acabados personalizables bajo petición mediante configurador.
Acabamentos personalizáveis sob pedido através do configurador.



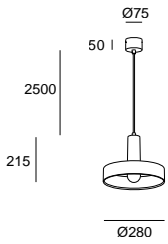
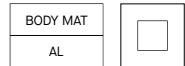

Keops Individual

QS



E27 | W Max. 15

Blanco grisáceo Branco cinzento A1 
 Gris parduzco Castanho acinzentado A3 
 Rojo ladrillo Tijolo vermelho A4 

| Canopy | Level 1 | Level 2 | Code |
|--|--|--|----------------------|
| A1  | A1  | A1  | 00-9033-A1-A1 |
| A3  | A3  | A3  | 00-9033-A3-A1 |
| A4  | A4  | A4  | 00-9033-A4-A1 |



*Bombilla no incluida.
 *Lâmpada não incluida.

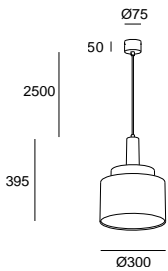
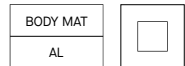

Keops Triple Ø300

QS



E27 | W Max. 15

Blanco grisáceo Branco cinzento A1 
 Gris parduzco Castanho acinzentado A3 
 Rojo ladrillo Tijolo vermelho A4 

| Canopy | Level 1 | Level 2 | Level 3 | Code |
|--|--|--|--|----------------------|
| A4  | A4  | A3  | A1  | 00-9035-CV-A1 |



*Bombilla no incluida.
 *Lâmpada não incluida.

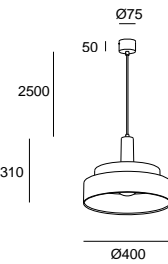
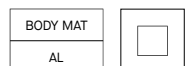

Keops Triple Ø400

QS



E27 Globe Max. Ø120 mm | W Max. 15

Blanco grisáceo Branco cinzento A1 
 Gris parduzco Castanho acinzentado A3 
 Rojo ladrillo Tijolo vermelho A4 

| Canopy | Level 1 | Level 2 | Level 3 | Code |
|--|--|--|--|----------------------|
| A3  | A3  | A1  | A4  | 00-9034-CV-A1 |



*Bombilla no incluida.
 *Lâmpada não incluida.

Keops Triple Ø500

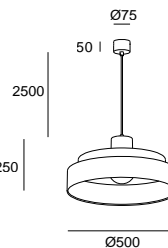
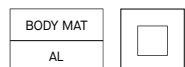
QS



E27 | W Max. 15

Blanco grisáceo Branco cinzento A1 
 Gris parduzco Castanho acinzentado A3 
 Rojo ladrillo Tijolo vermelho A4 

| Canopy | Level 1 | Level 2 | Level 3 | Code |
|--|--|--|--|----------------------|
| A1  | A1  | A4  | A3  | 00-9036-CV-A1 |

*Bombilla no incluida.
 *Lâmpada não incluida.

Attic



Performance Universe



P. 300



Riqueza compositiva

Attic es un sistema de iluminación extremadamente funcional gracias a la gran facilidad de instalación y adición de luminarias. La luz de sus bombillas puede plantearse tanto para zonas de trabajo como para crear ambientes relajados. Además, el efecto lumínico que generan las aperturas laterales de la pantalla proporciona una integración total de la estructura del cableado en la composición final de la pieza. Con posibilidad de personalización del color de las pantallas y tres formas geométricas combinables entre ellas, Attic es una pieza modular en todos los sentidos.

Riqueza compositiva

O Attic é um sistema de iluminação extremamente funcional graças à grande facilidade de instalação e de adição de luminárias. A luz das suas lâmpadas pode ser utilizada tanto para zonas de trabalho como para criar ambientes descontraídos. Além disso, o efeito lumínico gerado pelas aberturas laterais do abajur permite uma integração total da estrutura de cablagem na composição final da peça. Com a possibilidade de personalizar a cor dos abajures e três formas geométricas combináveis entre si, Attic é uma peça modular em todos os sentidos.



Configura tu Attic

Configure a sua Attic

Configurador para personalización disponible.
 Configurador para personalização disponível.

attic.ledsc4.com



1 Instalación

Installation

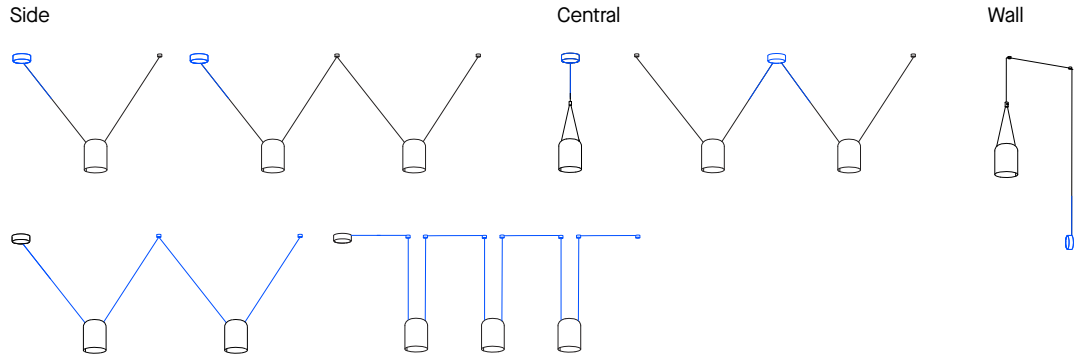

Con 2 opciones de instalación
 Con 2 opções de instalação

No hay opciones de instalación para el modelo individual con florón central.
 Não disponível para o modelo individual com roseta central.

2 Longitud de cable

Comprimento do cabo

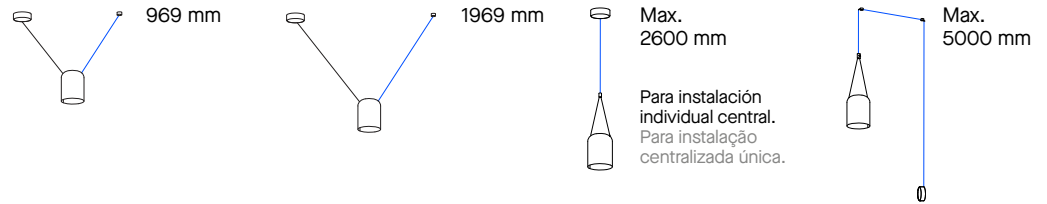

3 Pantalla

Quebra-luz



4 Combinaciones estandar

Combinações standard

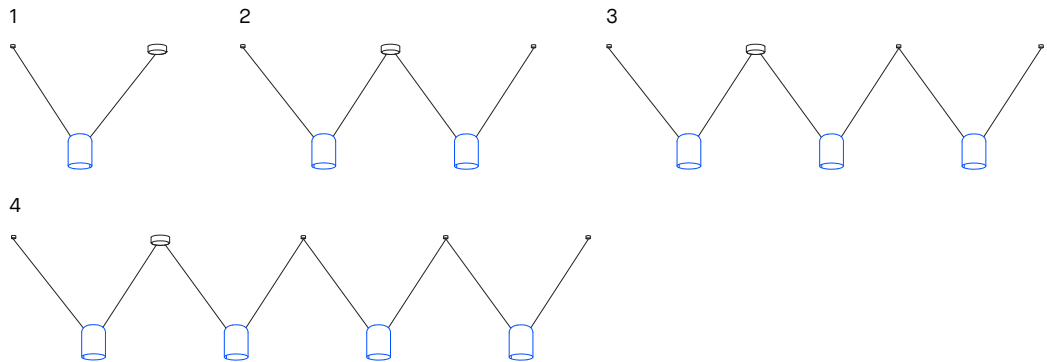

Más opciones a través del configurador.
 Mais opções através do configurador.

5 Acabados

Acabamentos

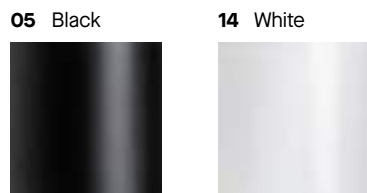

Múltiples colores personalizables bajo petición.
 Várias cores personalizáveis a pedido.



Los enganches al techo permiten las dos opciones de instalación.

Os suportes do teto permitem as duas opções de instalação.



Attic Rectangular Shape

QS

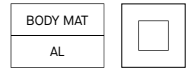

E27 | W Max. 15

 Blanco Branco 14
 Negro Preto 05

| Structure | Exterior Screen | Code |
|--|---|--|
| 05 <input checked="" type="radio"/> 05 <input checked="" type="radio"/> | 05 <input checked="" type="radio"/> 14 <input type="radio"/> | 00-7388-05-05 00-7388-05-14 |
| 05 <input checked="" type="radio"/> 05 <input checked="" type="radio"/> | 05 <input checked="" type="radio"/> 14 <input type="radio"/> | 00-7389-05-05 00-7389-05-14 |
| 05 <input checked="" type="radio"/> 05 <input checked="" type="radio"/> | 05 <input checked="" type="radio"/> 14 <input type="radio"/> | 00-9007-05-05 00-9007-05-14 |

 *Bombilla no incluida.
 *Lâmpada não incluida.
Attic Rectangular Shape V
1200 mm

QS

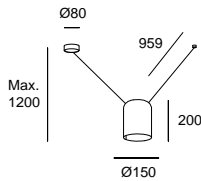
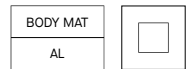

E27 | W Max. 15

 Blanco Branco 14
 Negro Preto 05

| Structure | Exterior Screen | Code |
|--|---|--|
| 05 <input checked="" type="radio"/> 05 <input checked="" type="radio"/> | 05 <input checked="" type="radio"/> 14 <input type="radio"/> | 00-7392-05-05 00-7392-05-14 |
| 05 <input checked="" type="radio"/> 05 <input checked="" type="radio"/> | 05 <input checked="" type="radio"/> 14 <input type="radio"/> | 00-7393-05-05 00-7393-05-14 |
| 05 <input checked="" type="radio"/> 05 <input checked="" type="radio"/> | 05 <input checked="" type="radio"/> 14 <input type="radio"/> | 00-9042-05-05 00-9042-05-14 |

 *Bombilla no incluida.
 *Lâmpada não incluida.
Attic Rectangular Shape V
2200 mm

QS

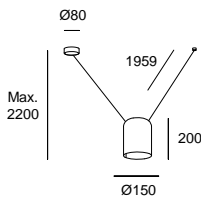
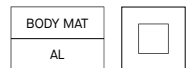

E27 | W Max. 15

 Blanco Branco 14
 Negro Preto 05

| Structure | Exterior Screen | Code |
|--|---|--|
| 05 <input checked="" type="radio"/> 05 <input checked="" type="radio"/> | 05 <input checked="" type="radio"/> 14 <input type="radio"/> | 00-7390-05-05 00-7390-05-14 |
| 05 <input checked="" type="radio"/> 05 <input checked="" type="radio"/> | 05 <input checked="" type="radio"/> 14 <input type="radio"/> | 00-7391-05-05 00-7391-05-14 |
| 05 <input checked="" type="radio"/> 05 <input checked="" type="radio"/> | 05 <input checked="" type="radio"/> 14 <input type="radio"/> | 00-9043-05-05 00-9043-05-14 |

 *Bombilla no incluida.
 *Lâmpada não incluida.

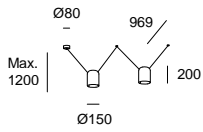
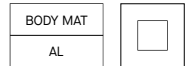

Attic 2 bodies Rectangular Shape 1200mm Side

QS



E27 | W 2 × Max. 15

Blanco Branco 14
Negro Preto 05

| Structure | Exterior Screen | Code |
|--|---|--|
|  05 <input checked="" type="radio"/> 05 <input checked="" type="radio"/> | 05 <input checked="" type="radio"/> 14 <input type="radio"/> | 00-7396-05-05 00-7396-05-14 |
|  05 <input checked="" type="radio"/> 05 <input checked="" type="radio"/> | 05 <input checked="" type="radio"/> 14 <input type="radio"/> | 00-7397-05-05 00-7397-05-14 |
|  05 <input checked="" type="radio"/> 05 <input checked="" type="radio"/> | 05 <input checked="" type="radio"/> 14 <input type="radio"/> | 00-9044-05-05 00-9044-05-14 |

*Bombilla no incluída.
*Lâmpada não incluída.

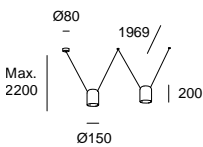
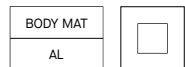

Attic 2 bodies Rectangular Shape 2200 mm Side

QS



E27 | W 2 × Max. 15

Blanco Branco 14
Negro Preto 05

| Structure | Exterior Screen | Code |
|--|---|--|
|  05 <input checked="" type="radio"/> 05 <input checked="" type="radio"/> | 05 <input checked="" type="radio"/> 14 <input type="radio"/> | 00-7394-05-05 00-7394-05-14 |
|  05 <input checked="" type="radio"/> 05 <input checked="" type="radio"/> | 05 <input checked="" type="radio"/> 14 <input type="radio"/> | 00-7395-05-05 00-7395-05-14 |
|  05 <input checked="" type="radio"/> 05 <input checked="" type="radio"/> | 05 <input checked="" type="radio"/> 14 <input type="radio"/> | 00-9045-05-05 00-9045-05-14 |

*Bombilla no incluída.
*Lâmpada não incluída.

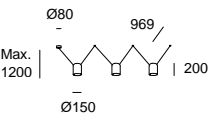
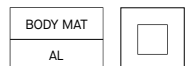

Attic 3 bodies Rectangular Shape 1200mm Side

QS



E27 | W 3 × Max. 15

Blanco Branco 14
Negro Preto 05

| Structure | Exterior Screen | Code |
|--|---|--|
|  05 <input checked="" type="radio"/> 05 <input checked="" type="radio"/> | 05 <input checked="" type="radio"/> 14 <input type="radio"/> | 00-7400-05-05 00-7400-05-14 |
|  05 <input checked="" type="radio"/> 05 <input checked="" type="radio"/> | 05 <input checked="" type="radio"/> 14 <input type="radio"/> | 00-7401-05-05 00-7401-05-14 |
|  05 <input checked="" type="radio"/> 05 <input checked="" type="radio"/> | 05 <input checked="" type="radio"/> 14 <input type="radio"/> | 00-9046-05-05 00-9046-05-14 |

*Bombilla no incluída.
*Lâmpada não incluída.

Attic 3 bodies Rectangular Shape 2200mm Side

QS

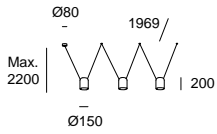
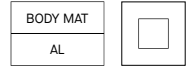

E27 | W 3 × Max. 15

Blanco Branco 14 ○
Negro Preto 05 ●

| Structure | Exterior Screen | Code |
|--------------|-----------------|--------------------------------|
| 05 ● 05 ● | 05 ● 14 ○ | 00-7398-05-05 00-7398-05-14 |
| 05 ● 05 ● | 05 ● 14 ○ | 00-7399-05-05 00-7399-05-14 |
| 05 ● 05 ● | 05 ● 14 ○ | 00-9047-05-05 00-9047-05-14 |

*Bombilla no incluida.
*Lâmpada não incluida.

Attic 4 bodies Rectangular Shape 1200mm Side

QS

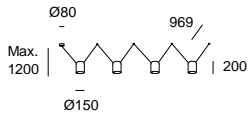
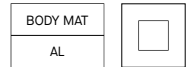

E27 | W 4 × Max. 15

Blanco Branco 14 ○
Negro Preto 05 ●

| Structure | Exterior Screen | Code |
|--------------|-----------------|--------------------------------|
| 05 ● 05 ● | 05 ● 14 ○ | 00-7404-05-05 00-7404-05-14 |
| 05 ● 05 ● | 05 ● 14 ○ | 00-7405-05-05 00-7405-05-14 |
| 05 ● 05 ● | 05 ● 14 ○ | 00-9048-05-05 00-9048-05-14 |

*Bombilla no incluida.
*Lâmpada não incluida.

Attic 4 bodies Rectangular Shape 2200mm Side

QS

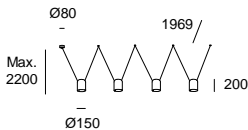
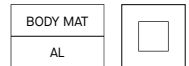

E27 | W 4 × Max. 15

Blanco Branco 14 ○
Negro Preto 05 ●

| Structure | Exterior Screen | Code |
|--------------|-----------------|--------------------------------|
| 05 ● 05 ● | 05 ● 14 ○ | 00-7402-05-05 00-7402-05-14 |
| 05 ● 05 ● | 05 ● 14 ○ | 00-7403-05-05 00-7403-05-14 |
| 05 ● 05 ● | 05 ● 14 ○ | 00-9049-05-05 00-9049-05-14 |

*Bombilla no incluida.
*Lâmpada não incluida.

Super Attic



Performance Universe



P. 304



Presencia contundente y armónica

La colección modular Attic se amplía con la llegada de la mayor de la familia: una pantalla cónica de gran tamaño que se adueña sin complejos del espacio dotándolo de presencia y gusto por los detalles. Puede personalizarse el color en cualquier RAL bajo petición.

Presença forte e harmoniosa

A coleção modular Attic é ampliada com a chegada do maior da família: um quebra-luz cónico de grande dimensão que toma conta do espaço sem complexos, dotando-o de presença e gosto pelos detalhes. A cor pode ser personalizada em qualquer RAL, sob pedido.

Configura tu Attic

Configure a sua Attic

Configurador para personalización disponible.
Configurador para personalização disponível.

attic.ledsc4.com



1 Instalación

Installation

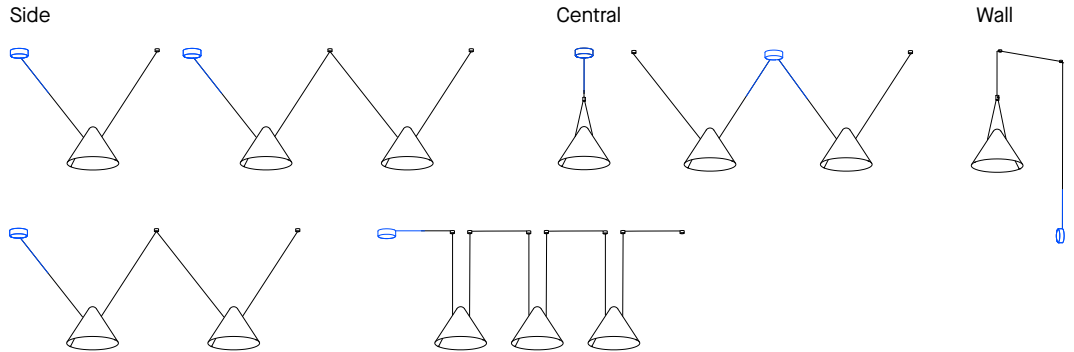

Con 2 opciones de instalación
Con 2 opções de instalação

No hay opciones de instalación para el modelo individual con florón central.
Não disponível para o modelo individual com roseta central.

2 Longitud de cable

Comprimento do cabo

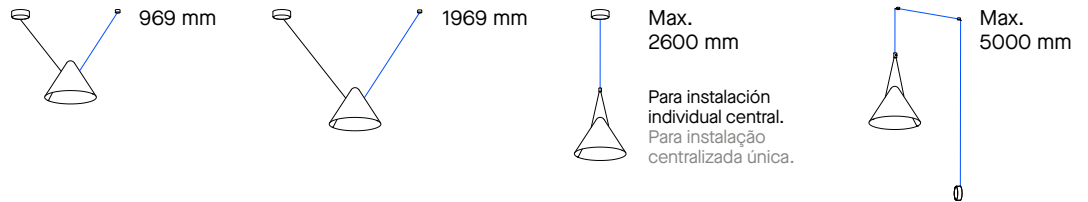

3 Combinaciones estandar

Combinações standard

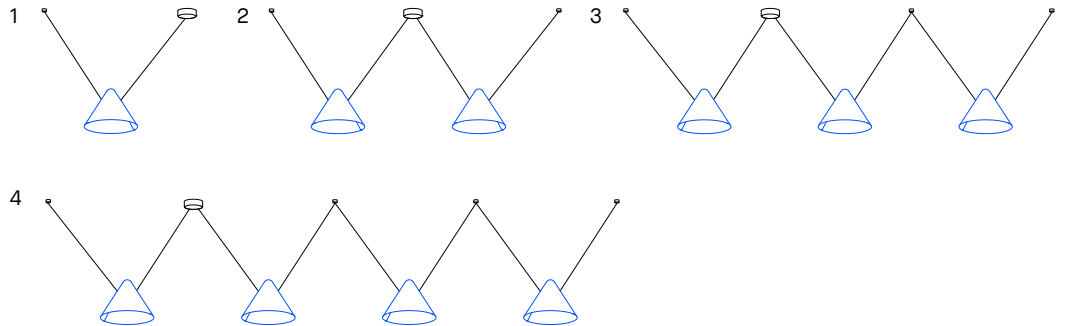

Más opciones a través del configurador.
Mais opções através do configurador.

4 Acabados

Acabamentos

05 Black



Múltiples colores personalizables bajo petición.
Várias cores personalizáveis a pedido.

Super Attic

QS

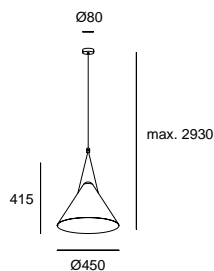
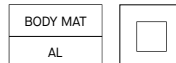

E27 | W Max. 15

Negro Preto 05 ●

Structure Exterior Screen

Code

05 ●

05 ●

00-8348-05-05

*Bombilla no incluída.
*Lâmpada não incluída.

Super Attic Shape V 1250mm

QS

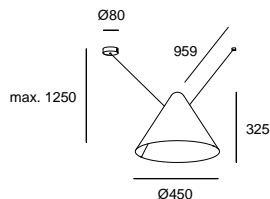
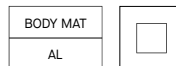

E27 | W Max. 15

Negro Preto 05 ●

Structure Exterior Screen

Code

05 ●

05 ●

00-8365-05-05

*Bombilla no incluída.
*Lâmpada não incluída.

Super Attic Shape V 2250mm

QS

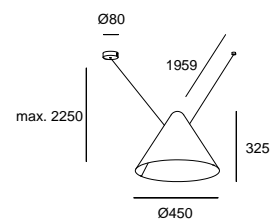
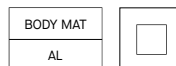

E27 | W Max. 15

Negro Preto 05 ●

Structure Exterior Screen

Code

05 ●

05 ●

00-8364-05-05

*Bombilla no incluída.
*Lâmpada não incluída.

Super Attic 2 bodies 1250mm Side

QS

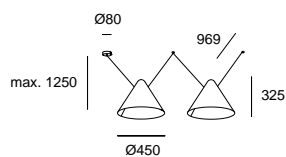
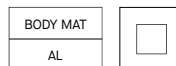

E27 | W 2 × Max. 15

Negro Preto 05 ●

Structure Exterior Screen

Code

05 ●

05 ●

00-8373-05-05

*Bombilla no incluída.
*Lâmpada não incluída.

Super Attic 2 bodies 2250mm Side

QS

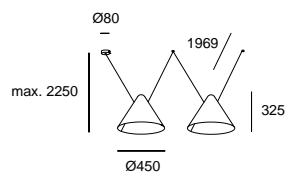
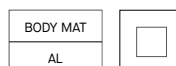

E27 | W 2 × Max. 15

Negro Preto 05 ●

Structure Exterior Screen

Code

05 ●

05 ●

00-8369-05-05

*Bombilla no incluída.
*Lâmpada não incluída.

Super Attic 3 bodies 1250mm Side

QS

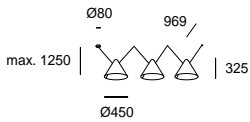

E27 | W 3 × Max. 15

BODY MAT
AL



Negro Preto 05 ●

| Structure | Exterior Screen | Code |
|-----------|-----------------|---------------|
| 05 ● | 05 ● | 00-8381-05-05 |

*Bombilla no incluída.
*Lâmpada não incluída.

Super Attic 3 bodies 2250mm Side

QS

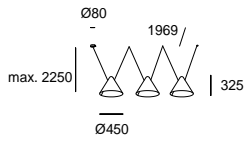

E27 | W 3 × Max. 15

BODY MAT
AL



Negro Preto 05 ●

| Structure | Exterior Screen | Code |
|-----------|-----------------|---------------|
| 05 ● | 05 ● | 00-8377-05-05 |

*Bombilla no incluída.
*Lâmpada não incluída.

Super Attic 4 Bodies 1250mm Side

QS

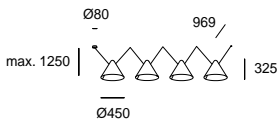

E27 | W 4 × Max. 15

BODY MAT
AL



Negro Preto 05 ●

| Structure | Code |
|-----------|---------------|
| 05 ● | 00-8389-05-05 |

*Bombilla no incluída.
*Lâmpada não incluída.

Super Attic 4 Bodies 2250mm Side

QS

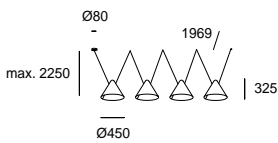

E27 | W 4 × Max. 15

BODY MAT
AL



Negro Preto 05 ●

| Structure | Code |
|-----------|---------------|
| 05 ● | 00-8385-05-05 |

*Bombilla no incluída.
*Lâmpada não incluída.

H



Performance Universe



P. 216



P. 258



P. 306

**Distinción natural**

De líneas simples y puras, H es una reinterpretación de la clásica pantalla donde el valor añadido es la confortabilidad de su luz. Ofrece tanto una luz funcional para trabajo, como al mismo tiempo, crea un delicado halo adicional gracias a la forma abierta y levemente hundida de la tija superior, creando un agradable juego de luces y sombras.

Distinção natural

De linhas simples e puras, H é uma reinterpretação do abajur clássico onde a mais-valia é o conforto da sua luz. Oferece tanto uma luz de trabalho funcional como cria uma auréola adicional delicada graças à forma aberta e ligeiramente afundada do espigão superior, criando um agradável jogo de luz e sombra.





Detalle del sutil efecto de luz superior.
Pormenor do subtil efeito de luz superior.

H Pendant Surface

| | | |
|----------|---------|---|
| BODY MAT | DIF MAT | □ |
| ST | ACR | |

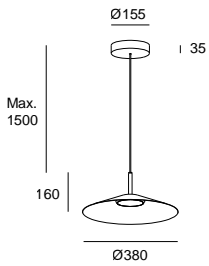

LED | K 2700 | CRI 90 | W Total 277 | Real Lm 1328

Negro Preto 05 ●
Oro mate Ouro mate DN ●

| | Structure | Code |
|-----------------|-----------|-------------------------|
| ON-OFF 220-240V | 05 ● | 00-7742-05-05 QS |
| | DN ● | 00-7742-DN-DN QS |
| DALI-2 220-240V | 05 ● | 00-9050-05-05 |
| | DN ● | 00-9050-DN-DN |

H Pendant Recessed

| | | |
|----------|---------|---|
| BODY MAT | DIF MAT | □ |
| ST | ACR | |

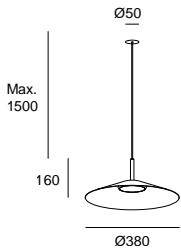

LED | K 2700 | CRI 90 | W Total 277 | Real Lm 1328

Negro Preto 05 ●
Oro mate Ouro mate DN ●

| | Body | Code |
|-----------------|------|----------------------|
| ON-OFF 220-240V | 05 ● | 00-9052-05-05 |
| | DN ● | 00-9052-DN-DN |
| DALI-2 220-240V | 05 ● | 00-9053-05-05 |
| | DN ● | 00-9053-DN-DN |

Florón negro
Florão preta

Napa



Essential Universe



Diseño versátil

Napa es una pieza atemporal, neutra y de líneas suaves. El punto de luz que se insinúa en el vértice superior le confiere una elegancia particular. Sola o en composición, Napa proporciona una iluminación práctica y funcional capaz de armonizar cualquier espacio.

Design versátil

Napa é uma peça intemporal, neutra e de linhas suaves. O ponto de luz que se insinua no vértice superior confere-lhe uma elegância particular. Sozinha ou em composição, Napa proporciona uma iluminação prática e funcional capaz de harmonizar qualquer espaço.

Distintas combinaciones de acabados para la pantalla y sus detalles.

Diferentes combinações de acabamentos para o quebra-luz e os seus detalhes.



05-05



05-DN



Florón negro
Florão preta

Napa Small

QS

BODY MAT
ST

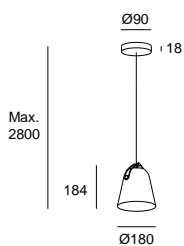

E27 | W Max. 15

Negro Preto 05 ●
Oro mate Ouro mate DN ●

Body

Button

Code

05 ●
05 ●

05 ●
DN ●

00-7992-05-05
00-7992-05-DN

*Bombilla no incluida.
*Lâmpada não incluída.

Napa Big

QS

BODY MAT
ST

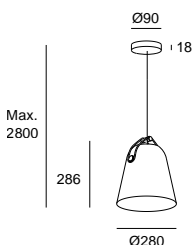

E27 | W Max. 15

Negro Preto 05 ●
Oro mate Ouro mate DN ●

Body

Button

Code

05 ●
05 ●

05 ●
DN ●

00-7993-05-05
00-7993-05-DN

*Bombilla no incluida.
*Lâmpada não incluída.

Candle



Performance Universe



Reinterpretación de un clásico

Esta delicada luminaria es la reinterpretación contemporánea de la clásica vela. La luz está trabajada respetando la esencia de esta inspiración, ofreciendo calidez y armonía. Desde la simplicidad de la pieza inicial hasta la complejidad compositiva del chandelier, Candle se ha transformado en una colección viva que cambia sustancialmente con la incorporación de sus dos accesorios, el disco y esfera. Formas esenciales que mantienen la delicadeza inicial de la colección.

Reinterpretação de um clássico

Esta delicada luminária é a reinterpretação contemporânea de uma clássica vela. A luz é trabalhada respeitando a essência desta inspiração, oferecendo calidez e harmonia. Da simplicidade da peça inicial à complexidade compositiva do chandelier, Candle transformou-se numa coleção viva que muda substancialmente com a incorporação dos seus dois acessórios, o disco e a esfera. Formas essenciais que mantêm a delicadeza inicial da coleção.



Candle 1 Body Surface

QS

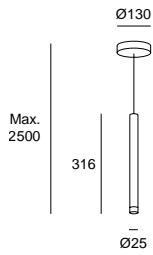

LED | K 2700 | CRI 90 | W Total 4.1 | Real Lm 154



ON-OFF 100-240V

Body

Code

27 ●
60 ●00-6017-27-27
00-6017-60-60

| |
|----------|
| BODY MAT |
| ST,AL |

| |
|---------|
| DIF MAT |
| PMMA |

Negro Preto 60 ●
Latonado Latão 27 ●Florón negro
Florão preta

Candle 1 Body Recessed

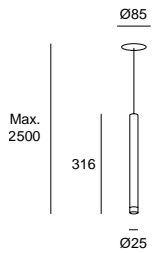

LED | K 2700 | CRI 90 | W Total 4.1 | Real Lm 154



ON-OFF 100-240V

Body

Code

27 ●
60 ●00-6018-27-27
00-6018-60-60

| |
|----------|
| BODY MAT |
| ST,AL |

| |
|---------|
| DIF MAT |
| PMMA |

Negro Preto 60 ●
Latonado Latão 27 ●

 65 3-30 mm
Florón blanco
Florão branco

Candle XXS 1 Body Surface

QS

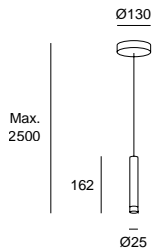

LED | K 2700 | CRI 90 | W Total 4.1 | Real Lm 154



ON-OFF 100-240V

Body

Code

27 ●
60 ●00-8527-27-27
00-8527-60-60

| |
|----------|
| BODY MAT |
| ST,AL |

| |
|---------|
| DIF MAT |
| PMMA |

Negro Preto 60 ●
Latonado Latão 27 ●Florón negro
Florão preta

Candle XXS 1 Body Recessed

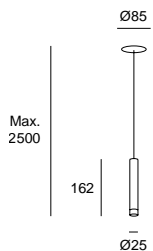

LED | K 2700 | CRI 90 | W Total 4.1 | Real Lm 154



ON-OFF 100-240V

Body

Code

27 ●
60 ●00-8528-27-27
00-8528-60-60

| |
|----------|
| BODY MAT |
| ST,AL |

| |
|---------|
| DIF MAT |
| PMMA |

Negro Preto 60 ●
Latonado Latão 27 ●

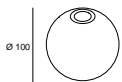
 65 3-30 mm
Florón blanco
Florão branco
No incluido
Não incluidoDisco de aluminio (1 unidad)
Disco de aluminio (1 unidade)

71-6022-60-60

Disco de aluminio (1 unidad)
Disco de aluminio (1 unidade)

71-6022-27-27

Accesorio Candle difusor vidrio matizado (1 unidad)
Acessório Candle difusor vidro matizado (1 unidade)

71-8318-F9-F9

Candle 3 Bodies

QS

| | |
|----------|---------|
| BODY MAT | DIF MAT |
| ST,AL | PMMA |

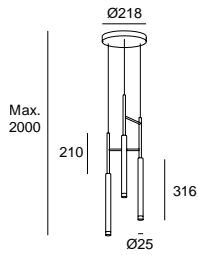

LED | K 2700 | CRI 90 | W Total 11.5 | Real Lm 461

Negro Preto 60 ●
Latonado Latão 27 ●

| | Body | Code |
|--------------------|------|---------------|
| PHASE CUT 220-240V | 27 ● | 00-6021-27-27 |
| | 60 ● | 00-6021-60-60 |

Florón negro
Florão preta

Candle 5 Bodies Chandelier

| | |
|----------|---------|
| BODY MAT | DIF MAT |
| ST,AL | PMMA |

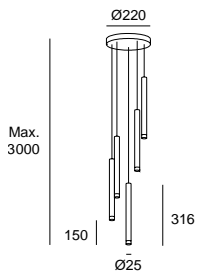

LED | K 2700 | CRI 90 | W Total 16.8 | Real Lm 844

Negro Preto 60 ●
Latonado Latão 27 ●

| | Canopy | Body | Code |
|-----------------|--------|------|---------------|
| DALI-2 100-240V | 60 ● | 27 ● | 00-8317-60-27 |
| | 60 ● | 60 ● | 00-8317-60-60 |

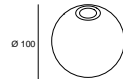

No incluido / Não incluído

Accesorio Candle difusor vidrio matizado (1 unidad)
Acessório Candle difusor vidro matizado (1 unidade)

71-8318-F9-F9

Candle XXS 5 Bodies Chandelier

| | |
|----------|---------|
| BODY MAT | DIF MAT |
| ST,AL | PMMA |

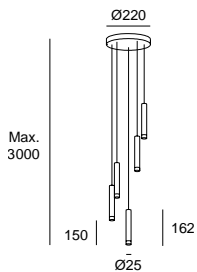

LED | K 2700 | CRI 90 | W Total 16.8 | Real Lm 844

Negro Preto 60 ●
Latonado Latão 27 ●

| | Canopy | Body | Code |
|-----------------|--------|------|---------------|
| DALI-2 100-240V | 60 ● | 27 ● | 00-8537-60-27 |
| | 60 ● | 60 ● | 00-8537-60-60 |

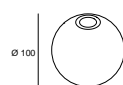

No incluido / Não incluído

Accesorio Candle difusor vidrio matizado (1 unidad)
Acessório Candle difusor vidro matizado (1 unidade)

71-8318-F9-F9

Candle 18 Bodies

| |
|----------|
| BODY MAT |
| ST,AL |

| |
|---------|
| DIF MAT |
| PMMA |

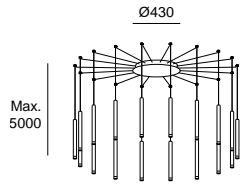

LED | K 2700 | CRI 90 | W Total 60.2 | Real Lm 2765

Blanco Branco 14
 Negro Preto 60
 Latonado Latão 27

| | Canopy | Body | Code |
|----------------|--------------------------|--------------------------|----------------------|
| 0-10V 100-277V | 14 <input type="radio"/> | 27 <input type="radio"/> | 00-6666-14-27 |
| | 14 <input type="radio"/> | 60 <input type="radio"/> | 00-6666-14-60 |
| DALI 100-277V | 14 <input type="radio"/> | 27 <input type="radio"/> | 00-6667-14-27 |
| | 14 <input type="radio"/> | 60 <input type="radio"/> | 00-6667-14-60 |

Candle XXS 18 Bodies

| |
|----------|
| BODY MAT |
| ST,AL |

| |
|---------|
| DIF MAT |
| PMMA |

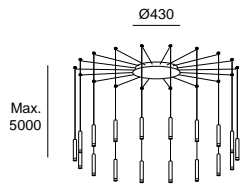

LED | K 2700 | CRI 90 | W Total 60.2 | Real Lm 2765

Blanco Branco 14
 Negro Preto 60
 Latonado Latão 27

| | Canopy | Body | Code |
|----------------|--------------------------|--------------------------|----------------------|
| 0-10V 100-277V | 14 <input type="radio"/> | 27 <input type="radio"/> | 00-8533-14-27 |
| | 14 <input type="radio"/> | 60 <input type="radio"/> | 00-8533-14-60 |
| DALI 100-277V | 14 <input type="radio"/> | 27 <input type="radio"/> | 00-8534-14-27 |
| | 14 <input type="radio"/> | 60 <input type="radio"/> | 00-8534-14-60 |

Candle 30 Bodies

BODY MAT
ST,AL

DIF MAT
PMMA

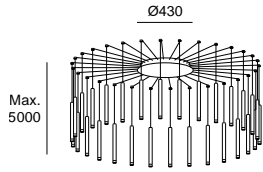

LED | K 2700 | CRI 90 | W Total 109.4 | Real Lm 4608

Blanco Branco 14
 Negro Preto 60
 Latonado Latão 27

| | Canopy | Body | Code |
|----------------|--------------------------|--------------------------|----------------------|
| O-10V 100-277V | 14 <input type="radio"/> | 27 <input type="radio"/> | 00-6668-14-27 |
| | 14 <input type="radio"/> | 60 <input type="radio"/> | 00-6668-14-60 |
| DALI 100-277V | 14 <input type="radio"/> | 27 <input type="radio"/> | 00-6669-14-27 |
| | 14 <input type="radio"/> | 60 <input type="radio"/> | 00-6669-14-60 |

Candle XXS 30 Bodies

BODY MAT
ST,AL

DIF MAT
PMMA

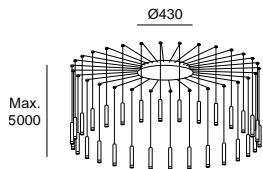

LED | K 2700 | CRI 90 | W Total 109.4 | Real Lm 4608

Blanco Branco 14
 Negro Preto 60
 Latonado Latão 27

| | Canopy | Body | Code |
|----------------|--------------------------|--------------------------|----------------------|
| O-10V 100-277V | 14 <input type="radio"/> | 27 <input type="radio"/> | 00-8535-14-27 |
| | 14 <input type="radio"/> | 60 <input type="radio"/> | 00-8535-14-60 |
| DALI 100-277V | 14 <input type="radio"/> | 27 <input type="radio"/> | 00-8536-14-27 |
| | 14 <input type="radio"/> | 60 <input type="radio"/> | 00-8536-14-60 |

Invisible



Performance Universe



P. 184

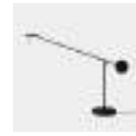

P. 226



P. 262

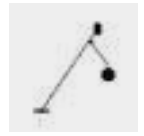

P. 292



Movimiento en equilibrio

Francesc Vilaró se inspiró en los móviles del escultor Alexander Calder para diseñar la colección Invisible, buscando el equilibrio entre las líneas que forman la estructura y el círculo que las une haciendo de contrapeso. En esta composición de balances, la luz puede dirigirse a cualquier punto, proyectando una luz de acento de forma muy honesta, con una gran libertad de movimientos en todas sus versiones. Invisible es una pieza icónica que ha recibido el premio German Design Award.



Movimento em equilíbrio

Francesc Vilaró inspirou-se nos móveis do escultor Alexander Calder para criar a coleção Invisible, procurando um equilíbrio entre as linhas que formam a estrutura e o círculo que as une como contrapeso. Nesta composição de equilíbrios, a luz pode ser dirigida para qualquer ponto, projetando uma luz de realce de uma forma muito honesta, com uma grande liberdade de movimentos em todas as suas versões. Invisible é uma peça icónica que recebeu o German Design Award.



Invisible Single Fixed

QS

| | | | |
|----------|---------|--|--|
| BODY MAT | DIF MAT |  |  |
| ST.AL | PMMA | | |

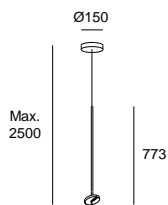

LED | CRI 90 | W Total 12.2

Negro Preto 05 ●

|  | K | Real Lm | Structure | Code |
|---|------|---------|-----------|----------------------|
| PHASE CUT 220-240V | 2700 | 551 | 05 ● | 00-7382-05-05 |
| | 3000 | 568 | 05 ● | 00-5693-05-05 |

Invisible Single Adjustable

QS

| | | | | |
|----------|---------|---|---|---|
| BODY MAT | DIF MAT |  |  |  |
| ST.AL | PMMA | | | |

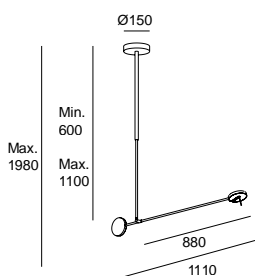



LED | CRI 90 | W Total 10.5

Negro Preto 05 ●

|  | K | Real Lm | Structure | Code |
|---|------|---------|-----------|----------------------|
| PHASE CUT 220-240V | 2700 | 534 | 05 ● | 00-7383-05-05 |
| | 3000 | 550 | 05 ● | 00-5694-05-05 |

Invisible 3 Bodies

| | | | |
|----------|---------|---|---|
| BODY MAT | DIF MAT |  |  |
| ST.AL | PMMA | | |

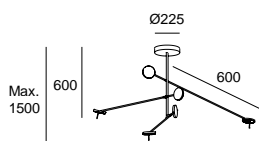

LED | CRI 90 | W Total 28.5

Negro Preto 05 ●

|  | K | Real Lm | Structure | Code |
|---|------|---------|-----------|-------------------------|
| ON-OFF 100-240V | 2700 | 1602 | 05 ● | 00-7384-05-05 QS |
| ON-OFF 100-240V | 3000 | 1650 | 05 ● | 00-5695-05-05 |
| PHASE CUT 220-240V | 2700 | 1602 | 05 ● | 00-7385-05-05 QS |
| PHASE CUT 220-240V | 3000 | 1650 | 05 ● | 00-5696-05-05 QS |



La rotación del cabezal permite dirigir la luz.
A rotação do cabeçal permite dirigir a luz.

Prolix



Performance Universe



P. 294



P. 350



Estilo y elegancia

Contemporaneidad, estilo y control del ángulo luz son los pilares sobre los que se sustenta esta propuesta de Nahtrang. Prolix, no sólo presume de su silueta facetada, sino que cuenta con una gran ventaja técnica gracias a una óptica avanzada que posibilita graduar el ángulo de luz para conseguir el efecto de iluminación deseado.

Estilo e elegância

Contemporaneidade, estilo e controlo do ângulo de luz são os pilares sobre os quais esta proposta de Nathrang se baseia. Prolix não só ostenta a sua silhueta facetada, como também uma grande vantagem técnica graças a uma óptica avançada que permite ajustar o ângulo de luz para obter o efeito de iluminação desejado.



Óptica regulable para aumentar el ángulo de luz. (Zoom 15°-50°)
Ótica regulável para aumentar o ângulo da luz. (Zoom 15°-50°)



Llave para ajustar la óptica de forma manual.
Chave para ajustar a ótica manualmente.

Prolix Surface

QS

| | |
|----------|---------|
| BODY MAT | DIF MAT |
| AL | PMMA |

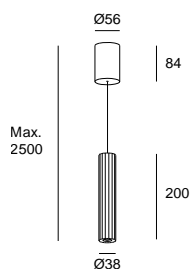

LED | K 2700 | CRI 90 | W Total 10.4 | Real Lm 320

Negro Preto 05 ●
Oro mate Ouro mate DN ●

| | Canopy | Body | Code |
|--------------------|--------------|--------------|--------------------------------|
| PHASE CUT 220-240V | 05 ● DN ● | 05 ● DN ● | 00-8513-05-05 00-8513-DN-DN |

QS Quick Service | 2-6 días laborables (tiempo de transporte no incluido)
Quick Service | 2-6 dias úteis (tempo de transporte não incluído)

Prolix Recessed

| | |
|----------|---------|
| BODY MAT | DIF MAT |
| AL | PMMA |

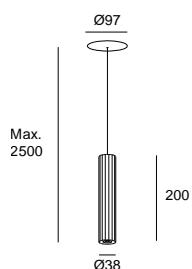

LED | K 2700 | CRI 90 | W Total 10.4 | Real Lm 320

Negro Preto 05 ●
Oro mate Ouro mate DN ●

| | Body | Code |
|--------------------|--------------|--------------------------------|
| PHASE CUT 220-240V | 05 ● DN ● | 00-8514-05-05 00-8514-DN-DN |

65 3-30 mm

Florón blanco
Florão branco

Dew



Performance Universe



La belleza de lo efímero

Dew es una composición orgánica que explora la luz y la belleza efímera, inspirándose en las gotas del rocío una mañana de primavera. Con una configuración lineal formada por una línea de puntos ovalados conectados por piezas de aluminio a distancias variables, esta colección es una colección decorativa con un fuerte carácter técnico. Dew se presenta con variaciones tanto verticales como horizontales, lo que hace posible cualquier combinación y ángulo.

A beleza do efêmero

Dew é uma composição orgânica que explora a luz e a beleza efêmera, inspirada nas gotas de orvalho numa manhã de primavera. Com uma configuração linear formada por uma linha de pontos ovais ligados por peças de alumínio a distâncias variáveis, esta coleção é uma coleção decorativa com um forte caráter técnico. Dew apresenta-se com variações tanto verticais como horizontais, tornando possível qualquer combinação e ângulo.

Compatible con instalaciones que precisen de grandes alturas.
Compatível com instalações que exijam grandes alturas.









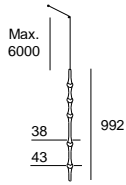

Dew 992mm

| | |
|----------|---------|
| BODY MAT | DIF MAT |
| AL | PC |

LED | K 2700 | CRI 90 | W Total 13 | Real Lm 782

Negro Preto 05 ●
Blanco opal Branco opalino M1 ○



| | Structure | Difusor | Code |
|--|-----------|---------|-------------------------|
|  Ø160  DALI 220-240V | 05 ● | M1 ○ | 00-8304-05-M1 QS |
|  Ø97  0-10V 220-240V | 05 ● | M1 ○ | 00-8305-05-M1 |
|  Ø50  PUSH 220-240V | 05 ● | M1 ○ | 00-8656-05-M1 |
|  Ø50  PUSH 220-240V | 05 ● | M1 ○ | 00-8658-05-M1 |







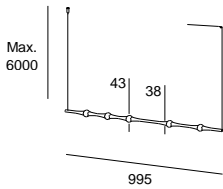

Dew 995mm

| | |
|----------|---------|
| BODY MAT | DIF MAT |
| AL | PC |

LED | K 2700 | CRI 90 | W Total 13 | Real Lm 782

Negro Preto 05 ●
Blanco opal Branco opalino M1 ○



| | Structure | Difusor | Code |
|---|-----------|---------|-------------------------|
|  Ø160  DALI 220-240V | 05 ● | M1 ○ | 00-8302-05-M1 QS |
|  Ø97  0-10V 220-240V | 05 ● | M1 ○ | 00-8303-05-M1 |
|  Ø50  PUSH 220-240V | 05 ● | M1 ○ | 00-8646-05-M1 |
|  Ø50  PUSH 220-240V | 05 ● | M1 ○ | 00-8648-05-M1 |







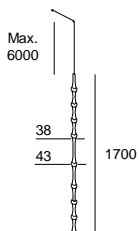

Dew 1700mm

| | |
|----------|---------|
| BODY MAT | DIF MAT |
| AL | PC |

LED | K 2700 | CRI 90 | W Total 21.1 | Real Lm 1383

Negro Preto 05 ●
Blanco opal Branco opalino M1 ○



| | Structure | Difusor | Code |
|--|-----------|---------|-------------------------|
|  Ø160  DALI 220-240V | 05 ● | M1 ○ | 00-8306-05-M1 QS |
|  Ø97  0-10V 220-240V | 05 ● | M1 ○ | 00-8307-05-M1 |
|  Ø50  PUSH 220-240V | 05 ● | M1 ○ | 00-8667-05-M1 |
|  Ø50  PUSH 220-240V | 05 ● | M1 ○ | 00-8669-05-M1 |

Florón en superficie
Florão de superfície

Florón empotrado
Florão encastrado

Florón empotrado mini
Florão encastrado mini



Alive



Performance Universe



Transición del vacío hacia el punto de luz

Alive representa la mínima expresión para llegar al punto de luz de forma silenciosa. Con una progresión armónica, su diseño responde a una transición del vacío hacia la luz. Esta reducción cambia cuando la composición se realiza con el difusor de cristal matizado que se opaliza progresivamente, pasando de una luz de acento a una luz ambiental muy agradable.

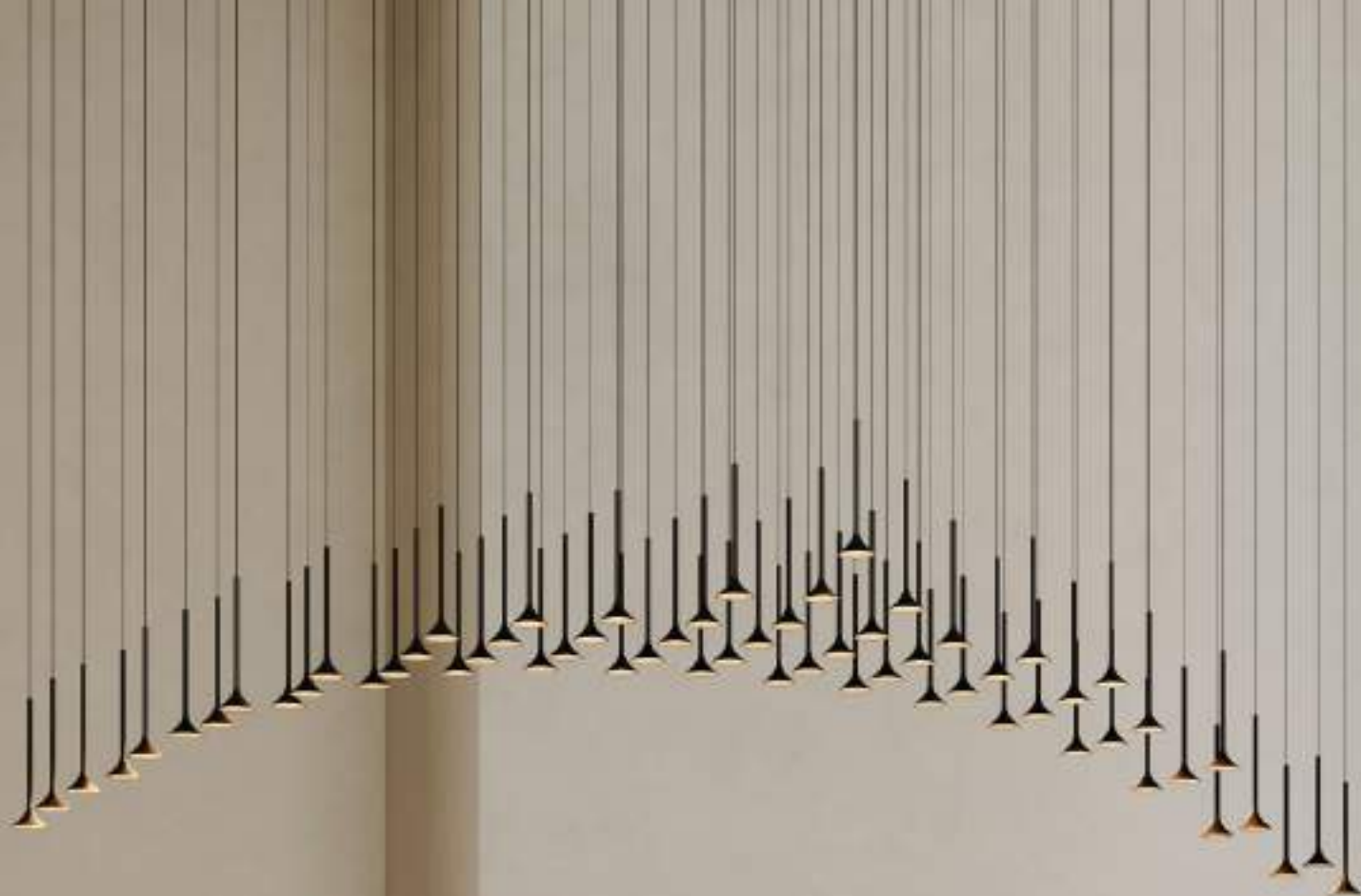

Transição do vazio para o ponto de luz

Alive representa a expressão mínima para atingir o ponto de luz de forma silenciosa. Com uma progressão harmónica, o seu design responde a uma transição do vazio para a luz. Esta redução muda quando a composição é feita com o difusor em vidro matizado que se torna progressivamente opaco, passando de uma luz de realce para uma luz ambiente muito agradável.



Alive Single

QS

| | | | |
|----------|---------|--|--|
| BODY MAT | DIF MAT |  |  |
| ST,AL | PMMA | | |

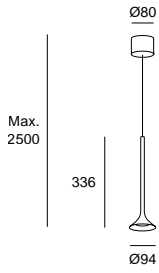

LED | K 2700 | CRI 80 | W Total 8.5 | Real Lm 492

Negro Preto 05 ●



ON-OFF 100-240V

Structure



Code

05 ●

00-6670-05-05

Alive Single with glass difusor

QS

| | | | |
|----------|-----------|---|---|
| BODY MAT | DIF MAT |  |  |
| ST,AL | PMMA, GLA | | |

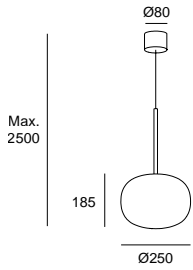

LED | K 2700 | CRI 80 | W Total 8.5 | Real Lm 454

Negro Preto 05 ●
Cristal arenado Vidro fosco F1 ○

ON-OFF 100-277V

Structure

Difusor

Code

05 ●

F1 ○

00-6671-05-F1



Opción con difusor oval de cristal matizado soplado artesanalmente.
Opção com difusor oval de vidro matizado soprado artesanalmente.

Punto



Essential Universe



Gran personalidad en un mínimo punto de luz

Punto es una colección de colgantes que concentra una gran personalidad en un mínimo punto de luz. La versión simple se integra en el espacio de forma discreta y suave; la opción múltiple, en cambio, puede componerse de una forma mucho más compleja, siempre conservando su alto valor estético.

Grande personalidade num mínimo ponto de luz

Punto é uma coleção de suspensos que concentra uma grande personalidade num mínimo ponto de luz. A versão simples integra-se no espaço de forma discreta e suave; a opção múltipla, por outro lado, pode ser composta de uma forma muito mais complexa, conservando sempre o seu alto valor estético.



Punto Single Surface

QS

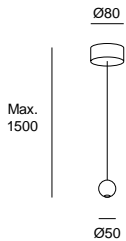

LED | K 3000 | CRI 90 | W Total 6.5 | Real Lm 329

Negro Preto 05 ●



Structure

Code

ON-OFF 220-240V

05 ●

00-A232-05-05

Punto Single Recessed

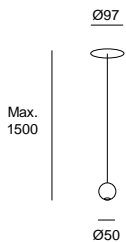
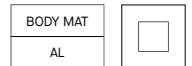

LED | K 3000 | CRI 90 | Real Lm 329

Negro Preto 05 ●



W Total

Structure

Code

PHASE CUT / PUSH 220-240V

6.5

05 ●

00-7900-05-05

DALI-2 / PUSH 100-240V

8.2

05 ●

00-7901-05-05

ON-OFF 100-277V

6.5

05 ●

00-7899-05-05

65 3-30 mm

Floron blanco
Florao branco

Punto Multiple Surface

QS

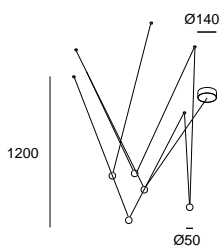

LED | K 3000 | CRI 90 | W Total 24.3 | Real Lm 625

Negro Preto 05 ●



Structure

Code

ON-OFF 220-240V

05 ●

00-A337-05-05

Mist



Essential Universe



P. 368



Un clásico contemporáneo

Con sencillez y acierto Mist representa la renovación de un clásico.

Um clássico contemporâneo

Com simplicidade e acerto Mist representa a renovação de um clássico.

Mist Pendant

| | | | |
|----------|---------|--|----|
| BODY MAT | DIF MAT | | IP |
| ST | GLA | | 44 |

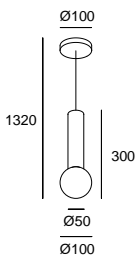

E14 Max. L 97 mm - Ø 35 mm | W Max. 9

| Structure | Difussor |
|-----------|----------|
| 05 ● | F9 ○ |
| 21 ● | F9 ○ |

Code

00-8337-05-F9
00-8337-21-F9

- Negro Preto 05 ●
- Cromo Cromado 21 ●
- Arenado Areado F9 ○

Circ



Performance Universe



La elegancia de las formas neutras

Inspirándose en las tradicionales carpas de circo, el diseñador Josep Patsí crea una luminaria circular con distintas medidas y composiciones que se adapta a los espacios con la elegancia de una forma neutra, sin elementos añadidos.

A elegância das formas neutras

Inspirada nas tradicionais tendas de circo, o designer Josep Patsí criou uma luminária circular com diferentes tamanhos e composições que se adapta a espaços com a elegância de uma forma neutra, sem elementos adicionados.



Modelos individuales o múltiples.
Modelos individuais ou múltiplos.

Circ Ø600

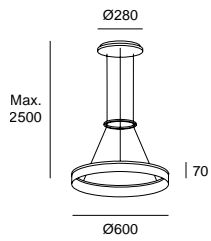
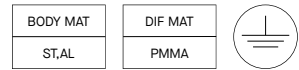

LED | K 3000 | CRI 80 | W Total 31 | Real Lm 1577

Blanco Branco BW
Anodizado Anodizado M3

| | Canopy | Structure | Code |
|-----------------|--------------------------|-------------------------------------|----------------------|
| ON-OFF 100-240V | BW <input type="radio"/> | M3 <input checked="" type="radio"/> | 00-0001-BW-M3 |
| 1-10V 100-240V | BW <input type="radio"/> | M3 <input checked="" type="radio"/> | 00-0641-BW-M3 |

Circ Ø800

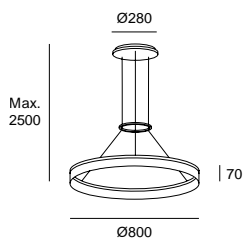
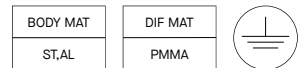

LED | K 3000 | CRI 80 | W Total 45.1 | Real Lm 2086

Blanco Branco BW
Anodizado Anodizado M3

| | Canopy | Structure | Code |
|-----------------|--------------------------|-------------------------------------|----------------------|
| ON-OFF 100-240V | BW <input type="radio"/> | M3 <input checked="" type="radio"/> | 00-0002-BW-M3 |
| 1-10V 100-240V | BW <input type="radio"/> | M3 <input checked="" type="radio"/> | 00-0642-BW-M3 |

Circ Ø1000

| | |
|----------|---------|
| BODY MAT | DIF MAT |
| ST,AL | PMMA |

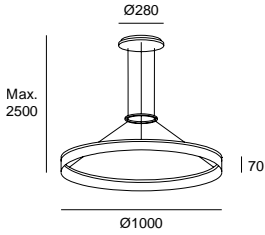

LED | K 3000 | CRI 80 | W Total 49.3 | Real Lm 3473

 Blanco Branco BW
 Anodizado Anodizado M3

| | Canopy | Structure | Code |
|-----------------|--------------------------|-------------------------------------|----------------------|
| ON-OFF 100-240V | BW <input type="radio"/> | M3 <input checked="" type="radio"/> | 00-3642-BW-M3 |
| 1-10V 100-240V | BW <input type="radio"/> | M3 <input checked="" type="radio"/> | 00-3646-BW-M3 |

Circ Ø600 + Ø800

| | |
|----------|---------|
| BODY MAT | DIF MAT |
| ST,AL | PMMA |

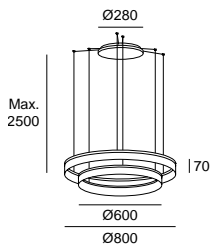

LED | K 3000 | CRI 80 | W Total 58 | Real Lm 3799

 Blanco Branco BW
 Anodizado Anodizado M3

| | Canopy | Structure | Code |
|-----------------|--------------------------|-------------------------------------|----------------------|
| ON-OFF 100-240V | BW <input type="radio"/> | M3 <input checked="" type="radio"/> | 00-3647-BW-M3 |

Circ Ø800 + Ø1000

| | |
|----------|---------|
| BODY MAT | DIF MAT |
| ST,AL | PMMA |

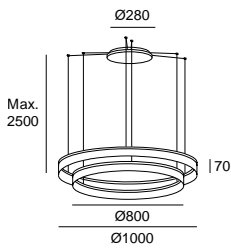

LED | K 3000 | CRI 80 | W Total 72 | Real Lm 6171

 Blanco Branco BW
 Anodizado Anodizado M3

| | Canopy | Structure | Code |
|-----------------|--------------------------|-------------------------------------|----------------------|
| ON-OFF 100-240V | BW <input type="radio"/> | M3 <input checked="" type="radio"/> | 00-3648-BW-M3 |

Circ Ø600 + Ø800 + Ø1000

| | |
|----------|---------|
| BODY MAT | DIF MAT |
| ST,AL | PMMA |

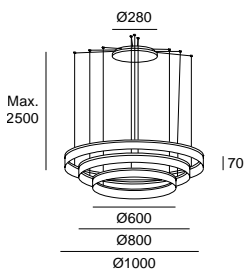

LED | K 3000 | CRI 80 | W Total 94 | Real Lm 7136

 Blanco Branco BW
 Anodizado Anodizado M3

| | Canopy | Structure | Code |
|-----------------|--------------------------|-------------------------------------|----------------------|
| ON-OFF 100-240V | BW <input type="radio"/> | M3 <input checked="" type="radio"/> | 00-3649-BW-M3 |

Caprice



Performance Universe



P. 344



Exigencia lumínica

Caprice ofrece diversidad de funciones avanzadas en un producto decorativo que se adapta a ambientes con grandes exigencias lumínicas.

Exigência lumínica

Caprice oferece diversidade de funções avançadas num produto decorativo que se adapta a ambientes com grandes exigências lumínicas.

Cuenta con un switch integrado.
Possui um switch integrado.

Caprice Ø240mm

| | | | |
|----------|---------|--|----------------|
| BODY MAT | DIF MAT |  | SWITCH CCT |
| ST | ACR | | 2700-3000-4000 |

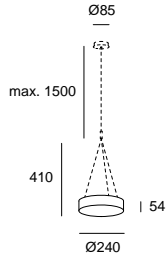

LED | K SW 2700-3000-4000 | CRI 90 | W Total 14.1 | Real Lm 896

Blanco Branco 14
 Negro Preto 60
 Blanco opal Branco opalino M1

| | Body | Difussor | Code |
|--------------------|---|--|--|
| PHASE CUT 220-240V | 14 <input type="radio"/> 60 <input checked="" type="radio"/> | M1 <input type="radio"/> M1 <input type="radio"/> | 15-6196-14-M1 15-6196-60-M1 |

Acabados The Colours bajo pedido mínimo de 15 unidades. Consultar precios en tarifa y plazos de entrega con equipo comercial.
 Acabamentos The Colours sujeitos a encomenda mínima de 15 unidades. Consultar preços e prazos de entrega com a nossa equipa comercial.

Body: DL Oro Ouro Difussor: M1 Blanco opal Branco opalino

Caprice Ø330mm

| | | | |
|----------|---------|---|----------------|
| BODY MAT | DIF MAT |  | SWITCH CCT |
| ST | ACR | | 2700-3000-4000 |

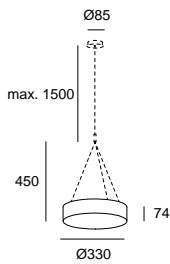

LED | K SW 2700-3000-4000 | CRI 90 | W Total 20 | Real Lm 1258

Blanco Branco 14
 Negro Preto 60
 Blanco opal Branco opalino M1

| | Body | Difussor | Code |
|--------------------|---|--|--|
| PHASE CUT 220-240V | 14 <input type="radio"/> 60 <input checked="" type="radio"/> | M1 <input type="radio"/> M1 <input type="radio"/> | 15-6197-14-M1 15-6197-60-M1 |

Acabados The Colours bajo pedido mínimo de 15 unidades. Consultar precios en tarifa y plazos de entrega con equipo comercial.
 Acabamentos The Colours sujeitos a encomenda mínima de 15 unidades. Consultar preços e prazos de entrega com a nossa equipa comercial.

Body: DL Oro Ouro Difussor: M1 Blanco opal Branco opalino

Caprice Ø520mm

| | | | |
|----------|---------|---|----------------|
| BODY MAT | DIF MAT |  | SWITCH CCT |
| ST | ACR | | 2700-3000-4000 |

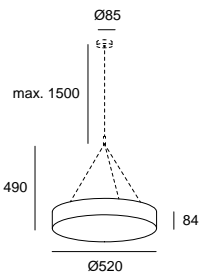

LED | K SW 2700-3000-4000 | CRI 90 | W Total 39.6 | Real Lm 3072

Blanco Branco 14
 Negro Preto 60
 Blanco opal Branco opalino M1

| | Body | Difussor | Code |
|--------------------|---|--|--|
| PHASE CUT 220-240V | 14 <input type="radio"/> 60 <input checked="" type="radio"/> | M1 <input type="radio"/> M1 <input type="radio"/> | 15-6433-14-M1 15-6433-60-M1 |

Acabados The Colours bajo pedido mínimo de 15 unidades. Consultar precios en tarifa y plazos de entrega con equipo comercial.
 Acabamentos The Colours sujeitos a encomenda mínima de 15 unidades. Consultar preços e prazos de entrega com a nossa equipa comercial.

Body: DL Oro Ouro Difussor: M1 Blanco opal Branco opalino

No incluidos y requeridos
 Não incluído e requeridos

Kit suspensión blanco
 Kit suspensão branco

71-6196-14-14

*Consulte condiciones y plazos de entrega a nuestro equipo comercial.

*Consultar a nossa equipa comercial para informações sobre as condições e os prazos de entrega.

Pipe



Essential Universe



P. 196



P. 354



Funcionalidad

Pipe es sinónimo de practicidad e integración. Un diseño funcional que permite cierta personalización para que su instalación siempre sea un acierto.

Funcionalidade

Pipe é sinónimo de praticidade e integração. Um design funcional que permite uma certa personalização para que a sua instalação seja sempre um acerto.



05-23



14-05



14-14



05-05

Combinaciones standard.
Combinações padrão.

Posibilidad de otras combinaciones mediante aros no incluidos.
Possibilidade de outras combinações por aros não incluídos.

Pipe 300mm

QS

BODY MAT
ST,AL

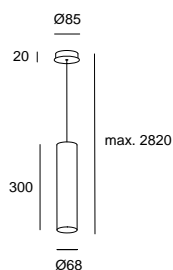

GU10 | W Max. 8

Blanco Branco 14 ○
Negro Preto 05 ●
Oro Ouro 23 ●

| Structure | Ring | Code |
|-----------|------|---------------|
| 05 ● | 23 ● | 00-5456-05-23 |
| 14 ○ | 05 ● | 00-5456-14-05 |

*Bombilla no incluída.
*Lâmpada não incluída.

No incluido / Não incluído

Accesorio para empotrar el florón blanco 71-5456-14-14
Acessório para encastrar o florão branco

Acc. comunes no incluídos
Ac. comuns não incluídos

Aro blanco 71-0073-14-14
Aro branco
Aro negro 71-0073-05-05
Aro preto

Stylus



Essential Universe



P. 198



P. 355



Sencillez y funcionalidad

Stylus es un diseño altamente funcional y versátil gracias a sus medidas y acabados.

Simplicidade e funcionalidade

Stylus é um design altamente funcional e versátil graças às suas medidas e acabamentos.

Stylus Surfaced 600mm

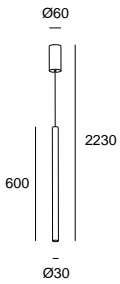

| | | |
|----------|---------|--|
| BODY MAT | DIF MAT | |
| AL | PC | |

- Blanco Branco 14
- Negro Preto 05
- Oro mate Ouro mate DN

LED | K 3000 | CRI 90 | W Total 9.7 | Real Lm 412

| | Canopy | Body | Code |
|-----------------|--------------------------|--------------------------|--------------------------------|
| | | | |
| ON-OFF 220-240V | 05 <input type="radio"/> | 05 <input type="radio"/> | 00-A017-05-05 QS |
| | 14 <input type="radio"/> | 14 <input type="radio"/> | 00-A017-14-14 |
| | DN <input type="radio"/> | DN <input type="radio"/> | 00-A017-DN-DN QS |

Stylus Recessed 600mm

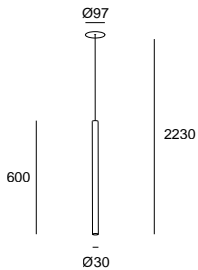

| | | |
|----------|---------|--|
| BODY MAT | DIF MAT | |
| AL | PC | |

- Blanco Branco 14
- Negro Preto 05
- Oro mate Ouro mate DN

LED | K 3000 | CRI 90 | W Total 9.7 | Real Lm 412

| | Body | Code |
|-----------------|--------------------------|----------------------|
| | | |
| ON-OFF 220-240V | 05 <input type="radio"/> | 00-A018-05-05 |
| | 14 <input type="radio"/> | 00-A018-14-14 |
| | DN <input type="radio"/> | 00-A018-DN-DN |

3-30 mm 65

Bravo



Performance Universe

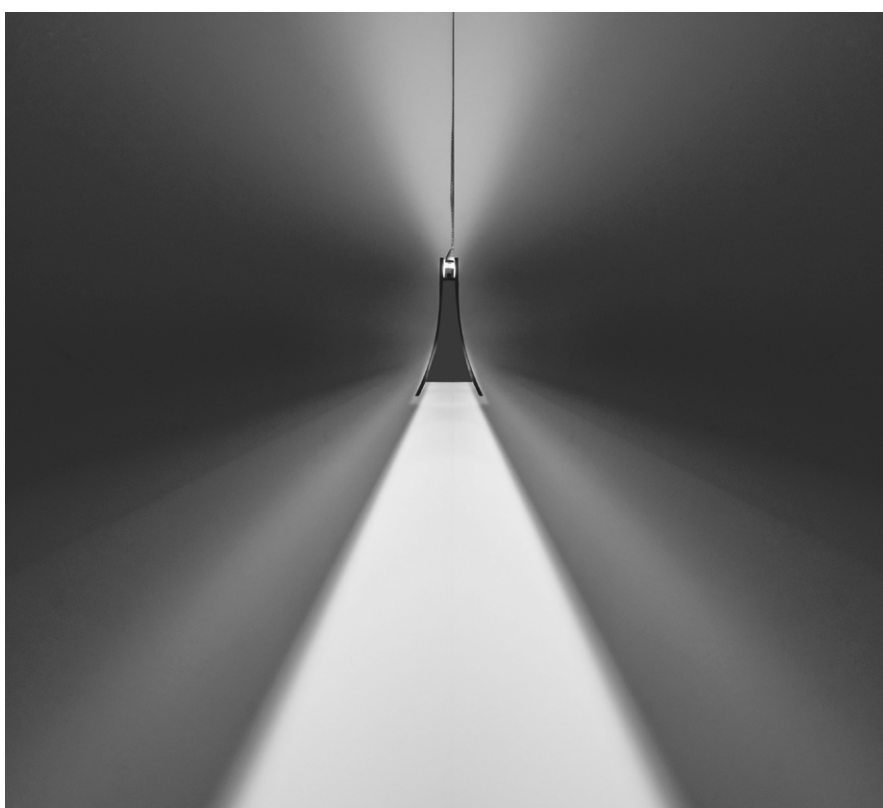





Iluminación Up&Down
Iluminação Up&Down

Bravo

| | |
|----------|---------|
| BODY MAT | DIF MAT |
| AL | ACR |

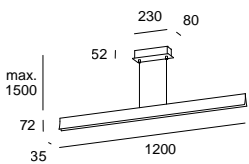

LED | K 3000 | CRI 80 | Real Lm 3075

Oro Ouro F5
Blanco opal Branco opalino M1

| | W Total | Structure | Difussor | Code |
|--------------------|---------|-------------------------------------|--------------------------|--------------------------------|
| ON-OFF 110-240V | 40.7 | F5 <input checked="" type="radio"/> | M1 <input type="radio"/> | 00-4925-F5-M1 QS |
| PHASE CUT 220-240V | 42.2 | F5 <input checked="" type="radio"/> | M1 <input type="radio"/> | 00-4926-F5-M1 |

Bol



Performance Universe



P. 348



Bol Ø450mm

| | | |
|----------|---------|--|
| BODY MAT | DIF MAT | |
| ST | ACR,TEX | |

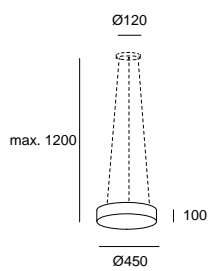

LED | K 3000 | CRI 80 | W Total 23 | Real Lm 1064

Arena Areia BY
Blanco opal Branco opalino M1

| | Body | Difussor | Code |
|-----------------|-------------------------------------|--------------------------|----------------------|
| ON-OFF 100-240V | BY <input checked="" type="radio"/> | M1 <input type="radio"/> | 15-4922-BY-M1 |

Bol Ø750mm

| | | |
|----------|---------|--|
| BODY MAT | DIF MAT | |
| ST | ACR,TEX | |

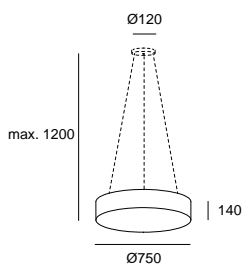

LED | K 3000 | CRI 80 | W Total 33 | Real Lm 1646

Arena Areia BY
Blanco opal Branco opalino M1

| | Body | Difussor | Code |
|-----------------|-------------------------------------|--------------------------|----------------------|
| ON-OFF 100-240V | BY <input checked="" type="radio"/> | M1 <input type="radio"/> | 15-A052-BY-M1 |

No incluidos y requeridos
Não incluído e requeridos

Kit suspensión
Kit suspensão

71-4695-81-81

Lectura Leitura



Invisible

184



Perlina

182



Chic

186



E-lamp

188



E-lamp Mini 190



Hall Slim 191

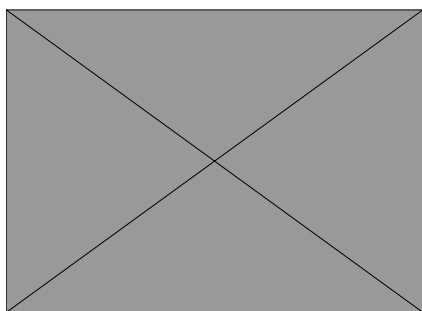

Gamma 192



Gamma Mini 193



Gamma Extend 194



Radar

195



Simply

197



Pipe

196



Stylus

198



Bed

199



Link

200



Tip

201



Clip

202



Metrica

204

Perlina



Performance Universe



P. 220



P. 254



P. 276



P. 358



Joia natural

Perlina se inspira en una joya natural para ofrecer una perla iluminada que juega con la esencia de la circunferencia, redonda y perfecta, dando sentido al minimalismo de lo básico. Cuando está encendida, su efecto de luz tamizada transmite un sentimiento de calma llenando el espacio con naturalidad y acomodándose a él gracias a la posibilidad de regulación manual mediante dimmer.

Joia natural

Perlina inspira-se numa joia natural para oferecer uma pérola iluminada que brinca com a essência da circunferência, redonda e perfeita, dando sentido ao minimalismo do básico. Quando acesa, o seu efeito de luz filtrada transmite uma sensação de calma, preenchendo naturalmente o espaço e adaptando-se a ele graças à possibilidade de regulação manual através de dimmer.



Perlina USB

QS

| | | | | |
|----------|---------|--|----------------|--|
| BODY MAT | DIF MAT | | SWITCH CCT | |
| AISI304 | GLA | | 2700-3000-4000 | |

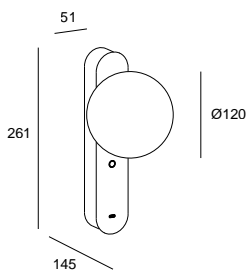

LED | K 2700-3000-4000 | CRI 90 | W Total 8.8 | Real Lm 391 (3000K)

Negro Preto 60 ●
Oro mate Ouro mate DN ●



Structure Code

TOUCH DIMMING 220-240V

60 ● **05-A078-60-60**
DN ● **05-A078-DN-DN**

QS Quick Service | 2-6 días laborables (tiempo de transporte no incluido)
Quick Service | 2-6 dias úteis (tempo de transporte não incluído)

Invisible



Performance Universe



P. 151

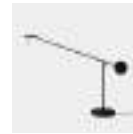

P. 226



P. 262

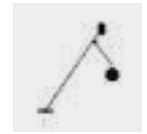

P. 292



Movimiento en equilibrio

Francesc Vilaró se ha inspirado en los móviles del escultor Alexander Calder para diseñar la colección, buscando el equilibrio entre las líneas que forman la estructura y su contrapeso. En esta composición de balances, la luz puede dirigirse a cualquier punto, proyectando una luz de acento de forma muy honesta, con una gran libertad de movimientos.

Movimento em equilíbrio

Francesc Vilaró inspirou-se nos móveis do escultor Alexander Calder para criar a coleção, procurando um equilíbrio entre as linhas que formam a estrutura e o seu contrapeso. Nesta composição de equilíbrios, a luz pode ser dirigida para qualquer ponto, projetando uma luz de realce de uma forma muito honesta, com uma grande liberdade de movimentos.





La rotación del cabezal permite dirigir la luz.

A rotação da cabeça permite dirigir a luz.

Invisible Reader Small

QS

| | | | | | | |
|----------|---------|--|------|----------|--|-----|
| BODY MAT | DIF MAT | | | | | |
| ST,AL | PMMA | | 180° | 0° - 90° | | DIM |

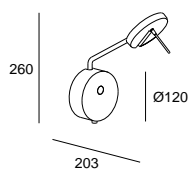

LED | CRI 90 | W Total 10,5

Negro Preto 05 ●

| | K | Real Lm | Structure | Code |
|---------------|------|---------|-----------|----------------------|
| TOUCH DIMMING | 2700 | 534 | 05 ● | 05-7382-05-05 |
| 100-240V | 3000 | 550 | 05 ● | 05-7380-05-05 |

Invisible Reader Large

QS

| | | | | | | |
|----------|---------|--|------|----------|--|-----|
| BODY MAT | DIF MAT | | | | | |
| ST,AL | PMMA | | 180° | 0° - 90° | | DIM |

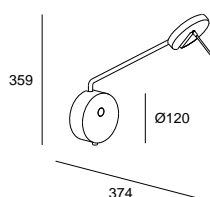

LED | CRI 90 | W Total 10,5

Negro Preto 05 ●

| | K | Real Lm | Structure | Code |
|---------------|------|---------|-----------|----------------------|
| TOUCH DIMMING | 2700 | 534 | 05 ● | 05-7383-05-05 |
| 100-240V | 3000 | 550 | 05 ● | 05-7381-05-05 |

Chic



Performance Universe



Calidad en la mínima expresión

Aplique de lectura de tamaño muy compacto con un elevado componente técnico. Gracias a su desarrollo y al confort visual obtenido, Chic cumple su funcionalidad sin renunciar al diseño y al factor decorativo.

Qualidade na mínima expressão

Aplique de leitura em tamanho muito compacto com uma elevada componente técnica. Graças ao seu desenvolvimento e ao conforto visual obtido, Chic cumpre a sua funcionalidade sem renunciar ao design e ao fator decorativo.



Incluye panel de abeja para mayor confort visual.

Inclui um painel de abelha para maior conforto visual.

Chic

| | | | | | | |
|----------|---------|--|------|-----|--|--|
| BODY MAT | DIF MAT | | | | | |
| AL | PMMA | | 360° | 90° | | |

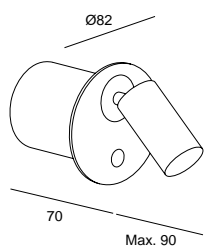

LED | K 2700 | CRI 90 | W Total 3.9 | Real Lm 200

- Blanco Branco 14
- Negro Preto 05
- Oro mate Ouro mate DN



TOUCH DIMMING 100-240V

| Structure | Code |
|-----------|---------------|
| 05 | 05-8509-05-05 |
| 14 | 05-8509-14-14 |
| DN | 05-8509-DN-DN |

60 10 mm

E-lamp



Performance Universe



P. 190



Multifuncional

E-lamp es una colección de diseño racional y simple, basado en formas geométricas básicas. Esta familia multifuncional de luminarias busca la armonía e integración en el espacio. Centrada en el teléfono móvil, incluye USB en todas sus versiones y tecnología Wireless Charging en la opción sobremesa.

Multifuncional

E-lamp é uma coleção de design racional e simples, baseada em formas geométricas básicas. Esta família no espaço. Centrada no telemóvel, inclui USB em todas as suas versões e tecnologia Wireless Charging na opção de mesa.



Opción de botones dorados en los dos acabados.
Opção de botões dourados em ambos os acabamentos.

Carga de aparatos electrónicos mediante USB.
Carrega dispositivos eletrónicos via USB.

E-lamp

| | | | | | |
|----------|--|------|-----|----|-------|
| BODY MAT | | | | | |
| AL | | 180° | 90° | x2 | USB C |

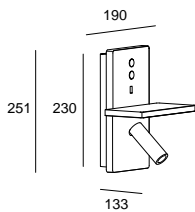

LED+LED | K 2700 | CRI 80 | W Total 12.3 | Real Lm 469

- Blanco Branco 14
- Negro Preto 05
- Latón pulido Latão polido DO



ON-OFF 220-240V

| Structure | Button | Code |
|-----------|--------|----------------------|
| 05 | 05 | 05-7606-05-05 |
| 05 | DO | 05-7606-05-DO |
| 14 | 14 | 05-7606-14-14 |
| 14 | DO | 05-7606-14-DO |

E-lamp Mini



Performance Universe



P. 188



Posibilidad de instalación vertical u horizontal.
Possibilidade de instalação vertical e horizontal.



Carga de aparatos electrónicos mediante USB.
Carrega dispositivos eletrónicos via USB.

E-lamp Mini

QS

| | | | | | |
|----------|-----|-----|--|-------|--|
| BODY MAT | | | | | |
| AL | 180 | 90° | | USB C | |

| | | | |
|----------------------------------|----|-----------------------------------|----|
| Blanco Branco | 14 | Oro mate Ouro mate | DN |
| Negro Preto | 05 | Blanco brillante Branco brilhante | EU |
| Níquel satinado Níquel acetinado | 81 | Negro brillante Preto brilhante | EV |

LED | K 2700 | CRI 90 | W Total 3.2 | Real Lm 137

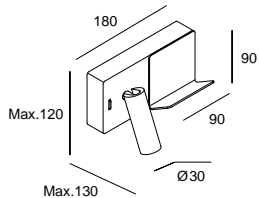

| Structure | Body | Code |
|-----------|------|----------------------|
| 05 ● | 81 ● | 05-8329-05-81 |
| 05 ● | DN ● | 05-8329-05-DN |
| 05 ● | EV ● | 05-8329-05-EV |
| 14 ○ | 81 ● | 05-8329-14-81 |
| 14 ○ | DN ● | 05-8329-14-DN |
| 14 ○ | EU ○ | 05-8329-14-EU |

ON-OFF 100-240V



QS Quick Service | 2-6 días laborables (tiempo de transporte no incluido)
Quick Service | 2-6 dias úteis (tempo de transporte não incluído)

Hall Slim



Performance Universe



Elegancia discreta

Hall Slim es una colección con un perfil compacto y rectilíneo que se presenta con distintos acabados que permiten integrar una luz de lectura orientable de manera discreta.

Elegância discreta

Hall Slim é uma coleção com um perfil compacto e retilíneo que se apresenta em diferentes acabamentos que permitem integrar uma luz de leitura orientável de forma discreta.



Hall Reader

QS



Blanco Branco 14 ○
Negro Preto 05 ●
Oro mate Ouro mate DN ●

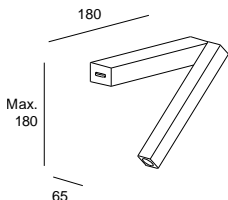

LED | K 2700 | CRI 90 | W Total 3.5 | Real Lm 150



ON-OFF 100-240V

Structure

Code

| | |
|------|---------------|
| 05 ● | 05-8510-05-05 |
| 14 ○ | 05-8510-14-14 |
| DN ● | 05-8510-DN-DN |



QS Quick Service | 2-6 días laborables (tiempo de transporte no incluido)
Quick Service | 2-6 dias úteis (tempo de transporte não incluído)

Gamma



Performance Universe



P. 194



P. 228



P. 264



Posibilidad de instalación empotrado o superficie.
Possibilidade de instalação encastrada ou superfície.

Gamma Round

QS

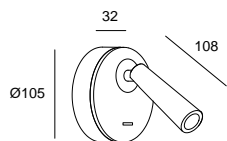
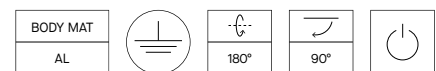

LED | K 2700 | CRI 90 | W Total 3.5 | Real Lm 137



Structure

Code

Blanco Branco 14 ○
Negro Preto 05 ●
Níquel satinado Níquel acetinado 81 ●
Oro mate Ouro mate DN ●

ON-OFF 100-277V

05 ●
14 ○
81 ●
DN ●

05-6421-05-05
05-6421-14-14
05-6421-81-81
05-6421-DN-DN

96 3-35 mm

Gamma Square

QS

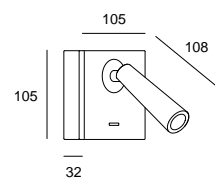
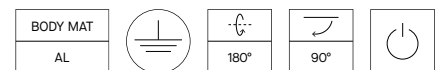

LED | K 2700 | CRI 90 | W Total 3.5 | Real Lm 137



Structure

Code

Blanco Branco 14 ○
Negro Preto 05 ●
Níquel satinado Níquel acetinado 81 ●
Oro mate Ouro mate DN ●

ON-OFF 100-277V

05 ●
14 ○
81 ●
DN ●

05-6420-05-05
05-6420-14-14
05-6420-81-81
05-6420-DN-DN

3-35 mm 96

Gamma Mini



Performance Universe



P. 194



P. 228



P. 264



Gamma Mini

QS

| | | | |
|----------|--|-----|----|
| BODY MAT | | | |
| AL | | 180 | 90 |

Blanco Branco 14

Negro Preto 05

Níquel satinado Níquel acetinado 81

Oro mate Ouro mate DN

LED | K 2700 | CRI 90 | W Total 3.6 | Real Lm 137

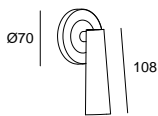

40 3-30 mm



ON-OFF 100-240V

Structure Code

| | |
|----|----------------------|
| 05 | 05-6428-05-05 |
| 14 | 05-6428-14-14 |
| 81 | 05-6428-81-81 |
| DN | 05-6428-DN-DN |

Gamma Extend



Performance Universe



P. 192



P. 228



P. 264



Elegancia y precisión

Gamma Extend conserva toda la esencia de la colección, presentando una silueta moldeada con precisión con un acabado perfecto en todas sus variantes.

Elegância e precisão

Gamma Extend conserva toda a essência da coleção, apresentando uma silhueta moldada com precisão com um acabamento perfeito em todas as suas variantes.

Gamma Extend

QS

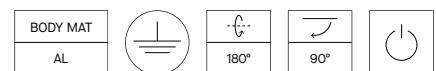

Blanco Branco 14 ○
 Negro Preto 05 ●
 Níquel satinado Níquel acetinado 81 ●
 Oro mate Ouro mate DN ●

LED | K 2700 | CRI 90 | W Total 3.2 | Real Lm 137

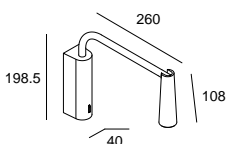

ON-OFF 100-240V

Structure Code

05 ● 05-8339-05-05
 14 ○ 05-8339-14-14
 81 ● 05-8339-81-81
 DN ● 05-8339-DN-DN

Radar



Performance Universe



Radar combina un excelente punto de luz orientable con un diseño minimalista fácilmente integrable en distintos ambientes.

Radar combina um excelente ponto de luz orientável com um design minimalista que pode ser facilmente integrado em diferentes ambientes.



Radar dispone de LCA (Life Cycle Assessment).
O Radar dispõe de LCA (Life Cycle Assessment).

Radar

QS

| | | | |
|----------|---------|--|------|
| BODY MAT | DIF MAT | | |
| AL | PMMA | | 360° |

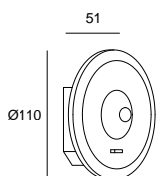

LED | K 3000 | CRI 80 | W Total 6 | Real Lm 150

Blanco Branco 14
Negro Preto 60



Structure

Code

ON-OFF 100-240V

14
60

05-6488-14-14
05-6488-60-60

85 3-30 mm

Pipe



Essential Universe



P. 170



P. 354

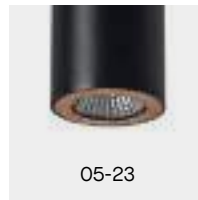

05-23



14-05

Combinaciones standard.
Combinações padrão.



14-14



05-05

Posibilidad de otras combinaciones mediante aros no incluidos.
Possibilidade de outras combinações por aros não incluídos.

Pipe Reader

QS

BODY MAT
ST,AL



Blanco Branco 14 ○
Negro Preto 05 ●

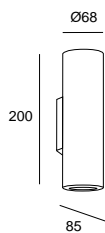

GU10 | W 2 × Max. 8

Structure Ring

14 ○ 05 ●
05 ●* 05 ●*

*Bombilla no incluída.
*Lâmpada não incluída.

Code

05-2759-14-05
05-2759-05-05

Acc. comunes no incluídos

Aro branco
Aro branco

71-0073-14-14

Ac. comuns não incluídos

Aro negro
Aro preto

71-0073-05-05

*Consulte condiciones y plazos de entrega a nuestro equipo comercial.

*Consultar a nossa equipa comercial para informações sobre as condições e os prazos de entrega.

Simply



Essential Universe



P. 230



P. 353



Efectividad en la mínima expresión

Simply ofrece una máxima funcionalidad con la mínima expresión. Esta serie está concebida para perdurar en el tiempo e iluminar cualquier estancia, independientemente de cuál sea su estilo.

Efectividade na mínima expressão

Simply oferece a máxima funcionalidade com a mínima expressão. Esta série foi concebida para perdurar no tempo e iluminar qualquer divisão, independentemente de qual seja o seu estilo.

Simply

QS

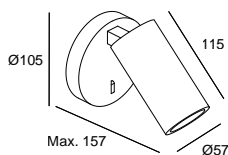
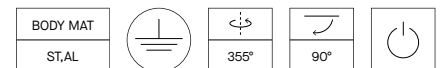

GU10 | W Max. 8

Structure

05 ●
14 ○

*Bombilla no incluída.
*Lâmpada não incluída.

Code

05-7982-05-05
05-7982-14-14

Bianco Branco 14 ○
Negro Preto 05 ●

Stylus



Essential Universe



P. 172



P. 355



Stylus dispone de LCA (Life Cycle Assesment).
O Stylus dispõe de LCA (Life Cycle Assessment).

Stylus Switch

| | | | | |
|----------|---------|------|----------|--|
| BODY MAT | DIF MAT | | | |
| AL | PC | 355° | 0° a 90° | |

LED | K 3000 | CRI 90 | W Total 4.5 | Real Lm 276

Blanco Branco 14 ○
Negro Preto 05 ●

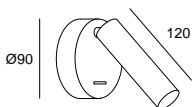

ON-OFF 100-240V

Structure

Code

05 ●
14 ○

05-6193-05-05
05-6193-14-14

Bed



Essential Universe



Bed Round

QS

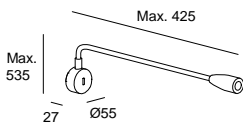
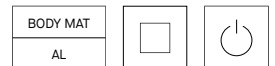

LED | K 3000 | CRI 90 | W Total 3.5 | Real Lm 115

Negro Preto 05 ●



Structure

Code

ON-OFF 100-240V

05 ●

05-2830-05-05

Bed Rectangular

QS

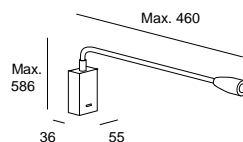
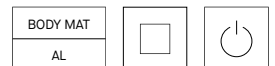

LED | K 3000 | CRI 90 | W Total 3.5 | Real Lm 115

Negro Preto 05 ●



Structure

Code

ON-OFF 100-240V

05 ●

05-2831-05-05

Link



Performance Universe



Opción Touch dimming en el cabezal.
Opção Touch dimming na cabeça.

Un mismo modelo con dos opciones de instalación.
O mesmo modelo com duas opções de instalação.

Link Surface

QS

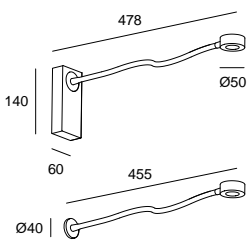

LED | K 2700 | CRI 80 | W Total 4 | Real Lm 121

Blanco Branco 14 ○
Negro Preto 05 ●

| Structure | Code |
|------------------------|----------------------|
| TOUCH DIMMING 100-240V | |
| 05 ● | 05-7366-05-05 |
| 14 ○ | 05-7366-14-14 |

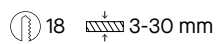

Link Recessed

QS

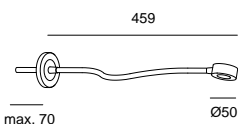
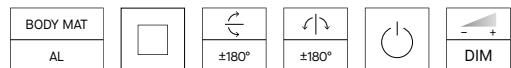

LED | K 2700 | CRI 80 | W Total 4 | Real Lm 121

Blanco Branco 14 ○
Negro Preto 05 ●

| Structure | Code |
|------------------------|----------------------|
| TOUCH DIMMING 100-240V | |
| 05 ● | 05-7367-05-05 |
| 14 ○ | 05-7367-14-14 |

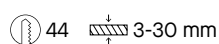

Tip



Performance Universe



Tip

QS

| | | | | | |
|----------|--|-------|-------|--|-----|
| BODY MAT | | | | | |
| AL | | ±180° | ±180° | | DIM |

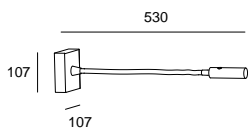

LED | K 3000 | CRI 92 | W Total 4.2 | Real Lm 175

Níquel satinado Níquel acetinado 81
 Oro mate Ouro mate DN



Structure

Code

TOUCH DIMMING 100-240V

81
 DN

05-5296-81-81
 05-5296-DN-DN

Clip



Essential Universe



P. 234



P. 268



Estilo y pureza

Clip es la reinención de un clásico, su leve inclinación aporta un toque fresco al diseño jugando con un punto LED completamente integrado. Es una luminaria funcional gracias a la combinación de pantalla y punto de lectura independiente.

Estilo e pureza

Clip é a reinvenção de um clássico, a sua ligeira inclinação dá um toque de frescura ao design, jogando com um ponto LED completamente integrado. É uma luminária funcional graças à combinação de quebra-luz e ponto de leitura independente.



El lector LED permite una rotación muy amplia para mayor comodidad.

O leitor LED permite uma rotação muito ampla para maior conforto.

Clip

QS

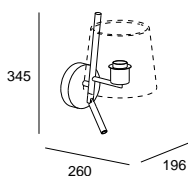
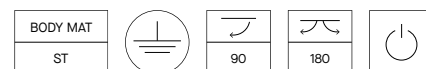

LED+E27 | K 2700 | CRI 92 | Real Lm 53

Negro Preto 05 ●

| | W Total | Structure | Code |
|----------------------------|-----------|-----------|----------------------|
| ON-OFF 100-277V LED E27 | 2.2 15 | 05 ● | 05-8540-05-82 |

*Bombilla no incluida.
*Lâmpada não incluída.

Acc. comunes no incluidos y requeridos

Ac. comuns não incluído e requeridos



14 ○

05 ●

PAN-232-14

PAN-232-05

Metrica



Essential Universe



P. 236



P. 270



P. 313



Un clásico con múltiples opciones

Metrica es una solución perfecta gracias a sus múltiples posibilidades de luz de pantalla, punto de lectura y flexo. Con un diseño actual y sobrio es una colección altamente versátil.

Um clássico com várias opções

Metrica é uma solução perfeita graças às suas múltiplas possibilidades de quebra-luz, ponto de leitura e braço articulado. Com um design atual e sóbrio, é uma coleção muito versátil.



Metrica Shade Reader

QS

| | | | | | |
|-------------------|----------------|--|---------|---------|--------|
| BODY MAT ST,AL | DIF MAT TEX | | 180 | 90° | x2 |
|-------------------|----------------|--|---------|---------|--------|

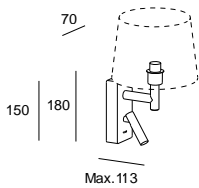

LED+E27 | K 2700 | CRI 92 | Real Lm 137

Negro Preto 05 ●
Níquel satinado Níquel acetinado 81 ●

| | | W Total | Structure | Code |
|-----------------|---------|-----------|--------------|--|
| ON-OFF 100-240V | LED E27 | 2.1 15 | 05 ● 81 ● | 05-8400-05-82 05-8400-81-82 |

*Bombilla no incluida.
*Lâmpada não incluida.

QS Quick Service | 2-6 días laborables (tiempo de transporte no incluido)
Quick Service | 2-6 dias úteis (tempo de transporte não incluido)



Metrica Extended

QS

| | | | | | |
|----------|---------|--|--|--|--|
| BODY MAT | DIF MAT | | | | |
| ST,AL | TEX | | | | |

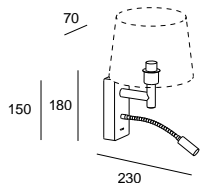

LED+E27 | K 2700 | CRI 92 | Real Lm 137

Negro Preto 05
Níquel satinado Níquel acetinado 81

| | W Total | Structure | Code |
|-----------------|------------|-----------|--|
| ON-OFF 100-240V | LED E27 | 2.1 15 | 05 81 |
| | | | 05-8401-05-82 05-8401-81-82 |

*Bombilla no incluida.
*Lâmpada não incluida.

QS Quick Service | 2-6 días laborables (tiempo de transporte no incluido)
Quick Service | 2-6 días úteis (tempo de transporte não incluido)

No incluidos y requeridos Não incluido e requeridos

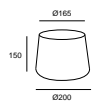

14
05
BY

PAN-157-14
PAN-157-05
PAN-157-BY

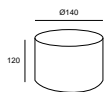

14
BY

PAN-175-14
PAN-175-BY

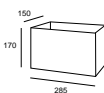

14
BY

PAN-176-14
PAN-176-BY

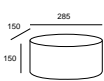

14
BY

PAN-177-14
PAN-177-BY

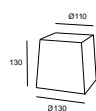

14
BY

PAN-178-14
PAN-178-BY

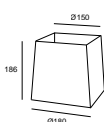

14
BY

PAN-179-14
PAN-179-BY



Sobremesa

De mesa



Dara

210



Levels

212



llargi

218



Tubs

222



H

216



Perlina

220



Maca

224



Invisible

226



Gamma

228



Organic

229



Simply

230



Nude

231



Clip

234



Metrica

236

Dara NEW



Essential Universe



Simplicidad, funcionalidad y versatilidad

Dara destaca por su originalidad y minimalismo, ofreciendo una iluminación general cuando se coloca en posición vertical y una luz más focalizada al inclinarla. Gracias a un simple gesto en la base, permite ajustarse fácilmente a dos posiciones: una pensada para crear una luz ambiente suave y otra ideal para trabajar o leer con mayor precisión.

Simplicidade, funcionalidade e versatilidade

Dara distingue-se pela sua originalidade e minimalismo, oferecendo uma iluminação geral quando colocada na vertical e uma luz mais focada quando inclinada. Graças a um simples gesto na base, pode ser facilmente ajustada em duas posições: uma pensada para criar uma luz ambiente suave e outra ideal para trabalhar ou ler com maior precisão.

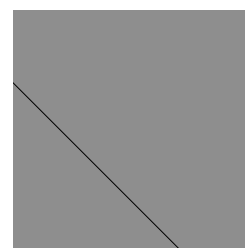



Base metálica con un corte frontal que facilita la inclinación de la lámpara para obtener una iluminación más focalizada si se desea.

Diseño esencial en dos elementos —parte lumínica y base— con un corte frontal que permite inclinar la lámpara para obtener luz focal.

Base metálica com um corte frontal que facilita a inclinação da lâmpada para obter uma iluminação mais focada, se desejado.

Design essencial em dois elementos – parte lumínica e base – com um corte frontal que permite inclinar o candeeiro para obter luz focal.

Cabezal de líneas depuradas y difusor de diseño preciso, que garantizan una estética elegante y un acabado de alta calidad.

Un gesto simple que la distingue, con un cabezal depurado y un difusor elegante que aportan versatilidad y carácter.

Cabeça de linhas depuradas e um difusor de design preciso garantem uma estética elegante e um acabamento de alta qualidade.

Um gesto simples que a distingue, com uma cabeça depurada e um difusor elegante que conferem versatilidade e carácter.



Dara

QS

| | | | |
|----------|---------|--|-----|
| BODY MAT | DIF MAT | | |
| ST: AL | PMMA | | 45° |

Negro Preto 05 ●
Arena Areia FF ●

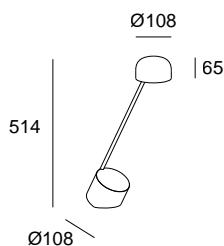

LED | K SW 2700-3000 | CRI 92 | W Total 10.2 | Real Lm 506 (3000K)



ON-OFF 220-240V

Structure

05 ●
FF ●

Code

10-A009-05-05

10-A009-FF-FF

Levels



Performance Universe



P. 086

P. 250

P. 328



Convivencia natural con el entorno

Cada espacio requiere un lenguaje concreto, marcado por la personalidad del ambiente. Las distintas formas y transparencias de las pantallas de Levels sobremesa buscan una convivencia natural con su entorno integrándose tanto a nivel de acabado como de efecto de luz gracias a la transparencia de su vidrio soplado de forma artesanal

Convivência natural com o meio ambiente

Cada espaço requer uma linguagem específica, marcada pela personalidade do ambiente. As diferentes formas e transparências do as quebra-luces de Levels de mesa procuram uma coexistência natural com o seu ambiente, integrando-se tanto em termos de acabamento como de efeito de luz graças à transparência do seu vidro soprado de forma artesanal.





Levels 1 Body Ø220mm

QS

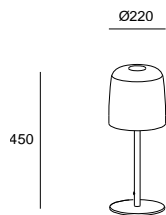

| | | | |
|----------|---------|------------|----------------|
| BODY MAT | DIF MAT | SWITCH CCT | 2700-3000-4000 |
| ST | GLA | | |

| | | |
|-------------|----|---|
| Negro Preto | 05 | ● |
| Verde Verde | 08 | ● |
| Fumé Fumado | 12 | ● |
| Ámbar Âmbar | 15 | ● |

LED | K 2700-3000-4000 | CRI 92 | W Total 14.7 | Real Lm 1069 (3000K)

| | Structure | Difussor | Code |
|--------------------------|-----------|----------|----------------------|
| 3 STEPS DIMMING 100-240V | 05 ● | 08 ● | 10-A002-05-08 |
| | 05 ● | 12 ● | 10-A002-05-12 |
| | 05 ● | 15 ● | 10-A002-05-15 |

Levels 1 Body Ø320mm

QS

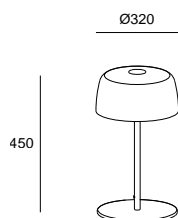

| | | | |
|----------|---------|------------|----------------|
| BODY MAT | DIF MAT | SWITCH CCT | 2700-3000-4000 |
| ST | GLA | | |

| | | |
|-------------|----|---|
| Negro Preto | 05 | ● |
| Verde Verde | 08 | ● |
| Fumé Fumado | 12 | ● |
| Ámbar Âmbar | 15 | ● |

LED | K 2700-3000-4000 | CRI 92 | W Total 14.7 | Real Lm 1069 (3000K)

| | Structure | Difussor | Code |
|--------------------------|-----------|----------|----------------------|
| 3 STEPS DIMMING 100-240V | 05 ● | 08 ● | 10-A003-05-08 |
| | 05 ● | 12 ● | 10-A003-05-12 |
| | 05 ● | 15 ● | 10-A003-05-15 |

Levels 1 Body Ø420mm

QS

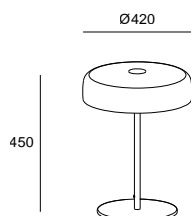

| | | | |
|----------|---------|------------|----------------|
| BODY MAT | DIF MAT | SWITCH CCT | 2700-3000-4000 |
| ST | GLA | | |

| | | |
|-------------|----|---|
| Negro Preto | 05 | ● |
| Verde Verde | 08 | ● |
| Fumé Fumado | 12 | ● |
| Ámbar Âmbar | 15 | ● |

LED | K 2700-3000-4000 | CRI 92 | W Total 14.7 | Real Lm 1069 (3000K)

| | Structure | Difussor | Code |
|--------------------------|-----------|----------|----------------------|
| 3 STEPS DIMMING 100-240V | 05 ● | 08 ● | 10-A004-05-08 |
| | 05 ● | 12 ● | 10-A004-05-12 |
| | 05 ● | 15 ● | 10-A004-05-15 |

Levels Table Lamps 2 Bodies

QS

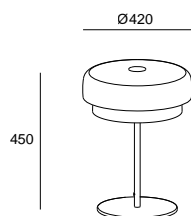

| | | | |
|----------|---------|------------|----------------|
| BODY MAT | DIF MAT | SWITCH CCT | 2700-3000-4000 |
| ST | GLA | | |

| | | |
|-------------|----|---|
| Negro Preto | 05 | ● |
| Verde Verde | 08 | ● |
| Fumé Fumado | 12 | ● |
| Ámbar Âmbar | 15 | ● |

LED | K 2700-3000-4000 | CRI 92 | W Total 14.7 | Real Lm 1069 (3000K)

| | Structure | Difussor | Code |
|--------------------------|-----------|----------|----------------------|
| 3 STEPS DIMMING 100-240V | 05 ● | 08 ● | 10-A005-05-08 |
| | 05 ● | 12 ● | 10-A005-05-12 |
| | 05 ● | 15 ● | 10-A005-05-15 |

Los acabados y tonalidad mostrados pueden no ser completamente precisos debido a ligeras variaciones en la producción, factores de iluminación fotográficas e impresión.

Os acabamentos e tonalidades apresentados podem não ser totalmente precisos, devido a ligeiras variações na produção, fatores de iluminação fotográfica e de impressão.

H



Performance Universe



P. 140



P. 258



P. 306



Elegancia innata

La colección de luminarias H nace como una reinterpretación contemporánea del clásico sobremesa de pantalla cónica. La versatilidad de la colección permite iluminar diferentes espacios de forma delicada, mediante piezas que aportan un gran valor representativo.

Elegância inata

A coleção de luminárias H nasce como uma reinterpretação contemporânea do clássico de mesa de quebra-luz cônico. A versatilidade da coleção permite iluminar diferentes espaços de forma delicada, mediante peças que proporcionam um grande valor representativo.

H

QS

| |
|----------|
| BODY MAT |
| ST |

| |
|---------|
| DIF MAT |
| ACR |

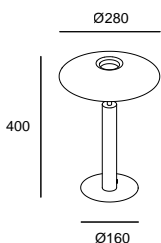

LED | K 2700 | CRI 92 | W Total 16.3 | Real Lm 627

ON-OFF 220-240V

Structure

05 ●
DN ●

Code

10-7742-05-05
10-7742-DN-DN

Negro Preto 05 ●
Oro mate Ouro mate DN ●



Ilargi



Performance Universe



P. 092



Base de madera maciza con acabado en fresno o negro y difusor de cristal opal.
Base de madeira maciça com acabamento em freixo ou preto e difusor de vidro opalino.

La calidez de un diseño atemporal

Ilargi, creada por los diseñadores vascos Irtzoki y Lizaso, es una combinación perfecta de calidez y diseño funcional atemporal. Su cristal de vidrio soplado de manera artesanal tiene una presencia muy elegante, que se combina con madera noble maciza. Su luz es suave y agradable, perfecta para uso residencial o para espacios públicos creando ambientes confortables y naturales.

A calidez de um design intemporal

Ilargi, criada pelos designers bascos Irtzoki e Lizaso, é uma combinação perfeita de calidez e design funcional intemporal. A sua campânula de vidro soprado de forma artesanal tem uma presença muito elegante, que é combinada com a madeira nobre maciça. A sua luz é suave e agradável, perfeita para uso residencial ou para espaços públicos criando ambientes confortáveis e naturais.



Con Touch Dimming.
Com Touch Dimming.

Ilargi Ø230

| | | | |
|----------|---------|--|--|
| BODY MAT | DIF MAT | | |
| WOOD | GLA | | |

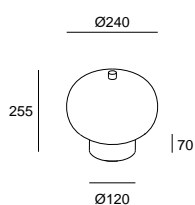

LED | K 2700 | CRI 92 | W Total 10.5 | Real Lm 641

Fresno oscuro Cinza escura 92 ●
Fresno claro Cinza claro 93 ●
Arenado Areado F9 ○

| | Structure | Difussor | Code |
|------------------------|--------------|--------------|--|
| TOUCH DIMMING 100-240V | 92 ● 93 ● | F9 ○ F9 ○ | 10-6010-92-F9 10-6010-93-F9 |

Ilargi Ø320

| | | | |
|----------|---------|--|--|
| BODY MAT | DIF MAT | | |
| WOOD | GLA | | |

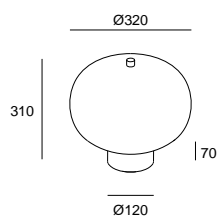

LED | K 2700 | CRI 92 | W Total 16.4 | Real Lm 1054

Fresno oscuro Cinza escura 92 ●
Fresno claro Cinza claro 93 ●
Arenado Areado F9 ○

| | Structure | Difussor | Code |
|------------------------|--------------|--------------|--|
| TOUCH DIMMING 100-240V | 92 ● 93 ● | F9 ○ F9 ○ | 10-6011-92-F9 10-6011-93-F9 |

Perlina



Performance Universe



Joya natural

Este sobremesa juega con una doble función, por un lado, el de la practicidad de una luminaria práctica con una luz difusa muy agradable y por el otro, como un objeto de decoración delicado y elegante que puede integrarse fácilmente en cualquier ambiente. Además, Perlina permite crear diferentes ambientes gracias a su regulación dimable.

Joia natural

Este candeeiro de mesa tem uma função dupla: por um lado, a praticidade de uma luminária prática com uma luz difusa muito agradável e, por outro lado, como um objeto decorativo delicado e elegante que pode ser facilmente integrado em qualquer ambiente. Além disso, Perlina permite criar diferentes ambientes graças à sua regulação dimmable.

Perlina

QS

| | | | | | |
|---------------------|----------------|--|------------------------------|--|-------|
| BODY MAT AISI304 | DIF MAT GLA | | SWITCH CCT 2700-3000-4000 | | USB C |
|---------------------|----------------|--|------------------------------|--|-------|

Negro Preto 60 ●
Oro mate Ouro mate DN ●

LED | K 2700-3000-4000 | CRI 92 | W Total 8.8 | Real Lm 391 (3000K)



TOUCH DIMMING 220-240V

Structure Code

60 ● 10-A078-60-60
DN ● 10-A078-DN-DN

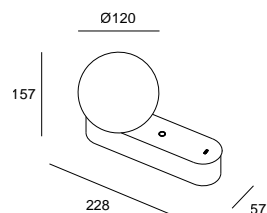



Tubs



Performance Universe



P. 260



P. 289



Presencia y dinamismo

Tubs es un sobremesa con una fuente de luz en forma lineal que tiene una amplia capacidad de movimientos, lo que ofrece un gran dinamismo a la pieza y dota de carácter el espacio que habita. Sofisticada y elegante, con una base en mármol negro, puede regularse mediante touch dimming, adaptándose a las necesidades lumínicas de cada momento.

Presença e dinamismo

Tubs é uma versão de mesa com uma fonte de luz em forma linear que possui uma ampla capacidade de movimento, oferecendo um grande dinamismo à peça e conferindo caráter ao espaço que habita. Sofisticada e elegante, com uma base em mármore preto, pode ser regulada mediante touch dimming, adaptando-se às necessidades lumínicas de cada momento.



Base en mármol.
Base de mármore.



Con Touch Dimming.
Com Touch Dimming.

Tubs

QS

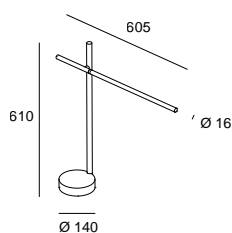

LED | CRI 92 | W Total 9.5

Negro Preto 05 ●
Blanco opal Branco opalino M1 ○

| | K | Real Lm | Structure | Difusor | Code |
|---------------------------|--------------|------------|--------------|--------------|--|
| TOUCH DIMMING 220-240V | 2700 3000 | 479 504 | 05 ● 05 ● | M1 ○ M1 ○ | 10-A026-05-M1 10-8102-05-M1 |

Maca



Performance Universe



Funcionalidad y comodidad

Maca ha sido creada como una herramienta de trabajo confortable tanto en su forma, de mecánica y tacto suave, como en su función, ya que proporciona una luz asimétrica con unas prestaciones técnicas muy elevadas, con un buen pack lumínico y opción de 3 temperaturas de color dimables a través de un único botón touch.

Funcionalidade e comodidade

Maca foi criada como uma ferramenta de trabalho confortável, tanto na sua forma, de mecânica e toque suave, como na sua função, já que proporciona uma luz assimétrica com um desempenho técnico muito elevado, com um bom pack lumínico e opção de 3 temperaturas de cor reguláveis através de um único botão touch.



Maca

QS

| | | | | | |
|----------|---------|--|----------------|------|-----|
| BODY MAT | DIF MAT | | SWITCH CCT | | |
| ST | ACR | | 2700-3000-4000 | 355° | 90° |

Blanco texturizado Branco texturizado DQ
 Negro texturizado Preto texturizado DI

LED | K 2700-3000-4000 | CRI 80 | W Total 9 | Real Lm 587 (3000K)



Structure

Code

TOUCH DIMMING 220-240V

DI
DQ

10-9055-DI-DI
10-9055-DQ-DQ

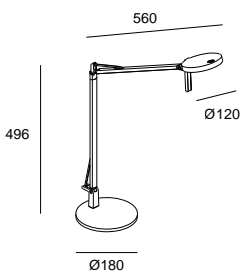

QS Quick Service | 2-6 días laborables (tiempo de transporte no incluido)
 Quick Service | 2-6 dias úteis (tempo de transporte não incluído)

Invisible



Performance Universe



P. 151



P. 184



P. 262



P. 292



Movimiento en equilibrio

Francesc Vilaró se ha inspirado en los móviles del escultor Alexander Calder para diseñar la colección, buscando el equilibrio entre las líneas que forman la estructura y su contrapeso. En esta composición de balances, la luz puede dirigirse a cualquier punto, proyectando una luz de acento de forma muy honesta, con una gran libertad de movimientos.

Movimento em equilíbrio

Francesc Vilaró inspirou-se nos móveis do escultor Alexander Calder para criar a coleção, procurando um equilíbrio entre as linhas que formam a estrutura e o seu contrapeso. Nesta composição de equilíbrios, a luz pode ser dirigida para qualquer ponto, projetando uma luz de realce de uma forma muito honesta, com uma grande liberdade de movimentos.





La rotación del cabezal permite dirigir la luz.
A rotação da cabeça permite dirigir a luz.

Invisible

QS

| | | | | | | |
|----------|---------|--|------|------|------|--|
| BODY MAT | DIF MAT | | | | | |
| ST,AL | PMMA | | 355° | 355° | ±90° | |

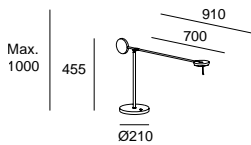

LED | CRI 92

Negro Preto 05 ●

| | K | W Total | Real Lm | Structure | Code |
|---------------|------|---------|---------|-----------|----------------------|
| TOUCH DIMMING | 2700 | | 496 | 05 ● | 10-7385-05-05 |
| 100-240V | 3000 | | 550 | 05 ● | 10-5693-05-05 |

Gamma



Performance Universe

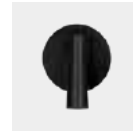

P. 192



P. 194



P. 264



Diseño minimalista contemporáneo

Con un diseño contemporáneo y minimalista, Gamma es una solución de luz para escritorio con cualidades técnicas y decorativas que la convierten en una opción siempre acertada.

Design minimalista contemporâneo

Com um design contemporâneo e minimalista, Gama é uma solução de iluminação de secretária com qualidades técnicas e decorativas que a tornam uma excelente escolha.

Botón de encendido en la base.
Botão de ligar/desligar na base.



Gamma

QS



- Blanco Branco 14 ○
- Negro Preto 05 ●
- Níquel satinado Níquel acetinado 81 ●
- Oro mate Ouro mate DN ●

LED | K 2700 | CRI 92 | W Total 4.3 | Real Lm 293



Structure

Code

ON-OFF 100-240V

- 05 ●
- 14 ○
- 81 ●
- DN ●

- 10-6420-05-05**
- 10-6420-14-14**
- 10-6420-81-81**
- 10-6420-DN-DN**

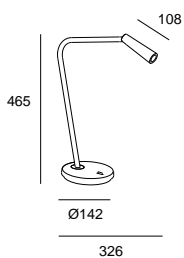

Organic



Performance Universe



P. 253



P. 308



Inspiración orgánica

El perfil de esta pieza, suave y armónica, se inspira en las formas orgánicas de las flores y las hojas. Su pantalla ligeramente curvada, con un interior dorado, se integra en el espacio de sutil y natural.

Inspiração orgânica

O perfil desta peça, suave e harmónica, é inspirado nas formas orgânicas das flores e folhas. O seu quebra-luz ligeiramente curvo, com um interior dourado, integra-se no espaço de forma subtil e natural.

Organic

QS

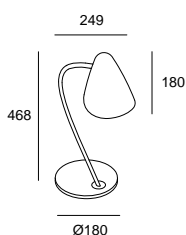
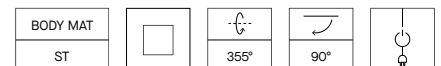

E27 Max. L 120 mm - Ø 80 mm | W Max. 15

Negro Preto 05 ●

Structure

Code

05 ●

10-7582-05-05

*Bombilla no incluída.
*Lâmpada não incluída.

Simply



Essential Universe



P. 197



P. 353



Diseño minimalista contemporáneo

Con un diseño contemporáneo y minimalista, Simply es una solución de luz para escritorio con cualidades técnicas y decorativas que la convierten en una opción siempre acertada.

Design minimalista contemporâneo

Com um design contemporâneo e minimalista, Simply é uma solução de iluminação de secretária com qualidades técnicas e decorativas que a tornam uma excelente escolha.

Simply

QS

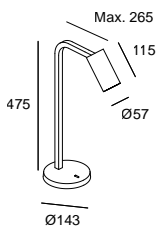
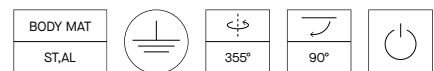

GU10 | W Max. 8

Structure

- 05 ●
- 14 ○

*Bombilla no incluída.
*Lâmpada não incluída.

- Blanco Branco 14 ○
- Negro Preto 05 ●

Code

10-7982-05-05
10-7982-14-14

Incluido
Incluído

Panel de abeja
Favo de abelha

Nude



Essential Universe



P. 265



P. 312



Diseño contemporáneo

El diseño contemporáneo de Nude se basa en la simplicidad de las formas y en destacar la belleza de la bombilla, que toma el protagonismo en esta amplia colección. La versión sobremesa incluye distintas posibilidades de instalación, lo que enriquece aún más la familia.

Design contemporâneo

O design contemporâneo de Nude baseia-se na simplicidade das formas e em destacar a beleza da lâmpada, que ocupa o lugar central nesta ampla coleção. A versão de mesa inclui diferentes possibilidades de instalação, o que enriquece ainda mais a família.







05



DN

Nude Curved

QS

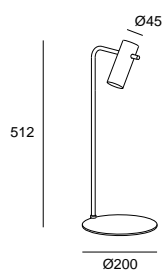
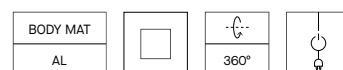

E27 120 mm or 95 mm Opal or Vintage finishing | W Max. 15

Negro Preto 05 ●
Oro mate Ouro mate DN ●

| Structure | Head | Code |
|-----------|------|---------------|
| 05 ● | 05 ● | 10-8518-05-05 |
| 05 ● | DN ● | 10-8518-05-DN |

*Bombilla no incluída.
*Lâmpada não incluída.

Nude Tiny

QS

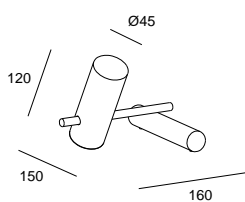
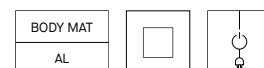

E27 120 mm or 95 mm Opal or Vintage finishing | W Max. 15

Negro Preto 05 ●
Oro mate Ouro mate DN ●

| Structure | Head | Code |
|-----------|------|---------------|
| 05 ● | 05 ● | 10-8516-05-05 |
| 05 ● | DN ● | 10-8516-05-DN |

*Bombilla no incluída.
*Lâmpada não incluída.

Clip



Essential Universe



P. 202



P. 268



Colección de aplique, sobremesa y pie de salón que, basándose en un diseño clásico, se destaca con un plus de contemporaneidad marcado por la forma inclinada de su estructura.

Coleção de aplique, mesa e candeeiro de pé que, com base num design clássico, se destaca com um plus de contemporaneidade marcado pela forma inclinada da sua estrutura.



Opción de pantalla blanca y negra.
Opção de quebra-luz branco e preto.

Clip

QS

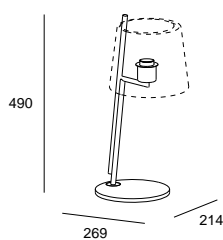

E27 | W Max. 15

Negro Preto 05 ●

Structure

Code

05 ●

10-8540-05-82

*Bombilla no incluída.
*Lâmpada não incluída.

Acc. comunes no incluidos y requeridos

Ac. comuns não incluído e requeridos

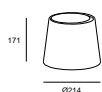

14 ○

PAN-233-14

05 ●

PAN-233-05

Metrica



Essential Universe



P. 204



P. 270



P. 313





Botón de encendido en la parte superior de la tija.

Botão de ligar/desligar na parte superior do espigão.



Opción de base redonda o cuadrada y acabos negro o níquel.

Opção de base redonda ou quadrada e acabamentos a preto ou níquel.

Metrica Round

QS

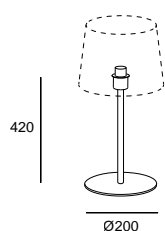

E27 | W Max. 15

Negro Preto 05 ●
Níquel satinado Níquel acetinado 81 ●

Structure

Code

05 ●
81 ●

10-4759-05-82

10-4759-81-82

*Bombilla no incluida.
*Lâmpada não incluida.

Metrica Square

QS

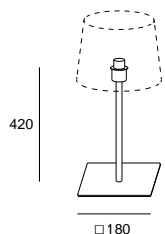
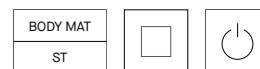

E27 | W Max. 15

Negro Preto 05 ●
Níquel satinado Níquel acetinado 81 ●

Structure

Code

05 ●
81 ●

10-8350-05-82

10-8350-81-82

*Bombilla no incluida.
*Lâmpada não incluida.

QS Quick Service | 2-6 días laborables (tiempo de transporte no incluido)
Quick Service | 2-6 dias úteis (tempo de transporte não incluido)

No incluidos y requeridos

Não incluido e requeridos

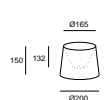

14 ○ PAN-157-14
05 ● PAN-157-05
BY ● PAN-157-BY

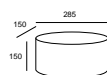

14 ○ PAN-177-14
BY ● PAN-177-BY

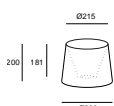

14 ○ PAN-161-14
BY ● PAN-161-BY

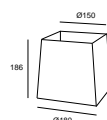

14 ○ PAN-179-14
BY ● PAN-179-BY

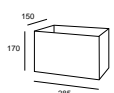

14 ○ PAN-176-14
BY ● PAN-176-BY

Portátil

Portátil



Portobello

244



Cocktail

240

Cocktail



Performance Universe



Icónica y sugerente

Cocktail es una pieza icónica galardonada con el iF Design Awards. Francesc Vilaró se basa en el equilibrio, la industrialización, la innovación y la estética para crear una lámpara portátil que genera atmósferas adaptables a cada necesidad, gracias a su cabezal orientable y a la regulación de dimming con cuatro niveles de intensidad lumínica.

Icônico e sugestivo

Cocktail é uma peça icônica galardoada com o iF Design Awards. Francesc Vilaró baseia-se no equilíbrio, industrialização, inovação e estética para criar um candeeiro portátil que gera atmosferas adaptáveis a cada necessidade graças à sua cabeça ajustável e à regulação de dimming com quatro níveis de intensidade lumínica.









O5



EX

Cocktail

QS

| | | | | | | |
|----------|---------|--|------|-----|--|-------|
| BODY MAT | DIF MAT | | | | | |
| AL | PC | | 350° | 60° | | USB C |

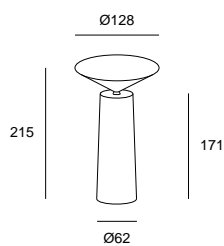

LED | K 2700 | CRI 92 | W Total 3.5 | Real Lm 154

Negro Preto O5 ●
Gris oliva Cinzento oliva EX ●



Structure

Code

TOUCH DIMMING 100-240V

O5 ●
EX ●

10-8327-05-05
10-8327-EX-EX

Incluido
Incluído

Cargador
Carregador

No incluido
Não incluído

Cargador múltiple
Carregador múltiplo

71-8332-05-00

Portobello



Essential Universe



La sofisticación del color

Inspirada en la corriente pop art de los años 60 y 70, Portobello aporta un toque de color y sofisticación a ambientes muy diversos, que lo único que tienen en común es la ausencia de normas. Ligera y resistente, sus formas redondeadas la convierten en una pieza icónica, cercana y acogedora. En acabados estándar blanco y negro, la personalización de la pieza permite un número infinito de acabados para una integración total en cualquier espacio.

A sofisticação da cor

Inspirada no movimento Pop Art dos anos 60 e 70, Portobello fornece um toque de cor e sofisticação a uma grande variedade de ambientes, em que a única coisa que têm em comum é a ausência de regras. Leve e resistente, as suas formas arredondadas tornam-na uma peça icónica, próxima e acolhedora. Em acabamentos standard branco e preto, a personalização da peça permite um número infinito de acabamentos para uma integração total em qualquer espaço.





Acabado personalizable mediante petición.
Acabamento personalizável através de pedido.



Boton touch dimmer con 3 intensidades.
Botão touch dimmer com três intensidades.



Carga mediante USB-C.
Carregamento via USB-C.

Portobello

QS

| | | | | | |
|----------|---------|--|----|--|--|
| BODY MAT | DIF MAT | | IP | | |
| ABS | PMMA | | 44 | | |

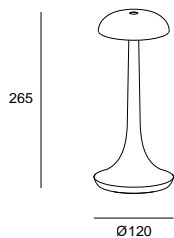

LED | K 2700 | CRI 92 | W Total 2.1 | Real Lm 137

Blanco Branco 14

Negro Preto 05



TOUCH DIMMING 5VDC 1000mA

Structure

Code

05

14

10-A001-05-05

10-A001-14-14

Incluido
Incluído

Cable del cargador
Cabo do carregador

No incluido
Não incluído

Cargador múltiple
Carregador múltiplo

71-8332-05-00

Pie Pé



Levels

250



Perlina

254



Noway

256



H

258



Tubs

260



Invisible

262



Organic

253



Nude

265



Gamma

264



Clip

268



Metrica

270

Levels



Performance Universe



P. 086



P. 212



P. 328



Porte elegante

De porte elegante y presencia destacada, el pie de la colección Levels puede componerse con opción individual o doble, en un juego de sensaciones gracias a las tonalidades del vidrio y las diferentes temperaturas de color, a elegir mediante el switch integrado en el cabezal del LED.

Porte elegante

Com um aspeto elegante e uma presença excecional, o candeeiro de pé da coleção Levels pode ser composto com opção individual ou dupla, num jogo de sensações graças às tonalidades do vidro e às diferentes temperaturas de cor, a escolher através de switch integrado na cabeça do LED.





Vidrios con transparencias del 30% en el difusor pequeño, del 50% en el mediano y del 70% en el grande.
 Vidros com transparências de 30% no difusor pequeno, de 50% no médio e de 70% no grande.

Levels 1 Body Ø420mm

QS

| | | | |
|----------|---------|----------------|--|
| BODY MAT | DIF MAT | SWITCH CCT | |
| ST | GLA | 2700-3000-4000 | |

- Negro Preto 05 ●
- Verde Verde 08 ●
- Fumé Fumado 12 ●
- Âmbar Âmbar 15 ●

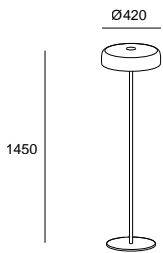

LED | K 2700-3000-4000 | CRI 92 | W Total 17 | Real Lm 750 (3000K)

| | Structure | Difussor | Code |
|---------------|-----------|----------|----------------------|
| PUSH 220-240V | 05 ● | 08 ● | 25-A001-05-08 |
| | 05 ● | 12 ● | 25-A001-05-12 |
| | 05 ● | 15 ● | 25-A001-05-15 |

Levels 2 Bodies Ø420mm + Ø320mm

QS

| | | | |
|----------|---------|----------------|--|
| BODY MAT | DIF MAT | SWITCH CCT | |
| ST | GLA | 2700-3000-4000 | |

- Negro Preto 05 ●
- Verde Verde 08 ●
- Fumé Fumado 12 ●
- Âmbar Âmbar 15 ●

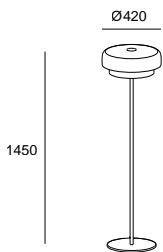

LED | K 2700-3000-4000 | CRI 92 | W Total 17 | Real Lm 750 (3000K)

| | Structure | Difussor | Code |
|---------------|-----------|----------|----------------------|
| PUSH 220-240V | 05 ● | 08 ● | 25-A002-05-08 |
| | 05 ● | 12 ● | 25-A002-05-12 |
| | 05 ● | 15 ● | 25-A002-05-15 |

*Los acabados y tonalidad mostrados pueden no ser completamente precisos debido a ligeras variaciones en la producción, factores de iluminación, fotográficas e impresión.

*Os acabamentos e tonalidades apresentados podem não ser totalmente precisos, devido a ligeiras variações na produção, fatores de iluminação fotográfica e de impressão.

Organic



Performance Universe



P. 229



P. 308



El perfil de esta pieza, suave y armónica, se inspira en las formas orgánicas de las flores y las hojas. Su pantalla ligeramente curvada, con un interior dorado, se integra en el espacio de forma sutil y natural.

O perfil desta peça, suave e harmónica, é inspirado nas formas orgânicas das flores e folhas. O seu quebra-luz ligeiramente curvo, com um interior dourado, integra-se no espaço de forma subtil e natural.

Luz dirigitible gracias a la rotación de sus ejes.
Luz direccionável graças à rotação dos seus eixos.

Organic

QS

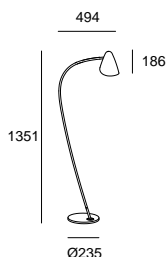

E27 | W Max. 15

Negro Preto 05 ●

Structure

05 ●

Code

25-7582-05-05

*Bombilla no incluida.
*Lâmpada não incluída.

Perlina



Performance Universe



P. 182



P. 220



P. 276



P. 358



Joya natural

Las tres esferas iluminadas de Perlina, distribuidas sobre su estructura lineal, permite ofrecer una luz cálida y agradable para aquellas zonas dónde se necesita mayor intensidad de luz de manera elegante. Aquí la fuerza de lo simple cobra todo el sentido en un juego entre la geometría del círculo y la pureza de la verticalidad.

Joia natural

As três esferas iluminadas de Perlina, distribuídas na sua estrutura linear, oferecem uma luz quente e agradável para as áreas onde é necessária uma maior intensidade de luz de uma forma elegante. Aqui, a força da simplicidade assume todo o seu significado num jogo entre a geometria do círculo e a pureza da verticalidade.



Perlina

QS

| | | | | |
|----------|---------|---|----------------|---|
| BODY MAT | DIF MAT | □ | SWITCH CCT | ⚡ |
| ST | GLA | | 2700-3000-4000 | |

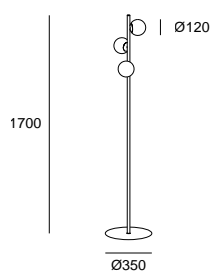

LED | K 2700-3000-4000 | CRI 92 | W Total 22.9 | Real Lm 1172 (3000K)

Negro Preto 60 ●
Oro mate Ouro mate DN ●



Structure

Code

ON-OFF 220-240V

60 ●
DN ●

25-A076-60-60
25-A076-DN-DN

Noway



Performance Universe



P. 124



Suspensión

De presencia rotunda y protagonista, Noway incorpora un nuevo pie de salón ajustable con pértiga que se adueña del espacio con una sofisticación innata. Con diseño de doble pantalla, su efecto de luz es acogedor y confortable a partes iguales. Noway destaca de forma natural por sus cualidades estéticas y técnicas, convirtiéndose sin disimulo en el centro de atención de todas las miradas.

Suspensão

Com uma presença enfática e protagonista, Noway incorpora um novo candeeiro de pé ajustável com um grande braço que toma conta do espaço com uma sofisticação inata. Com design de duplo quebra-luz, o seu efeito de luz é acolhedor e confortável em partes iguais. Noway destaca-se de forma natural pelas suas qualidades estéticas e técnicas, convertendo-se sem dissimular no centro das atenções de todos os olhares.



La pantalla del nivel inferior siempre con acabado negro.
O quebra-luz do nivel inferior sempre com acabamento preto.

Noway Big

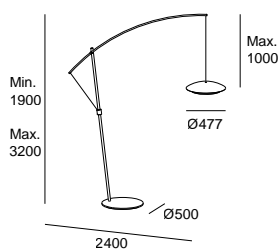
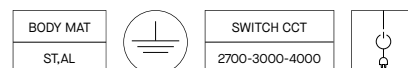

LED | K 2700-3000-4000 | CRI 92 | W Total 25.4 | Real Lm 813 (3000K)

Negro Preto 05 ●

| | Upper Screen | Lower Screen | Structure | Code |
|-----------------|--------------|--------------|-----------|-------------------------|
| PUSH 220-240V | 05 ● | 05 ● | 05 ● | 25-8566-05-05 |
| ON-OFF 220-240V | 05 ● | 05 ● | 05 ● | 25-8394-05-05 QS |

Acc. comunes incluidos
Ac. comuns incluídos

Clip regulación altura
Clipe regulação altura

H



Performance Universe



P. 140



P. 216



P. 306

**Belleza atemporal**

La colección de luminarias H nace como una reinterpretación contemporánea del clásico sobremesa de pantalla cónica. La versatilidad de la colección permite iluminar diferentes espacios de forma delicada, mediante piezas que aportan un gran valor representativo.

Elegância inata

A coleção de luminárias H nasce como uma reinterpretação contemporânea do clássico de mesa de quebra-luz cônico. A versatilidade da coleção permite iluminar diferentes espaços de forma delicada, mediante peças que proporcionam um grande valor representativo.



H

QS

| | | | |
|----------|---------|--|--|
| BODY MAT | DIF MAT | | |
| ST | ACR | | |

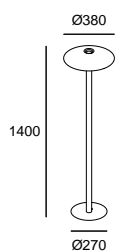

LED | K 2700 | CRI 92 | W Total 277 | Real Lm 1328

Negro Preto 05 ●
Oro mate Ouro mate DN ●



Structure

Code

ON-OFF 220-240V

05 ●
DN ●

25-7742-05-05
25-7742-DN-DN

QS Quick Service | 2-6 días laborables (tiempo de transporte no incluido)
Quick Service | 2-6 dias úteis (tempo de transporte não incluído)

Tubs



Performance Universe



P. 222



P. 289



Presencia y dinamismo

Tubs es un pie de salón con una fuente de luz en forma lineal que tiene una amplia capacidad de movimientos, lo que ofrece un gran dinamismo a la pieza y dota de carácter el espacio que habita. Sofisticada y elegante, con base de mármol, puede regularse mediante touch dimming, adaptándose a las necesidades lumínicas de cada momento con una destacada presencia.

Presencia y dinamismo

Tubs é um candeeiro de pé com uma fonte de luz em forma linear que apresenta uma ampla capacidade de movimentos, o que confere grande dinamismo à peça dotando de carácter o espaço que habita. Sofisticada e elegante, com uma base em mármore preto, pode ser regulada mediante touch dimming, adaptando-se às necessidades lumínicas de cada momento com uma presença marcante.



Tubs

QS

| | | | | | | |
|-----------|---------|--|------|-------|------|-----|
| BODY MAT | DIF MAT | | | | | |
| ST,AL,MAR | PC | | 360° | 0-90° | 360° | DIM |

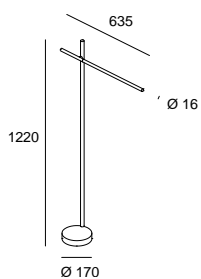

LED | CRI 92 | W Total 9.5

Negro Preto 05 ●
Blanco opal Branco opalino M1 ○

| | K | Real Lm | Structure | Difussor | Code |
|------------------------|--------------|------------|--------------|--------------|--|
| TOUCH DIMMING 220-240V | 2700 3000 | 479 504 | 05 ● 05 ● | M1 ○ M1 ○ | 25-A026-05-M1 25-8102-05-M1 |

QS Quick Service | 2-6 días laborables (tiempo de transporte no incluido)
Quick Service | 2-6 dias úteis (tempo de transporte não incluído)

Invisible



Performance Universe



P. 151



P. 184



P. 226

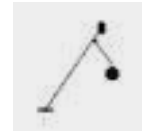

P. 292



Movimiento en equilibrio

Francesc Vilaró se inspiró en los móviles del escultor Alexander Calder para diseñar la colección Invisible, buscando el equilibrio entre las líneas que forman la estructura y el círculo que las une haciendo de contrapeso. En esta composición de balances, la luz puede dirigirse a cualquier punto, proyectando una luz de acento de forma muy honesta, con una gran libertad de movimientos en todas sus versiones. Invisible es una pieza icónica que ha recibido el premio German Design Award.

Movimento em equilíbrio

Francesc Vilaró inspirou-se nos móveis do escultor Alexander Calder para criar a coleção Invisible, procurando um equilíbrio entre as linhas que formam a estrutura e o círculo que as une como contrapeso. Nesta composição de equilíbrios, a luz pode ser dirigida para qualquer ponto, projetando uma luz de realce de uma forma muito honesta, com uma grande liberdade de movimentos em todas as suas versões. Invisible é uma peça icónica que recebeu o German Design Award.





La rotación del cabezal permite dirigir la luz.

A rotação da cabeça permite dirigir a luz.

Invisible

QS

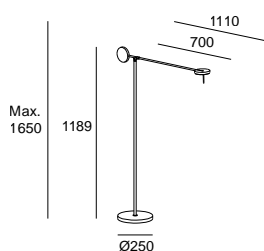

| | | | | | | |
|----------|---------|--|------|------|------|--|
| BODY MAT | DIF MAT | | | | | |
| ST,AL | PMMA | | 355° | 355° | ±90° | |

LED | CRI 92 | W Total 10,5

Negro Preto 05 ●

| | K | Real Lm | Structure | Code |
|---------------------------|--------------|------------|--------------|--|
| TOUCH DIMMING 100-240V | 2700 3000 | 534 550 | 05 ● 05 ● | 25-7385-05-05 25-5693-05-05 |

Gamma



Performance Universe

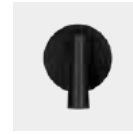

P. 192



P. 194



P. 228



La opción pie de salón se presenta como una versión muy minimalista que convive con naturalidad en los ambientes que habita.

A opção de pé apresenta-se como uma versão muito minimalista que convive com naturalidade nos ambientes que habita.

Rotación tanto del cabezal como de su eje.
Rotação tanto da cabeça como do seu eixo.

Gamma

QS

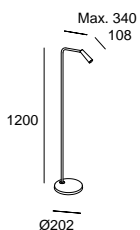
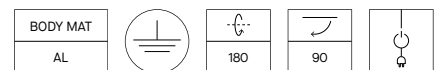

LED | K 2700 | CRI 92 | W Total 4.3 | Real Lm 293

Negro Preto 05 ●
Oro mate Ouro mate DN ●



ON-OFF 100-240V

Structure

Code

05 ●
DN ●

25-6420-05-05
25-6420-DN-DN

Nude



Essential Universe



P. 231



P. 312



Diseño contemporáneo

El diseño contemporáneo de Nude se basa en la simplicidad de las formas y en destacar la belleza de la bombilla, que toma el protagonismo en esta amplia colección. La versión pie de salón incluye la opción de tres estructuras distintas.

Design contemporâneo

O design contemporâneo de Nude baseia-se na simplicidade das formas e em destacar a beleza da lâmpada, que ocupa o lugar central nesta ampla coleção. A versão de candeeiro de chão inclui a opção de três estruturas diferentes.



Incluye gomas para ajustar el cableado.
Inclui borrachas para ajustar a cablagem.



05



DN

Nude Single

QS

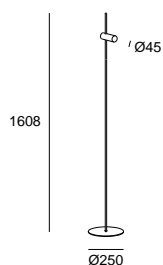
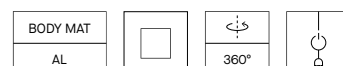

E27 | W Max. 15

Negro Preto 05 ●
Oro mate Ouro mate DN ●

| Structure | Head | Code |
|-----------|------|---------------|
| 05 ● | 05 ● | 25-8520-05-05 |
| 05 ● | DN ● | 25-8520-05-DN |

*Bombilla no incluída.
*Lâmpada não incluída.

Nude Curved

QS

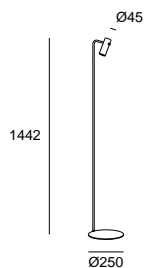
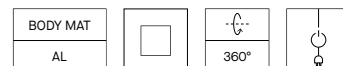

E27 | W Max. 15

Negro Preto 05 ●
Oro mate Ouro mate DN ●

| Structure | Head | Code |
|-----------|------|---------------|
| 05 ● | 05 ● | 25-8522-05-05 |
| 05 ● | DN ● | 25-8522-05-DN |

*Bombilla no incluída.
*Lâmpada não incluída.

Nude Double

QS

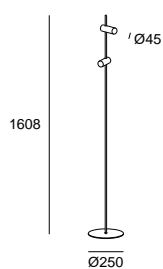
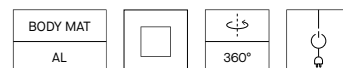

E27 | W 2 × Max. 15

Negro Preto 05 ●
Oro mate Ouro mate DN ●

| Structure | Head | Code |
|-----------|------|---------------|
| 05 ● | 05 ● | 25-8521-05-05 |
| 05 ● | DN ● | 25-8521-05-DN |

*Bombilla no incluída.
*Lâmpada não incluída.

Clip



Essential Universe



P. 202



P. 234



Colección de aplique, sobremesa y pie de salón que, basándose en un diseño clásico, se destaca con un plus de contemporaneidad marcado por la forma inclinada de su estructura.

Coleção de aplique, mesa e candeeiro de pé que, com base num design clássico, se destaca com um plus de contemporaneidade marcado pela forma inclinada da sua estrutura.





Clip

QS

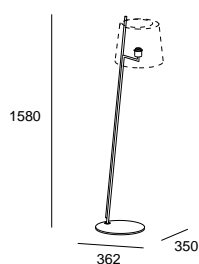

E27 | W Max. 15

Negro Preto 05 ●

Structure

Code

05 ●

25-8540-05-82

*Bombilla no incluida.
*Lâmpada não incluída.

No incluidos y requeridos
Não incluído e requeridos

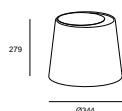

14 ○

05 ●

PAN-234-14

PAN-234-05

Metrica



Essential Universe

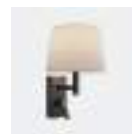

P. 204



P. 236



P. 313





Opción de base redonda o cuadrada y acabos negro o níquel.
Opção de base redonda ou quadrada e acabamentos a preto ou níquel.

Metrica Round

QS

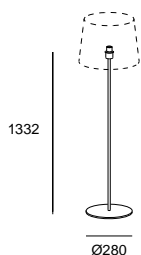

E27 | W Max. 15

Structure

05 ●
81 ●

*Bombilla no incluída.
*Lâmpada não incluída.

Code

25-4759-05-82
25-4759-81-82

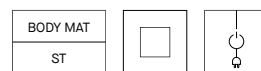

Negro Preto 05 ●
Níquel satinado Níquel acetinado 81 ●

Metrica Square

QS

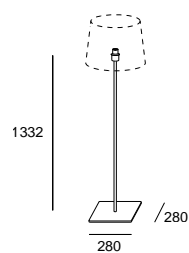

E27 | W Max. 15

Structure

05 ●
81 ●

*Bombilla no incluída.
*Lâmpada não incluída.

Code

25-8350-05-82
25-8350-81-82

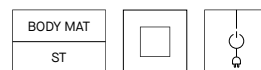

Negro Preto 05 ●
Níquel satinado Níquel acetinado 81 ●

No incluidos y requeridos

Não incluído e requeridos

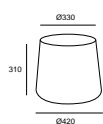

14 ○ PAN-159-14
BY ● PAN-159-BY

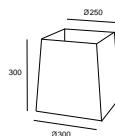

BY ● PAN-181-BY

Superficie de pared

Superfície de parede



Spark

278



Perlina

276



Trip Glass

286



Trip

281



Bloom

288



Tubs

289



Invisible

292



Veneto

298



Prolix

294

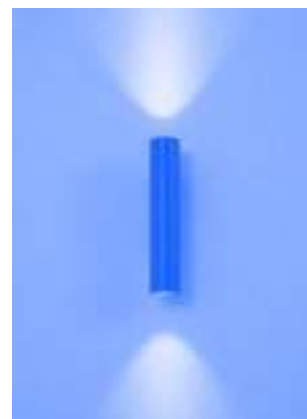

Linea

296



Big Bang

299



Attic

300



Super Attic

304



Organic

308



H

306



Drone

310



Miso

309



Nude

312



Vetro

311



Metrica

313



Lia

317



Fino

314



Duna 316



Lia LED 318



Mini 320



Wilson 323



Cut 322



Ges Circular 325



Ges 324

Perlina



Performance Universe



P. 182



P. 220



P. 254



P. 358



Joya natural

Perlina se inspira en una joya natural para ofrecer una perla iluminada que juega con la esencia de la circunferencia, redonda y perfecta, dando sentido al minimalismo de lo básico. Cuando está encendida, su efecto de luz tamizada transmite un sentimiento de calma llenando el espacio con naturalidad y acomodándose a él gracias a la posibilidad de regulación manual mediante dimmer.

Joia natural

Perlina inspira-se numa joia natural para oferecer uma pérola iluminada que brinca com a essência da circunferência, redonda e perfeita, dando sentido ao minimalismo do básico. Quando acesa, o seu efeito de luz filtrada transmite uma sensação de calma, preenchendo naturalmente o espaço e adaptando-se a ele graças à possibilidade de regulação manual através de dimmer.



Perlina IP44

QS

| | | | | |
|----------|---------|--|----|----------------|
| BODY MAT | DIF MAT | | IP | SWITCH CCT |
| AISI304 | GLA | | 44 | 2700-3000-4000 |

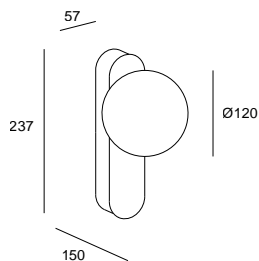

LED | K 2700-3000-4000 | CRI 92 | W Total 8.8 | Real Lm 391 (3000K)

Negro Preto 60 ●
Oro mate Ouro mate DN ●



Structure Code

ON-OFF 220-240V

60 ● **05-A076-60-60**
DN ● **05-A076-DN-DN**

DALI-2 220-240V

60 ● **05-A077-60-60**
DN ● **05-A077-DN-DN**

Spark



Performance Universe



P. 340



Inspiración nórdica

De inspiración nórdica, la sencillez de los elementos encuentra su razón de ser en la perfección de las formas y en sus combinaciones. Con distintas posibilidades de composición Spark propone un juego de volúmenes que se combinan alrededor de un perfil que pasa prácticamente desapercibido. Diseñada sin ataduras, sus posibilidades de instalación responden a su misma esencia de libertad.

Inspiração nórdica

De inspiração nórdica, a simplicidade dos elementos encontra a sua razão de ser na perfeição das formas e nas suas combinações. Com diferentes possibilidades de composição Spark propõe um jogo de volumes que se combinam em torno de um perfil que passa praticamente despercebido. Concebida sem laços, as suas possibilidades de instalação respondem à sua própria essência de liberdade.



Los tres cuerpos lumínicos generan tres volúmenes diferenciados.

Os três corpos lumínicos geram três volumes diferenciados.

Spark Single Ø140mm

| | | | |
|----------|---------|---|----------------|
| BODY MAT | DIF MAT |  | SWITCH CCT |
| ST | GLA | | 2700-3000-4000 |

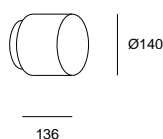

LED | K 2700-3000-4000 | CRI 92 | W Total 10 | Real Lm 424 (3000K)

Negro Preto 05 ●
Arenado Areado F9 ○

| | Structure | Difussor | Code |
|---|--------------------|----------|----------------------|
|  | PHASE CUT 220-240V | 05 ● | F9 ○ |
| | | | 15-A125-05-F9 |

Spark Single Ø240mm

| | | | |
|----------|---------|---|----------------|
| BODY MAT | DIF MAT |  | SWITCH CCT |
| ST | GLA | | 2700-3000-4000 |

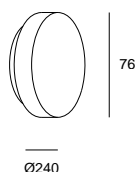

LED | K 2700-3000-4000 | CRI 92 | W Total 16 | Real Lm 652 (3000K)

Negro Preto 05 ●
Arenado Areado F9 ○

| | Structure | Difussor | Code |
|---|--------------------|----------|----------------------|
|  | PHASE CUT 220-240V | 05 ● | F9 ○ |
| | | | 15-A126-05-F9 |

Spark Single Ø390mm

| | | | |
|----------|---------|---|----------------|
| BODY MAT | DIF MAT |  | SWITCH CCT |
| ST | GLA | | 2700-3000-4000 |

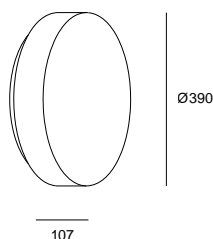

LED | K 2700-3000-4000 | CRI 92 | W Total 43.7 | Real Lm 2083 (3000K)

Negro Preto 05 ●
Arenado Areado F9 ○

| | Structure | Difussor | Code |
|---|---------------|----------|----------------------|
|  | DALI 220-240V | 05 ● | F9 ○ |
| | | | 15-A127-05-F9 |

Spark Double Ø390mm + Ø140mm

| |
|----------|
| BODY MAT |
| ST |

| |
|---------|
| DIF MAT |
| GLA |



| |
|----------------|
| SWITCH CCT |
| 2700-3000-4000 |

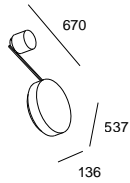

LED | K 2700-3000-4000 | CRI 92 | W Total 53.5 | Real Lm 2507 (3000K)

Negro Preto 05 ●
Arenado Areado F9 ○



| | Structure | Difussor | Code |
|---------------|-----------|----------|---------------|
| DALI 220-240V | 05 ● | F9 ○ | 15-A128-05-F9 |

Spark Double Ø390mm + Ø240mm

| |
|----------|
| BODY MAT |
| ST |

| |
|---------|
| DIF MAT |
| GLA |



| |
|----------------|
| SWITCH CCT |
| 2700-3000-4000 |

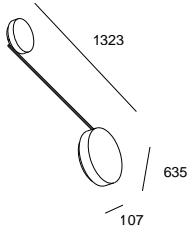

LED | K 2700-3000-4000 | CRI 92 | W Total 60.5 | Real Lm 2735 (3000K)

Negro Preto 05 ●
Arenado Areado F9 ○



| | Structure | Difussor | Code |
|---------------|-----------|----------|---------------|
| DALI 220-240V | 05 ● | F9 ○ | 15-A129-05-F9 |

Spark Triplex Ø390mm + Ø240mm + Ø140mm

| |
|----------|
| BODY MAT |
| ST |

| |
|---------|
| DIF MAT |
| GLA |



| |
|----------------|
| SWITCH CCT |
| 2700-3000-4000 |

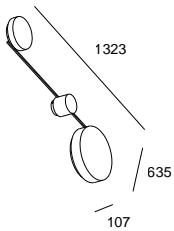

LED | K 2700-3000-4000 | CRI 92 | W Total 68.5 | Real Lm 3159 (3000K)

Negro Preto 05 ●
Arenado Areado F9 ○



| | Structure | Difussor | Code |
|---------------|-----------|----------|---------------|
| DALI 220-240V | 05 ● | F9 ○ | 15-A130-05-F9 |



Desarrollado de forma minuciosa para conseguir un vidrio de calidad y un perfil muy fino con las mejores prestaciones técnicas.

Desenvolvido de forma minuciosa para conseguir um vidro de qualidade e um perfil muito fino com as melhores prestações técnicas.

Trip



Performance Universe



Versátil e imaginativa

Trip es un aplique pensado para decorar paredes con su sola presencia, marcada por el entramado en rejilla de su cuerpo metálico, sus posibilidades de combinación, ya sea simple, doble o triple con distintos acabados y el efecto que proporciona su punto de luz suave, difuso y asimétrico.

Versátil e imaginativo

Trip é um candeeiro de parede concebido para decorar paredes com a sua mera presença, marcada pela moldura quadriculada do seu corpo metálico, pelas suas possibilidades de combinação, sejam elas simples, duplas ou triplas com diferentes acabamentos e pelo efeito proporcionado pela sua fonte de luz suave, difusa e assimétrica.

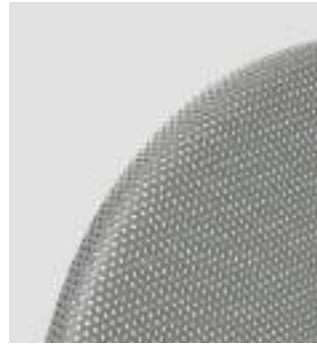



Trip 300mm

QS

| | | |
|----------|---------|--|
| BODY MAT | DIF MAT | |
| ST,AL | GLA | |

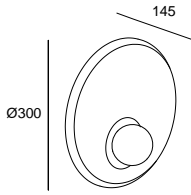

E14 Max. L 90 mm - Ø 50 mm | W Max. 9

Negro Preto 05 ●
Oro mate Ouro mate DN ●

| Structure | Small | Code |
|-----------|-------|----------------------|
| 05 ● | 05 ● | 05-8356-05-05 |
| 05 ● | DN ● | 05-8356-05-DN |

Acabados The Colours bajo pedido mínimo de 15 unidades. Consultar precios en tarifa y plazos de entrega con equipo comercial.
Acabamentos The Colours sujeitos a encomenda mínima de 15 unidades. Consultar preços e prazos de entrega com a nossa equipa comercial.

Structure: 05 ● Negro Preto Small: 14 ○ Blanco Branco
05 ● Negro Preto EM ● Gris piedra Cinzento pedra

Trip 460mm

QS

| | | |
|----------|---------|--|
| BODY MAT | DIF MAT | |
| ST,AL | GLA | |

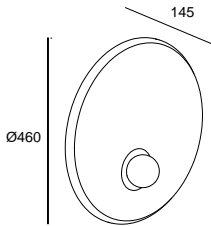

E14 Max. L 90 mm - Ø 50 mm | W Max. 9

Negro Preto 05 ●
Oro mate Ouro mate DN ●

| Structure | Big | Code |
|-----------|------|----------------------|
| 05 ● | 05 ● | 05-8357-05-05 |
| 05 ● | DN ● | 05-8357-05-DN |

Acabados The Colours bajo pedido mínimo de 15 unidades. Consultar precios en tarifa y plazos de entrega con equipo comercial.
Acabamentos The Colours sujeitos a encomenda mínima de 15 unidades. Consultar preços e prazos de entrega com a nossa equipa comercial.

Structure: 05 ● Negro Preto Big: 14 ○ Blanco Branco
05 ● Negro Preto EM ● Gris piedra Cinzento pedra

Trip Double 535mm

QS

| | | |
|----------|---------|--|
| BODY MAT | DIF MAT | |
| ST,AL | GLA | |

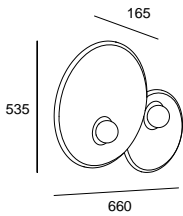

E14 Max. L 90 mm - Ø 50 mm | W 2 × Max. 9

Negro Preto 05 ●
Oro mate Ouro mate DN ●

| Structure | Small | Big | Code |
|-----------|-------|------|----------------------|
| 05 ● | 05 ● | 05 ● | 05-8359-05-05 |
| 05 ● | DN ● | DN ● | 05-8359-05-DN |
| 05 ● | 05 ● | DN ● | 05-8359-05-DP |

Acabados The Colours bajo pedido mínimo de 15 unidades. Consultar precios en tarifa y plazos de entrega con equipo comercial.
Acabamentos The Colours sujeitos a encomenda mínima de 15 unidades. Consultar preços e prazos de entrega com a nossa equipa comercial.

Structure: 05 ● Negro Preto Small: 14 ○ Blanco Branco Big: 14 ○ Blanco Branco
05 ● Negro Preto EM ● Gris piedra Cinzento pedra EM ● Gris piedra Cinzento pedra

Trip Double 650mm

QS

| | | |
|----------|---------|--|
| BODY MAT | DIF MAT | |
| ST,AL | GLA | |

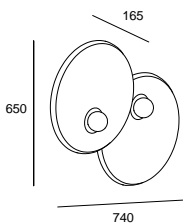

E14 Max. L 90 mm - Ø 50 mm | W 2 × Max. 9

Negro Preto 05 ●
Oro mate Ouro mate DN ●

| Structure | Big | Big | Code |
|-----------|------|------|----------------------|
| 05 ● | 05 ● | 05 ● | 05-8360-05-05 |
| 05 ● | DN ● | DN ● | 05-8360-05-DN |
| 05 ● | 05 ● | DN ● | 05-8360-05-DP |

Acabados The Colours bajo pedido mínimo de 15 unidades. Consultar precios en tarifa y plazos de entrega con equipo comercial.
Acabamentos The Colours sujeitos a encomenda mínima de 15 unidades. Consultar preços e prazos de entrega com a nossa equipa comercial.

Structure: 05 ● Negro Preto Big: 14 ○ Blanco Branco Big: 14 ○ Blanco Branco
05 ● Negro Preto EM ● Gris piedra Cinzento pedra EM ● Gris piedra Cinzento pedra

Trip Double 420mm

QS

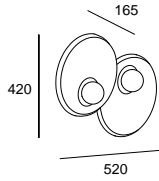

| | | |
|----------|---------|--|
| BODY MAT | DIF MAT | |
| ST,AL | GLA | |

E14 Max. L 90 mm - Ø 50 mm | W 2 × Max. 9

 Negro Preto 05 ●
 Oro mate Ouro mate DN ●

| Structure | Small | Small | Code |
|-----------|-------|-------|----------------------|
| 05 ● | 05 ● | 05 ● | 05-8361-05-05 |
| 05 ● | DN ● | DN ● | 05-8361-05-DN |
| 05 ● | 05 ● | DN ● | 05-8361-05-DP |

Acabados The Colours bajo pedido mínimo de 15 unidades. Consultar precios en tarifa y plazos de entrega con equipo comercial.
 Acabamentos The Colours sujeitos a encomenda mínima de 15 unidades. Consultar preços e prazos de entrega com a nossa equipa comercial.

Structure: 05 ● Negro Preto **Small:** 14 ○ Blanco Branco **Small:** 14 ○ Blanco Branco
 05 ● Negro Preto EM ● Gris piedra Cinzento pedra EM ● Gris piedra Cinzento pedra

Trip Triple 650mm

QS

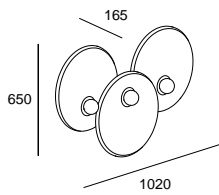

| | | |
|----------|---------|--|
| BODY MAT | DIF MAT | |
| ST,AL | GLA | |

E14 Max. L 90 mm - Ø 50 mm | W 3 × Max. 9

 Negro Preto 05 ●
 Oro mate Ouro mate DN ●

| Structure | Big | Big | Big | Code |
|-----------|------|------|------|----------------------|
| 05 ● | 05 ● | 05 ● | 05 ● | 05-8362-05-05 |
| 05 ● | DN ● | DN ● | DN ● | 05-8362-05-DN |
| 05 ● | DN ● | 05 ● | DN ● | 05-8362-05-DP |

Acabados The Colours bajo pedido mínimo de 15 unidades. Consultar precios en tarifa y plazos de entrega con equipo comercial.
 Acabamentos The Colours sujeitos a encomenda mínima de 15 unidades. Consultar preços e prazos de entrega com a nossa equipa comercial.

Structure: 05 ● Negro Preto **Big:** 14 ○ Blanco Branco **Big:** 14 ○ Blanco Branco **Big:** 14 ○ Blanco Branco
 05 ● Negro Preto EM ● Gris piedra Cinzento pedra EM ● Gris piedra Cinzento pedra EM ● Gris piedra Cinzento pedra

Trip Triple 535mm

QS

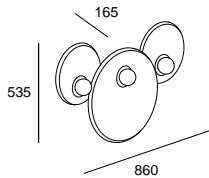

| | | |
|----------|---------|--|
| BODY MAT | DIF MAT | |
| ST,AL | GLA | |

E14 Max. L 90 mm - Ø 50 mm | W 3 × Max. 9

 Negro Preto 05 ●
 Oro mate Ouro mate DN ●

| Structure | Small | Big | Small | Code |
|-----------|-------|------|-------|----------------------|
| 05 ● | 05 ● | 05 ● | 05 ● | 05-8363-05-05 |
| 05 ● | DN ● | DN ● | DN ● | 05-8363-05-DN |
| 05 ● | DN ● | 05 ● | DN ● | 05-8363-05-DP |

Acabados The Colours bajo pedido mínimo de 15 unidades. Consultar precios en tarifa y plazos de entrega con equipo comercial.
 Acabamentos The Colours sujeitos a encomenda mínima de 15 unidades. Consultar preços e prazos de entrega com a nossa equipa comercial.

Structure: 05 ● Negro Preto **Small:** 14 ○ Blanco Branco **Big:** 14 ○ Blanco Branco **Small:** 14 ○ Blanco Branco
 05 ● Negro Preto EM ● Gris piedra Cinzento pedra EM ● Gris piedra Cinzento pedra EM ● Gris piedra Cinzento pedra

Trip Glass



Performance Universe



Diseño clásico y orgánico

El óvalo de vidrio soplado de forma artesanal rodea la fuente de luz creando un agradable efecto luminoso. Trip Glass es un aplique clásico con una personalidad atemporal, que se presenta en dos tonalidades, ambar y fumé.

Design clássico e orgânico

El oval de vidro soprado de forma artesanal envolve a fonte de luz criando um efeito luminoso muito agradável. Trip Glass é um aplique clássico com uma personalidade intemporal, disponível em duas tonalidades, âmbar e fumado.



Tonalidad ámbar al 30%.
Matiz ámbar a 30%.



Tonalidad fumé al 50%.
Matiz fumê a 50%.

Trip Glass

QS

| | | |
|----------|---------|--|
| BODY MAT | DIF MAT | |
| AL | GLA | |

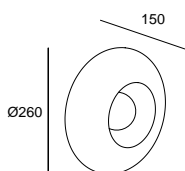

E14 Max. L 90 mm - Ø 50 mm | W Max. 9

Negro Preto 05 ●
Fumé Fumado 12 ●
Ámbar Âmbar 15 ●

| Structure | Body | Code |
|-----------|------|----------------------|
| 05 ● | 12 ● | 05-8358-05-12 |
| 05 ● | 15 ● | 05-8358-05-15 |

*Los acabados y tonalidad mostrados pueden no ser completamente precisos debido a ligeras variaciones en la producción, factores de iluminación, fotográficas e impresión.

*Os acabamentos e tonalidades apresentados podem não ser totalmente precisos, devido a ligeiras variações na produção, fatores de iluminação fotográfica e de impressão.

Bloom



Essential Universe



P. 360



Diseño amable y sencillez de las formas

La sencillez y la funcionalidad son a menudo la mejor carta de presentación. Bloom tiene un diseño amable, equilibrado en las formas, que la hacen destacar en el espacio precisamente por la suavidad de su perfil. Su desarrollo técnico, con un IP44 certificado, la convierten en una luminaria muy versátil para diferentes ambientes.

Design amigável e simplicidade de formas

A simplicidade e a funcionalidade são muitas vezes a melhor carta de apresentação. Bloom tem um design afável, equilibrado nas formas, o que a fazem sobressair devido à suavidade do seu perfil. O seu desenvolvimento técnico torna-a uma luminária muito versátil para diferentes ambientes, graças ao seu IP44.

Superfície de pared | Superfície de parede

Decorative Collection

288

Bloom

QS

| | | | |
|----------|---------|--|----|
| BODY MAT | DIF MAT | | IP |
| ST | GLA | | 44 |

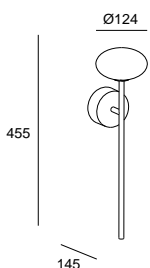

LED | K 2700 | CRI 92 | W Total 7.5 | Real Lm 262

Negro Preto 05 ●

ON-OFF 100-277V

Structure Code

05 ● 05-A011-05-M1

QS Quick Service | 2-6 días laborables (tiempo de transporte no incluido)
Quick Service | 2-6 dias úteis (tempo de transporte não incluido)

Tubs



Performance Universe



P. 222



P. 260

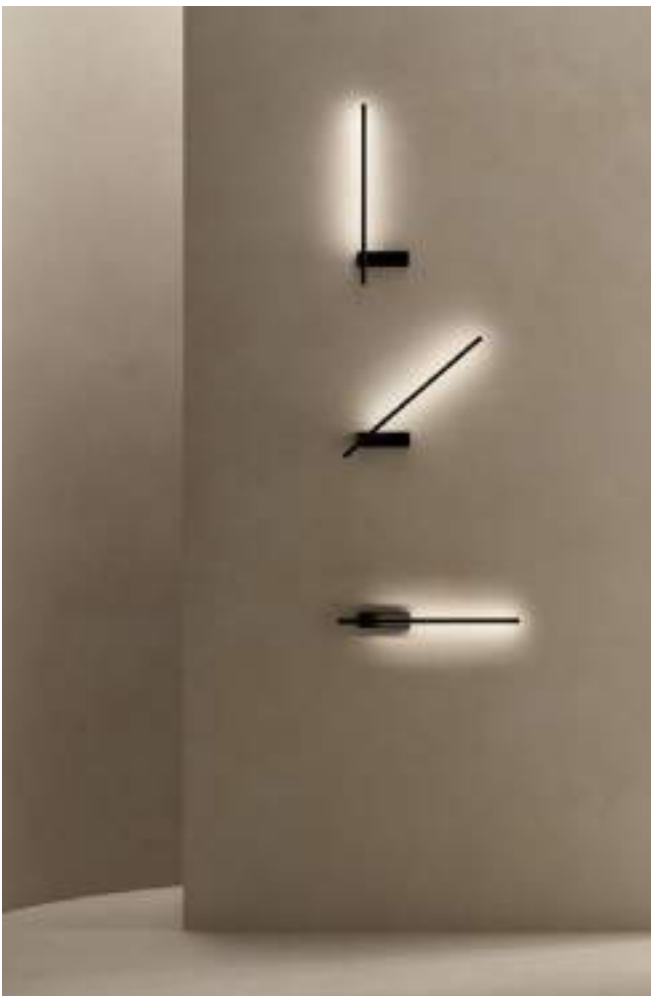

Presencia y dinamismo

Tubs es un diseño Deco Tech que presenta la luz a través de tramos rectos y orientables. Tubs aplique puede rotar tanto desde su difusor, dirigiendo el haz de luz donde sea preciso, como desde su eje, con orientación sobre sus diferentes ejes longitudinales.

Presença e dinamismo

Tubs é um design Deco Tech que apresenta a luz através de secções retas e orientáveis. A luminária de parede Tubs pode girar tanto a partir de seu difusor, direcionando o feixe de luz para onde for necessário, quanto a partir de seu eixo, com orientação em seus diferentes eixos longitudinais.





Amplia capacidad de movimientos: el difusor puede rotarse 360°, al mismo tiempo que la rótula del brazo.
 Grande amplitude de movimentos: o difusor pode rodar 360°, ao mesmo tempo que a junta esférica do braço.

Tubs

| | | | | | |
|----------|---------|--|------|-------|-------|
| BODY MAT | DIF MAT | | | | |
| ST,AL | PC | | 360° | 0-90° | 0-90° |

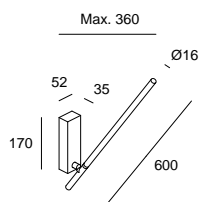

LED | CRI 92 | W Total 8.4

Negro Preto 05 ●
 Blanco opal Branco opalino M1 ○

| | K | Real Lm | Structure | Difusor | Code |
|-----------------|------|---------|-----------|---------|-------------------------|
| ON-OFF 220-240V | 2700 | 506 | 05 ● | M1 ○ | 05-A026-05-M1 QS |
| 0-10V 120-277V | 2700 | 506 | 05 ● | M1 ○ | 05-A028-05-M1 |
| DALI-2 220-240V | 2700 | 506 | 05 ● | M1 ○ | 05-A027-05-M1 |
| ON-OFF 220-240V | 3000 | 471 | 05 ● | M1 ○ | 05-8102-05-M1 QS |
| 0-10V 120-240V | 3000 | 471 | 05 ● | M1 ○ | 05-8104-05-M1 |
| DALI-2 220-240V | 3000 | 471 | 05 ● | M1 ○ | 05-8103-05-M1 |

Invisible



Performance Universe



P. 151



P. 184

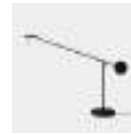

P. 226



P. 262

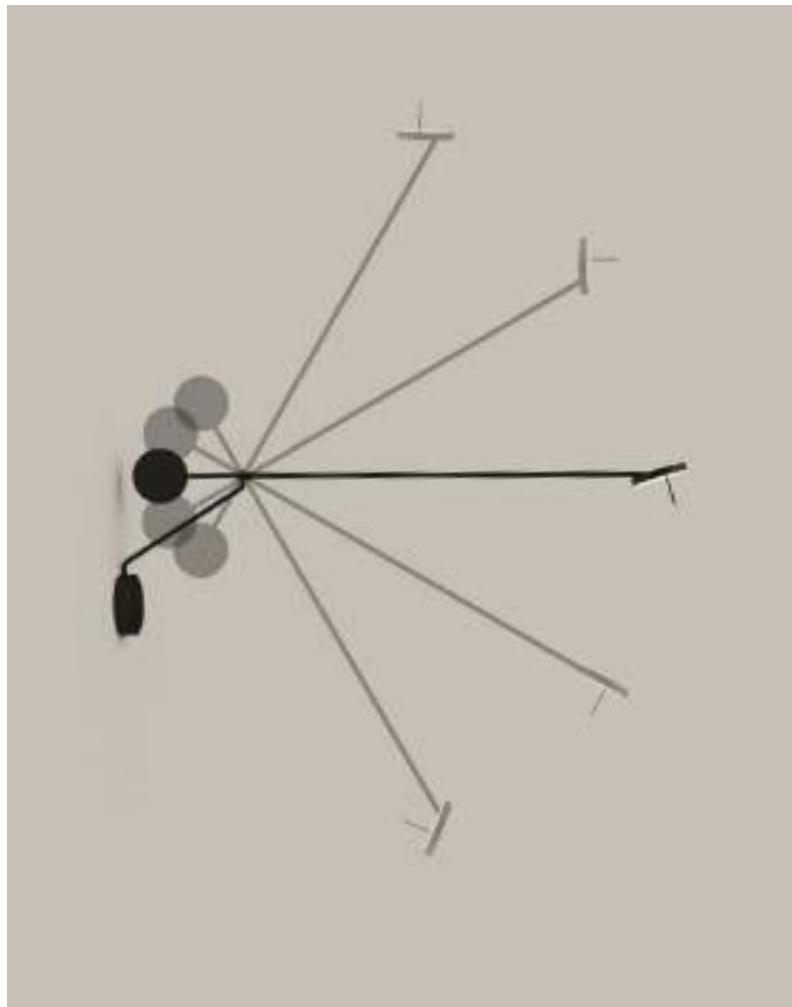

Movimiento en equilibrio

Francesc Vilaró se ha inspirado en los móviles del escultor Alexander Calder para diseñar la colección, buscando el equilibrio entre las líneas que forman la estructura y su contrapeso. En esta composición de balances, la luz puede dirigirse a cualquier punto, proyectando una luz de acento de forma muy honesta, con una gran libertad de movimientos.

Movimento em equilíbrio

Francesc Vilaró inspirou-se nos móveis do escultor Alexander Calder para criar a coleção, procurando um equilíbrio entre as linhas que formam a estrutura e o seu contrapeso. Nesta composição de equilíbrios, a luz pode ser dirigida para qualquer ponto, projetando uma luz de realce de uma forma muito honesta, com uma grande liberdade de movimentos.



La rotación del cabezal
permite dirigir la luz.
A rotação da cabeça
permite dirigir a luz.



Invisible Wall Fixture

QS

| | | | | | |
|-------------------|-----------------|--|----------|--|---------|
| BODY MAT ST,AL | DIF MAT PMMA | | 350° | | DIM |
|-------------------|-----------------|--|----------|--|---------|

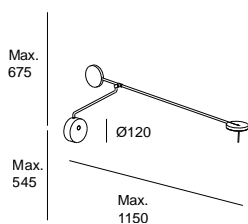

LED | CRI 92 | W Total 10.5

Negro Preto 05

| | K | Real Lm | Structure | Code |
|---------------------------|--------------|------------|-----------|--|
| TOUCH DIMMING 100-240V | 2700 3000 | 534 550 | 05 05 | 05-7385-05-05 05-5693-05-05 |

QS Quick Service | 2-6 días laborables (tiempo de transporte no incluido)
Quick Service | 2-6 dias úteis (tempo de transporte não incluído)

Prolix



Performance Universe



P. 154



P. 350



Geometría lumínica

Prolix es un juego de geometrías estructurales y lumínicas que no deja nada al azar. Es una pieza que presume de una piel decorativa, con una silueta facetada y una elegancia innata. Este aplique de óptica bidireccional baña las paredes con luz superior e inferior para crear un efecto de luz armónico tanto en pasillos, como en zonas públicas donde se precisa de una luz ambiental confortable y cálida.

Geometria lumínica

Prolix é um jogo de geometrias estruturais e lumínicas que não deixa nada ao acaso. É uma peça que ostenta uma pele decorativa, com uma silhueta facetada e uma elegância inata. Este aplique de ótica bidireccional banha as paredes com luz superior e inferior para criar um efeito de iluminação harmonioso tanto em corredores como em áreas públicas onde é necessária uma luz ambiente confortável e quente.



Prolix

QS

| |
|----------|
| BODY MAT |
| AL |

| |
|---------|
| DIF MAT |
| PMMA |

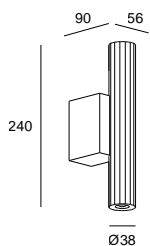

LED | K 2700 | CRI 92 | W Total 18.8 | Real Lm 358

Negro Preto 05 ●
Oro mate Ouro mate DN ●



PHASE CUT 220-240VAC

Structure

Code

05 ●
DN ●

05-8513-05-05
05-8513-DN-DN

Linea



Essential Universe



El clásico up&down cilíndrico llevado a su mínima expresión

Disponible en doble emisión y simple emisión, Linea ha nacido para ser un referente en el mercado en cuanto a apliques cilíndricos para áreas residenciales y hoteles que requieren funcionalidad y estética con un coste asequible. Su diseño ultra compacto, limpio y minimalista, así como su temperatura de color cálida 2700K, lo hacen adecuado para iluminar espacios tanto exteriores como interiores. Está disponible en acabados gris antracita y blanco.

O clássico up&down cilíndrico levado à sua mínima expressão

Disponível em emissão dupla e emissão simples, Imo foi criado para ser uma referência no mercado em termos de apliques cilíndricos para áreas residenciais e hotéis que exigem funcionalidade e estética a um custo acessível. O seu design ultracompacto, limpo e minimalista e a temperatura de cor quente de 2700K tornam-na adequada para iluminar espaços interiores e exteriores. Está disponível nos acabamentos cinzento antracite e branco.

Linea Single Emisión

NEW

QS

| |
|----------|
| BODY MAT |
| AL |

| |
|---------|
| DIF MAT |
| PC |



| |
|---------|
| 50000h |
| L80 B20 |

| |
|---------|
| 2 |
| MacAdam |

| |
|----|
| IP |
| 54 |

| |
|----|
| IK |
| 04 |

| |
|---------|
| LOW |
| FLICKER |

| |
|----------|
| SEA SIDE |
| SUITABLE |



Gris urbano Cinzento urbano Z5 ●
Blanco Branco 14 ○

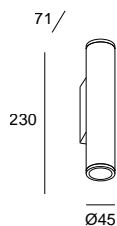

LED

| K | CRI | W Total | Real Lm | Optics | Code | |
|------|-----|---------|---------|--------|----------|-----------------------------------|
| 2700 | 80 | 2.8 | 237 | 18° | 05-E209- | Z5 ● 14 ○ - CK ON-OFF 220-240V |

Linea Double Emisión

NEW

QS

| |
|----------|
| BODY MAT |
| AL |

| |
|---------|
| DIF MAT |
| PC |



| |
|---------|
| 50000h |
| L80 B20 |

| |
|---------|
| 2 |
| MacAdam |

| |
|----|
| IP |
| 54 |

| |
|----|
| IK |
| 04 |

| |
|---------|
| LOW |
| FLICKER |

| |
|----------|
| SEA SIDE |
| SUITABLE |



Gris urbano Cinzento urbano Z5 ●
Blanco Branco 14 ○

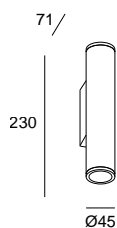

LED

| K | CRI | W Total | Real Lm | Optics | Code | |
|------|-----|---------|---------|-----------|----------|-----------------------------------|
| 2700 | 80 | 5.4 | 488 | 18° + 18° | 05-E210- | Z5 ● 14 ○ - CK ON-OFF 220-240V |



Veneto



Performance Universe



P. 120



Difusor de metacrilato.
Difusor de metacrilato.

Superficie de pared | Superfície de parede

Veneto

QS

BODY MAT

DIF MAT

ST,AL

PMMA



Decorative Collection

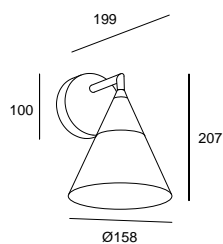

LED | K 2700 | CRI 80 | W Total 8.3 | Real Lm 452

Latón pulido Latão polido DO



ON-OFF 100-277V

Structure

Code

DO

05-7588-DO-DO

Big Bang



Performance Universe



Protagonismo de día y de noche

La forma circular de los componentes de Big Bang y sus acabados blanco texturizado y dorado en el centro, consiguen que la pieza transmita sensaciones tanto apagada como encendida. Apagada decora la estancia con la armonía de sus formas y cuando se enciende genera una luz indirecta con un halo lumínico muy especial que no pasa desapercibido.

Protagonismo de dia e de noite

A forma circular dos componentes do Big Bang e os seus acabamentos branco texturizado e dourado no centro fazem com que a peça transmita sensações tanto desligada como quando acesa. Desligada, decora a divisão com a harmonia das suas formas e quando se acende gera uma luz indireta com um feixe lumínico muito especial que não passa despercebido.



Big Bang

QS

| | | |
|----------|---------|--|
| BODY MAT | DIF MAT | |
| AL | PMMA | |

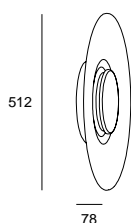

LED | K 3000 | CRI 92 | W Total 25 | Real Lm 760

Blanco Branco BW



ON-OFF 100-240V

Structure

Code

BW

05-5085-BW-BW

Attic



Performance Universe



P. 129



Riqueza compositiva

Attic es un sistema de iluminación extremadamente funcional gracias a la gran facilidad de instalación y adición de luminarias. La luz de sus bombillas puede plantearse tanto para zonas de trabajo como para crear ambientes relajados. Además, el efecto lumínico que generan las aperturas laterales de la pantalla proporciona una integración total de la estructura del cableado en la composición final de la pieza. Con posibilidad de personalización del color de las pantallas y tres formas geométricas combinables entre ellas, Attic es una pieza modular en todos los sentidos.

Riqueza compositiva

O Attic é um sistema de iluminação extremamente funcional graças à grande facilidade de instalação e de adição de luminárias. A luz das suas lâmpadas pode ser utilizada tanto para zonas de trabalho como para criar ambientes descontraídos. Além disso, o efeito lumínico gerado pelas aberturas laterais do abajur permite uma integração total da estrutura de cablagem na composição final da peça. Com a possibilidade de personalizar a cor dos abajures e três formas geométricas combináveis entre si, Attic é uma peça modular em todos os sentidos.



Configura tu Attic

Configure a sua Attic



Configurator for customisation available.
 Configurateur de personnalisation disponible.
attic.ledsc4.com

1 Instalación

Installation

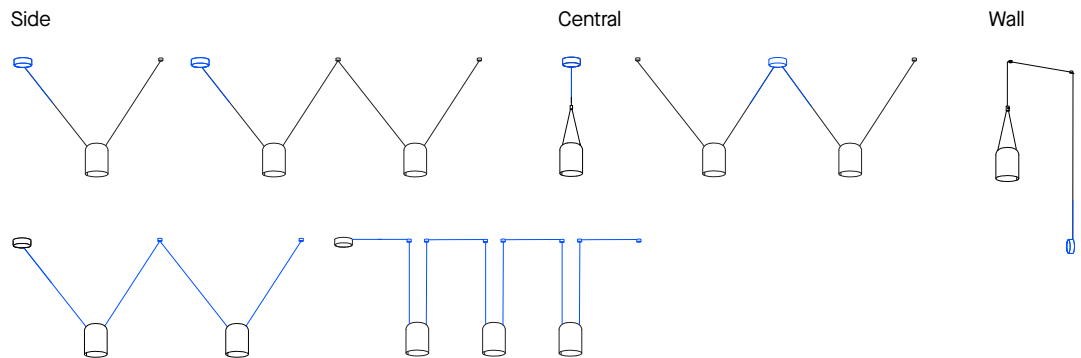

Con 2 opciones de instalación
 Con 2 opções de instalação

No hay opciones de instalación para el modelo individual con florón central.
 Não disponível para o modelo individual com roseta central.

2 Longitud de cable

Comprimento do cabo

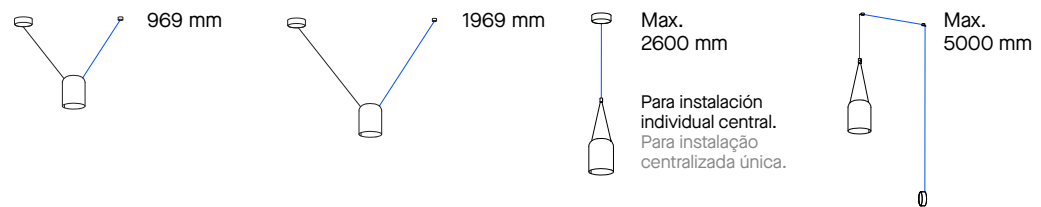

3 Pantalla

Quebra-luz



4 Combinaciones estandar

Combinações standard

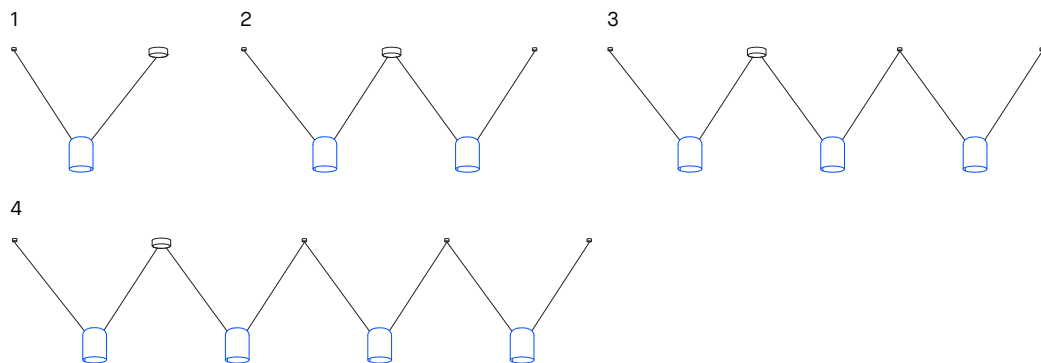

Más opciones a través del configurador.
 Mais opções através do configurador.

4 Acabados

Acabamentos



Múltiples colores personalizables bajo petición.
 Várias cores personalizáveis a pedido.



Attic Rectangular Shape

QS

| | |
|----------|--|
| BODY MAT | |
| AL | |

Blanco Branco 14

Negro Preto 05

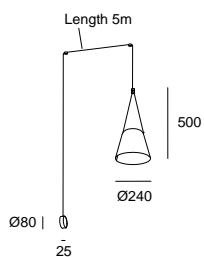

E27 | W Max. 15

| Structure | Exterior Screen | Code |
|-----------|-----------------|--|
| 05 05 | 05 14 | 05-7388-05-05 05-7388-05-14 |
| 05 05 | 05 14 | 05-7389-05-05 05-7389-05-14 |
| 05 05 | 05 14 | 05-9007-05-05 05-9007-05-14 |

*Bombilla no incluida.
 *Lâmpada não incluída.

Super Attic



Performance Universe



P. 136



Presencia y personalidad

Super Attic se adueña sin complejos del protagonismo del ambiente. Su pantalla cónica de grandes dimensiones emite un haz de luz con una destacada presencia, aportando personalidad al espacio.

Presença e personalidade

Super Attic assume sem complexos o protagonismo do ambiente. O seu quebra-luz cónico de grandes dimensões emite um feixe de luz com uma presença de destaque, dando personalidade ao espaço.

Configura tu Attic Configure a sua Attic



Configurator for customisation available.
Configurateur de personnalisation disponible.
attic.ledsc4.com

1 Instalación Installation

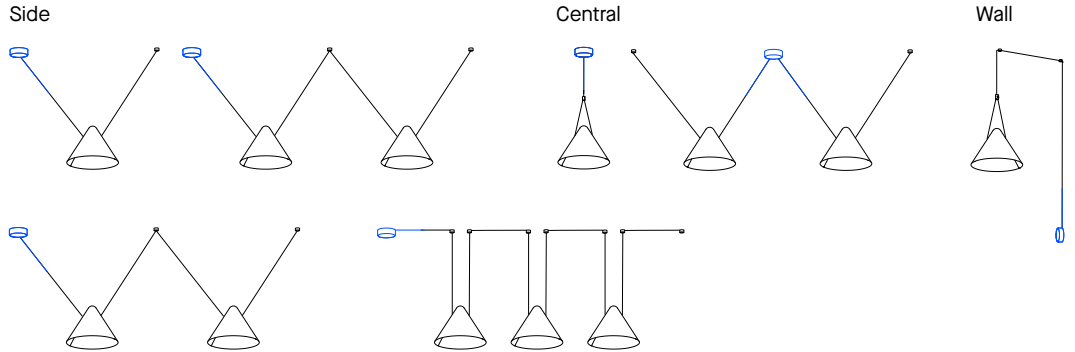

Con 2 opciones de instalación
Con 2 opções de instalação

No hay opciones de instalación para el modelo individual con florón central.
Não disponível para o modelo individual com roseta central.

2 Longitud de cable Comprimento do cabo

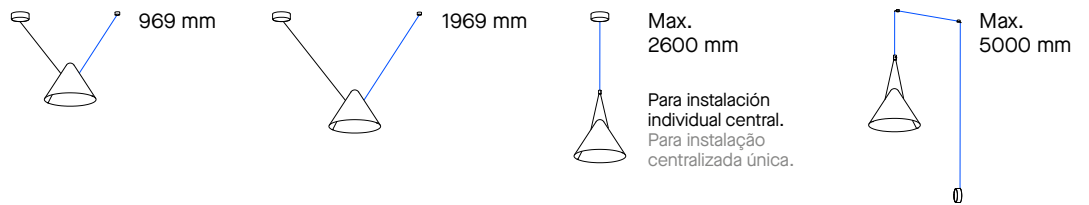

3 Combinaciones estandar Combinações standard

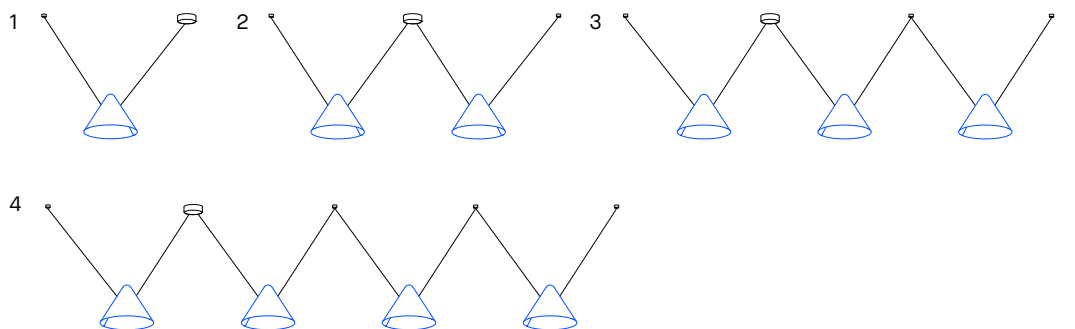

Más opciones a través del configurador.
Mais opções através do configurador.

4 Acabados Acabamentos

05 Black



Múltiples colores personalizables bajo petición.
Várias cores personalizáveis a pedido.

Super Attic

QS

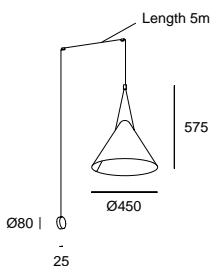
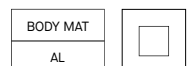

E27 | W Max. 15

Negro Preto 05 ●

Structure Exterior Screen

Code

05 ● 05 ●

05-8348-05-05

*Bombilla no incluida.
*Lâmpada não incluída.

H



Performance Universe



P. 140



P. 216



P. 258



Distinción natural

De líneas simples y puras, el diseño H de Benedito aporta una elegancia natural al espacio que habita. Con opción de instalación empotrada o en superficie, H destaca en el ambiente por la calidez de su luz y por el juego de sombras que produce la delicada apertura superior en la pieza.

Distinção natural

De linhas simples e puras, o design H de Benedito traz uma elegância natural ao espaço. Com opção de instalação encastrada ou na superfície, H destaca-se no ambiente pela calidez da sua luz e pelo jogo de sombras que a delicada abertura superior na peça produz.



Dos opciones de empotrado.
 Duas opções de encastrado.

Opción de aplique colgante con cordón embelezador (instalación eléctrica por pared).
 Opção de aplique suspenso com cordão embelezador (instalação elétrica por parede).

H

QS

| | | |
|----------|---------|--|
| BODY MAT | DIF MAT | |
| ST | ACR | |

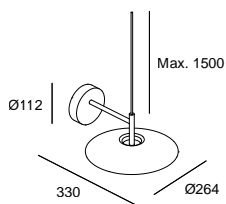

LED | K 2700 | CRI 92 | W Total 17 | Real Lm 627

Negro Preto 05 ●
 Oro mate Ouro mate DN ●



Structure

Code

ON-OFF 100-277V

05 ●
 DN ●

05-7742-05-05
 05-7742-DN-DN

Organic



Performance Universe



P. 229

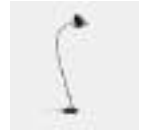

P. 253



Suave y armónica

El perfil de esta pieza, suave y armónica, se inspira en las formas orgánicas de las flores y las hojas. Su pantalla ligeramente curvada, con un interior dorado, se integra en el espacio de forma sutil y natural.

Suave e harmonioso

O perfil desta peça, suave e harmónica, é inspirado nas formas orgánicas das flores e folhas. O seu quebra-luz ligeiramente curvo, com um interior dourado, integra-se no espaço de forma subtil e natural.

Organic

QS

| | | | |
|----------|--|------|-----|
| BODY MAT | | | |
| ST | | 355° | 90° |

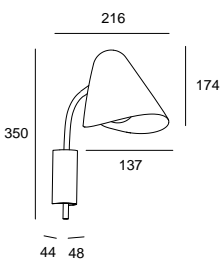

E14 | W Max. 9

Negro Preto 05 ●

Structure

Code

05 ●

05-7582-05-05

Acc. comunes no incluidos
Ac. comuns não incluídos

Cable de conexión
Cabo de ligação

71-7660-00-00

MISO



Essential Universe



P. 346



De líneas suaves y discretas, Miso es un plafón esencial que se adapta a todos los espacios. Con dos medidas disponibles, ofrece una enorme flexibilidad de acabados gracias a la combinación de colores de su estructura interior y exterior.

Com linhas suaves e discretas, Miso é um plafon essencial que se adapta a todos os espaços. Com duas medidas disponíveis, oferece uma enorme flexibilidade de acabamentos graças à combinação de cores da sua estrutura interior e exterior.

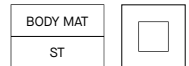

Miso 285mm

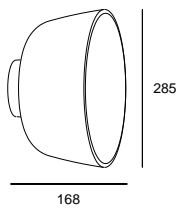

E27 | W Max. 15

| Exterior Screen | Interior Screen | Code |
|-----------------|-----------------|-------------------------|
| 05 ● | 14 ○ | 15-8330-05-14 |
| 05 ● | DL ● | 15-8330-05-DL QS |
| 14 ○ | 14 ○ | 15-8330-14-14 QS |
| 14 ○ | DL ● | 15-8330-14-DL |

Blanco Branco 14 ○
 Negro Preto 05 ●
 Oro Ouro DL ●

*Bombilla no incluída.
 *Lâmpada não incluída.

Miso 433mm

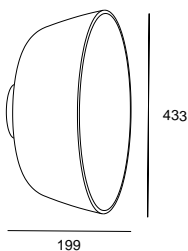

E27 | W Max. 15

| Exterior Screen | Interior Screen | Code |
|-----------------|-----------------|-------------------------|
| 05 ● | DL ● | 15-8331-05-DL QS |
| 14 ○ | 14 ○ | 15-8331-14-14 QS |
| 14 ○ | DL ● | 15-8331-14-DL QS |

Blanco Branco 14 ○
 Negro Preto 05 ●
 Oro Ouro DL ●
 Gris piedra Cinzento pedra EM ●

*Bombilla no incluída.
 *Lâmpada não incluída.

Drone



Performance Universe



Este aplique de medidas reducidas presenta múltiples opciones de acabados combinados en su versión doble o simple.

Este aplique de medidas reducidas apresenta múltiplas opções de acabamentos combinados na sua versão dupla ou simples.



Drone Single

QS

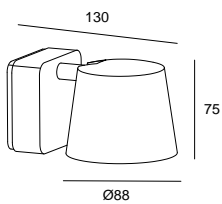

LED | K 2700 | CRI 80 | W Total 8.6 | Real Lm 350



ON-OFF 100-277V

Structure Interior Screen Code

| | | | | |
|----|---|----|---|----------------------|
| 14 | ○ | 06 | ● | 05-5306-14-06 |
| 14 | ○ | 21 | ◐ | 05-5306-14-21 |
| 14 | ○ | F5 | ● | 05-5306-14-F5 |
| CI | ● | 06 | ● | 05-5306-CI-06 |
| CI | ● | 21 | ◐ | 05-5306-CI-21 |
| CI | ● | F5 | ● | 05-5306-CI-F5 |

BODY MAT
AL

DIF MAT
AL



355°

0° a 90°

Blanco Branco 14 ○
Cromo Cromado 21 ◐

Oro Ouro F5 ●
Marrón Castanho CI ●
Cobre Cobre 06 ●

Drone Double

QS

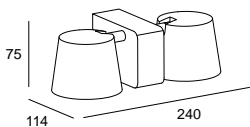

LED | K 2700 | CRI 80 | W Total 16.3 | Real Lm 613



ON-OFF 100-277V

Structure Interior Screen Code

| | | | | |
|----|---|----|---|----------------------|
| 14 | ○ | 06 | ● | 05-5307-14-06 |
| 14 | ○ | 21 | ◐ | 05-5307-14-21 |
| 14 | ○ | F5 | ● | 05-5307-14-F5 |
| CI | ● | 06 | ● | 05-5307-CI-06 |
| CI | ● | 21 | ◐ | 05-5307-CI-21 |
| CI | ● | F5 | ● | 05-5307-CI-F5 |

BODY MAT
AL

DIF MAT
AL



355°

0° a 90°

Blanco Branco 14 ○
Cromo Cromado 21 ◐

Oro Ouro F5 ●
Marrón Castanho CI ●
Cobre Cobre 06 ●

Vetro



Performance Universe



P. 349



P. 370



Un clásico con un vidrio prensado de doble grosor especial.

Um clássico com um vidro prensado de dupla espessura especial.



Vetro

QS

| | | | |
|----------|---------|--|----|
| BODY MAT | DIF MAT | | IP |
| ST | GLA | | 44 |

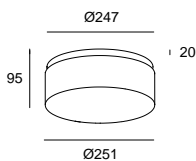

LED | K 3000 | CRI 80 | W Total 22.4 | Real Lm 1240

Blanco Branco 14
Cristal pintado blanco interior G5
Vidro pintado branco interior

| | Body | Difussor | Code |
|-----------------|--------------------------|-------------------------------------|---------------|
| ON-OFF 220-240V | 14 <input type="radio"/> | G5 <input checked="" type="radio"/> | 05-7387-14-G5 |

Nude



Essential Universe



P. 231



P. 265



Instalación empotrada.
instalação encastrada.

Instalación en superficie.
Instalação de superfície.

Nude

QS

| | | |
|----------|--|------|
| BODY MAT | | |
| AL | | 360° |

Negro Preto 05 ●
Oro mate Ouro mate DN ●

E27 | W Max. 15

Structure

Head

Code

05 ● 05 ●
05 ● DN ●

05-8515-05-05
05-8515-05-DN

*Bombilla no incluida.
*Lâmpada não incluida.

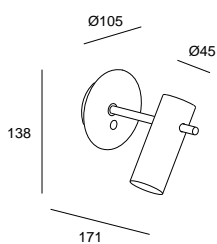

80 3-30 mm

QS Quick Service | 2-6 días laborables (tempo de transporte no incluido)
Quick Service | 2-6 dias úteis (tempo de transporte não incluido)

Metrica



Essential Universe



P. 204



P. 236



P. 270



Metrica Shade

QS

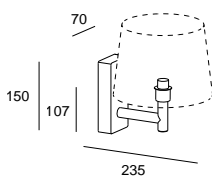
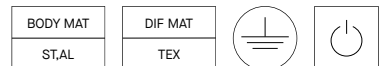

E27 | W Total Max. 15

Negro Preto 05 ●
Níquel satinado Níquel acetinado 81 ●

Structure

05 ●
81 ●

Code

05-8399-05-82
05-8399-81-82

*Bombilla no incluida.
*Lâmpada não incluida.

No incluidos y requeridos

Não incluido e requeridos



14 ○
05 ●
BY ●

PAN-157-14
PAN-157-05
PAN-157-BY

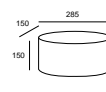

14 ○
BY ●

PAN-177-14
PAN-177-BY

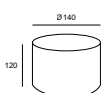

14 ○
BY ●

PAN-175-14
PAN-175-BY

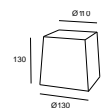

14 ○
BY ●

PAN-178-14
PAN-178-BY

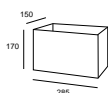

14 ○
BY ●

PAN-176-14
PAN-176-BY

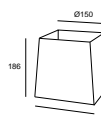

14 ○
BY ●

PAN-179-14
PAN-179-BY

QS Quick Service | 2-6 días laborables (tiempo de transporte no incluido)
Quick Service | 2-6 dias úteis (tempo de transporte não incluido)

Fino



Performance Universe



Perfecta integración arquitectónica

Elegancia, tecnicidad y sofisticación con un diseño que se estructura en líneas rectas y ángulos perfectos.

Perfeita integração arquitetónica

Elegância, tecnicidade e sofisticação com um design que se estrutura em linhas retas e ângulos perfeitos.



Doble emisión de luz.
Dupla emissão de luz.

Fino 540mm

| | |
|----------|---------|
| BODY MAT | DIF MAT |
| AL | PMMA |

Blanco Branco 14
Negro Preto 60

LED | K 2700 | CRI 80 | W Total 13.2 | Real Lm 452

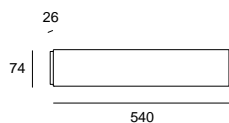

Structure

Code

ON-OFF 100-240V

14
60

05-7573-14-14
05-7573-60-60

1-10V 220-240V

14
60

05-7574-14-14
05-7574-60-60

Fino 1040mm

| | | |
|----------|---------|--|
| BODY MAT | DIF MAT | |
| AL | PMMA | |

Blanco Branco 14
Negro Preto 60

LED | K 2700 | CRI 80 | W Total 24.6 | Real Lm 905

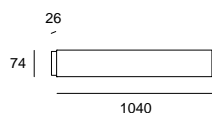

Structure

Code

ON-OFF 220-240V

14
60

05-7575-14-14
05-7575-60-60

1-10V 220-240V

14
60

05-7576-14-14
05-7576-60-60

Duna



Performance Universe



Cálida y atemporal

Duna se adapta al espacio de forma discreta y elegante y se configura como una opción ideal para ofrecer una luz bidireccional funcional para cualquier escena.

Acolhedor e intemporal

Duna adapta-se ao espaço de forma discreta e elegante e configura-se como uma opção ideal para oferecer uma luz bidireccional funcional para qualquer cenário.

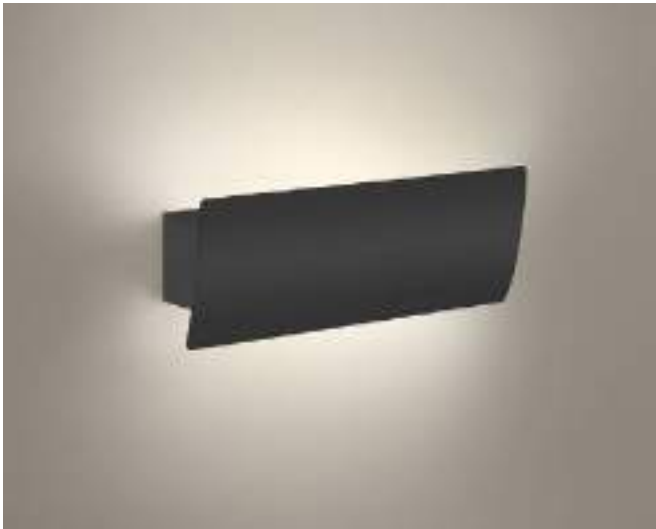

Duna

QS

| | | |
|----------|---------|--|
| BODY MAT | DIF MAT | |
| AL | PMMA | |

- Blanco Branco 14
- Negro Preto 60
- Blanco opal Branco opalino M1

LED | K 2700-3000-4000 | CRI 80 | W Total 27 | Real Lm 1841

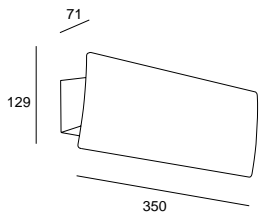

| | Structure | Difussor | Code |
|--------------------|---|--|--|
| PHASE CUT 220-240V | 14 <input type="radio"/> 60 <input checked="" type="radio"/> | M1 <input type="radio"/> M1 <input type="radio"/> | 05-A091-14-M1 05-A091-60-M1 |

Lia



Essential Universe



Lia

QS

| | | | |
|----------|---------|--|----|
| BODY MAT | DIF MAT | | IP |
| AL | GLA | | 44 |

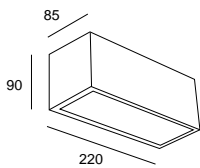

E27 | W Max. 15

Blanco Branco 14

Cristal satinado Vidro acetinado B8

Structure **Difussor**

Code

14 B8

05-4401-14-B8

*Bombilla no incluida.
*Lâmpada não incluída.

Lia LED



Performance Universe



Aplique esencial en dos tamaños con doble emisión.

Aplique essencial em dois tamanhos com emissão dupla.





Lia LED 250mm

NEW

QS

| | | |
|----------|---------|--|
| BODY MAT | DIF MAT | |
| ST | PC | |

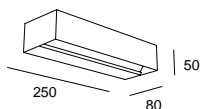

LED | K SW 2700-3000-4000K | CRI 92 | W Total 8.1 | Real Lm 475

Blanco Branco 14
 Níquel satinado Níquel acetinado 81



Structure Code

ON-OFF 100-240V

14
 81

05-A103-14-14
 05-A103-81-81

Lia LED 400mm

NEW

QS

| | | |
|----------|---------|--|
| BODY MAT | DIF MAT | |
| ST | PC | |

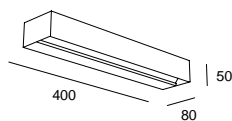

LED | K SW 2700-3000-4000K | CRI 92 | W Total 18.7 | Real Lm 1187

Blanco Branco 14
 Níquel satinado Níquel acetinado 81



Structure Code

ON-OFF 220-240V

14
 81

05-A104-14-14
 05-A104-81-81

Lia LED 600mm

NEW

QS

| | | |
|----------|---------|--|
| BODY MAT | DIF MAT | |
| ST | PC | |

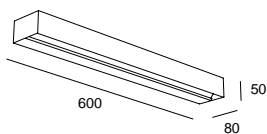

LED | K SW 2700-3000-4000K | CRI 92 | W Total 28.2 | Real Lm 1864

Blanco Branco 14
 Níquel satinado Níquel acetinado 81



Structure Code

ON-OFF 200-240V

14
 81

05-A105-14-14
 05-A105-81-81

Mini

Iluminación Up&Down | Iluminação Up&Down



Essential Universe



Perfecta para fachadas de reducidas dimensiones

La colección de apliques up&down Mini, como su nombre indica, es extremadamente compacta y está concebida para iluminar con estilo y calidez espacios reducidos como pequeñas terrazas, balcones y fachadas. Su valor principal es la versatilidad, ya que permite iluminar espacios tanto exteriores como interiores gracias al diseño atemporal y a la luz suave con temperatura de color 2700K. Está disponible en LED intergado y en portalámparas G9.

Perfeita para pequenas fachadas

A coleção de apliques up&down Mini, como o seu nome indica, é extremamente compacta e foi concebida para iluminar com estilo e calidez espaços reduzidos, como pequenos terraços, varandas e fachadas. O seu principal valor é a versatilidade, uma vez que permite iluminar tanto espaços exteriores como interiores graças ao seu design intemporal e à luz suave com uma temperatura de cor de 2700K. Está disponível em LED interligado e em suporte de lâmpadas G9.



| | | | | |
|----------|---------|--|---------|---------|
| BODY MAT | DIF MAT | | 50000h | 3 |
| AL | PC | | L80 B20 | MacAdam |

Mini Cube

NEW

QS

| | | |
|----|----|----------|
| IP | IK | SEA SIDE |
| 54 | 09 | SUITABLE |

Gris urbano Cinzento urbano Z5 ●
Blanco Branco 14 ○

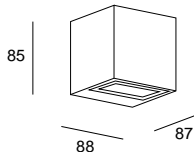
**LED**

| K | CRI | W Total | Real Lm | Code | |
|------|-----|---------|---------|-----------------------------------|-----------------|
| 2700 | 80 | 5.5 | 623 | 05-E202- Z5 ● 14 ○ - CK | ON-OFF 220-240V |

Mini Vertical

NEW

QS

| | | | |
|----|----|---------|----------|
| IP | IK | LOW | SEA SIDE |
| 54 | 10 | FLICKER | SUITABLE |

Gris urbano Cinzento urbano Z5 ●
Blanco Branco 14 ○

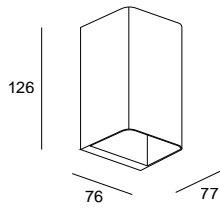
**GU9**

| W | Code |
|--------|-----------------------------------|
| Max. 6 | 05-E203- Z5 ● 14 ○ - M1 |

*Bombilla no incluída.
*Lâmpada não incluída.

Mini Horizontal

NEW

QS

| | | | | |
|----|----|---------|----------|--|
| IP | IK | LOW | SEA SIDE | |
| 54 | 10 | FLICKER | SUITABLE | |

Gris urbano Cinzento urbano Z5 ●
Blanco Branco 14 ○

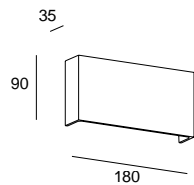
**LED**

| K | CRI | W Total | Real Lm | Code | |
|------|-----|---------|---------|-----------------------------------|-----------------|
| 2700 | 80 | 10.4 | 717 | 05-E207- Z5 ● 14 ○ - CK | ON-OFF 220-240V |

Cut NEW



Essential Universe



Perfecta para fachadas de reducidas dimensiones

Cut es el aplique perfecto cuando se busca algo más que un aplique up&down convencional. Su distintivo corte minimalista provoca un plus de personalidad y elegancia en las fachadas. Además, su diseño limpio, la tornillería oculta, la temperatura de color cálida y la disponibilidad en acabados gris antracita y blanco lo hace ideal para iluminar espacios tanto exteriores como interiores.

Perfeito para fachadas pequenas

Cut é o aplique perfeito quando se procura algo mais do que um aplique up&down convencional. O seu corte minimalista distinto confere personalidade e elegância às fachadas. Além disso, o seu design limpo, as ferragens ocultas, a temperatura de cor quente e a disponibilidade nos acabamentos cinzento antracite e branco tornam-no ideal para iluminar espaços interiores e exteriores.

Superficie de pared | Superfície de parede

Decorative Collection

322

Cut
NEW
QS

| | | | | | | | | | |
|----------------|----------------|--|-------------------|--------------|----------|----------|----------------------|--|--|
| BODY MAT AL | DIF MAT GLA | | 50000h L80 B20 | 3 MacAdam | IP 54 | IK 04 | SEA SIDE SUITABLE | | |
|----------------|----------------|--|-------------------|--------------|----------|----------|----------------------|--|--|

Gris urbano Cinzento urbano Z5
Blanco Branco 14

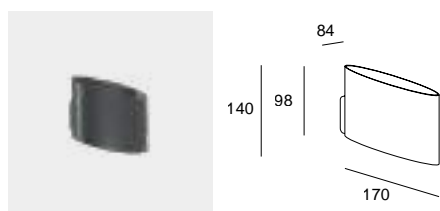

| LED | | | | | |
|------|-----|---------|---------|--|-----------------|
| K | CRI | W Total | Real Lm | Code | |
| 2700 | 80 | 9.8 | 688 | 05-E206- <input checked="" type="radio"/> Z5 <input type="radio"/> 14 - CK | ON-OFF 220-240V |

QS Quick Service | 2-6 días laborables (tiempo de transporte no incluido)
Quick Service | 2-6 dias úteis (tempo de transporte não incluído)



Wilson

Performance Universe



Un plus de elegancia en todo tipo de paredes

El limpio diseño de Wilson, ligeramente redondeado y con la tornillería oculta; junto con su haz de luz definido y un sugerente juego de luces y sombras, hacen que esta colección sea muy valorada en proyectos que necesitan un plus de elegancia.

Um plus de elegância em todo o tipo de paredes

O design limpo da Wilson, ligeiramente arredondado e com os parafusos ocultos, juntamente com o seu feixe de luz definido e um sugestivo jogo de luzes e sombras, tornam esta coleção altamente valorizada nos projetos que necessitam de um toque extra de elegância.

Cuenta con la posibilidad de cambiar el ángulo de salida de luz según las necesidades del espacio de forma rápida y sencilla (05-9683).

Tem a possibilidade de alterar o ângulo de saída da luz de acordo com as necessidades do espaço de forma rápida e simples (05-9683).

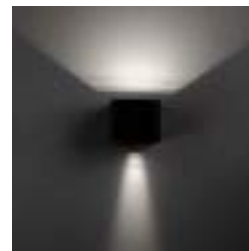

Wilson Square

QS

| | | | | | | | | | |
|----------|---------|--|---------|---------|----|----|----------|-----|--------|
| BODY MAT | DIF MAT | | 50000h | 3 | IP | IK | SEA SIDE | LED | DRIVER |
| AL | GLA | | L80 B20 | MacAdam | 65 | 08 | SUITABLE | | |

Gris urbano Cinzento urbano Z5 ●
Blanco Branco 14 ○

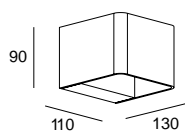

LED

| K | CRI | W Total | Real Lm | Code | |
|------|-----|---------|---------|-----------------------------|-----------------|
| 2700 | 80 | 10.2 | 602 | 05-9683 - Z5 ● 14 ○ - CK | ON-OFF 100-240V |
| 3000 | 80 | 10.2 | 623 | 05-9683 - Z5 ● 14 ○ - CL | ON-OFF 100-240V |

○ 34 ● J6 ● 60

* Acabados The Colours. Consultar precios en tarifa y plazos de entrega con equipo comercial.
* Acabamentos The Colours. Consultar preços e prazos de entrega com a nossa equipa comercial.

Ges



Essential Universe



Ges Rectangular 220mm

QS

BODY MAT
PLSTER

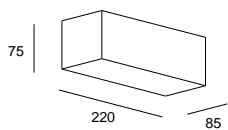

E14 | W Max. 9

Blanco Branco 14 ○

Structure

Code

14 ○

05-1793-14-14

Ges Square

QS

BODY MAT
PLSTER

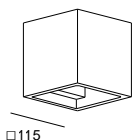

G9 | W Max. 6

Blanco Branco 14 ○

Structure

Code

14 ○

05-1794-14-14

Ges Circular



Essential Universe



La perfección del círculo

Ges representa la perfección del círculo en la mínima expresión. El halo de luz circular le confiere un efecto volátil y cálido a la vez.

A perfeição do círculo

Ges representa a perfeição do círculo na expressão mínima. O feixe de luz circular dá-lhe um efeito volátil e acolhedor ao mesmo tempo.

Ges Round Ø260mm

QS

| | | |
|-----------|---------|--|
| BODY MAT | DIF MAT | |
| ST,PLSTER | ACR | |

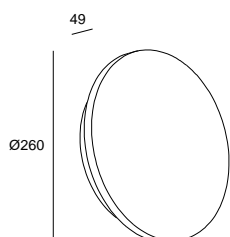

LED | K 2700-3000-4000 | CRI 90 | W Total 8.7 | Real Lm 535

Blanco Branco 14



ON-OFF 100-240V

Structure

Code

14

05-A088-14-14

Superficie de techo

Superfície de teto



Gong

332



Levels

328



Spark

340



Vetro

349



Miso

346



Bol

348



Caprice

344



Prolix

350



Simply

353



Pipe

354



Stylus

355

Levels



Performance Universe



P. 086



P. 212



P. 250



Una luz con gran carisma

La versión plafón de Levels es una estructura viva que crece y decrece en un juego orgánico de estructuras, niveles y densidades. Con tres acabados diferentes que se combinan con distintas opacidades de vidrio, la colección hace gala de un carisma innato que se adapta con facilidad a todos los espacios, tanto apagada como encendida.

Uma luz com grande carisma

A versão plafon da Levels é uma estrutura viva que cresce e decrece num jogo orgânico de estruturas, níveis e densidades. Com três acabamentos diferentes que se combinam com diferentes opacidades de vidro, a coleção apresenta um carisma inato que se adapta com facilidade a todos os espaços, tanto ligada como desligada.



Vidrios con transparencias del 30% en el difusor pequeño, del 50% en el mediano y del 70% en el grande.

Vidros com transparências de 30% no difusor pequeno, de 50% no médio e de 70% no grande.



Levels 1 Body Ø220mm

QS

| |
|----------|
| BODY MAT |
| ST |

| |
|---------|
| DIF MAT |
| GLA |



| |
|----------------|
| SWITCH CCT |
| 2700-3000-4000 |

- Negro Preto 05 ●
- Verde Verde 08 ●
- Fumé Fumado 12 ●
- Âmbar Âmbar 15 ●

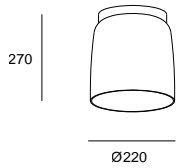

LED | K 2700-3000-4000 | CRI 92 | W Total 28 | Real Lm 2035 (3000K)

| | Structure | Difussor | Code |
|--------------------|-----------|----------|----------------------|
| PHASE CUT 220-240V | 05 ● | 08 ● | 15-A131-05-08 |
| | 05 ● | 12 ● | 15-A131-05-12 |
| | 05 ● | 15 ● | 15-A131-05-15 |
| DALI-2 110-277V | 05 ● | 08 ● | 15-A137-05-08 |
| | 05 ● | 12 ● | 15-A137-05-12 |
| | 05 ● | 15 ● | 15-A137-05-15 |

Levels 1 Body Ø320mm

QS

| |
|----------|
| BODY MAT |
| ST |

| |
|---------|
| DIF MAT |
| GLA |



| |
|----------------|
| SWITCH CCT |
| 2700-3000-4000 |

- Negro Preto 05 ●
- Verde Verde 08 ●
- Fumé Fumado 12 ●
- Âmbar Âmbar 15 ●

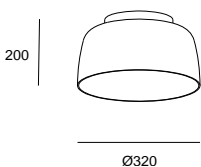

LED | K 2700-3000-4000 | CRI 92 | W Total 28 | Real Lm 2035 (3000K)

| | Structure | Difussor | Code |
|--------------------|-----------|----------|----------------------|
| PHASE CUT 220-240V | 05 ● | 08 ● | 15-A132-05-08 |
| | 05 ● | 12 ● | 15-A132-05-12 |
| | 05 ● | 15 ● | 15-A132-05-15 |
| DALI-2 110-277V | 05 ● | 08 ● | 15-A138-05-08 |
| | 05 ● | 12 ● | 15-A138-05-12 |
| | 05 ● | 15 ● | 15-A138-05-15 |

Levels 1 Body Ø420mm

QS

| |
|----------|
| BODY MAT |
| ST |

| |
|---------|
| DIF MAT |
| GLA |



| |
|----------------|
| SWITCH CCT |
| 2700-3000-4000 |

- Negro Preto 05 ●
- Verde Verde 08 ●
- Fumé Fumado 12 ●
- Âmbar Âmbar 15 ●

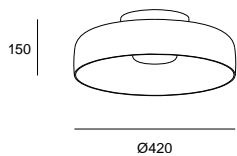





LED | K 2700-3000-4000 | CRI 92 | W Total 28 | Real Lm 2035 (3000K)

| | Structure | Difussor | Code |
|--------------------|-----------|----------|----------------------|
| PHASE CUT 220-240V | 05 ● | 08 ● | 15-A133-05-08 |
| | 05 ● | 12 ● | 15-A133-05-12 |
| | 05 ● | 15 ● | 15-A133-05-15 |
| DALI-2 110-277V | 05 ● | 08 ● | 15-A139-05-08 |
| | 05 ● | 12 ● | 15-A139-05-12 |
| | 05 ● | 15 ● | 15-A139-05-15 |

Levels 2 Bodies Ø320mm + Ø220mm







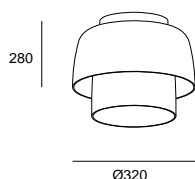





QS

| | | | |
|----------|---------|--|----------------|
| BODY MAT | DIF MAT |  | SWITCH CCT |
| ST | GLA | | 2700-3000-4000 |

| | | |
|-------------|----|---|
| Negro Preto | 05 |  |
| Verde Verde | 08 |  |
| Fumé Fumado | 12 |  |
| Ámbar Âmbar | 15 |  |



LED | K 2700-3000-4000 | CRI 92 | W Total 28 | Real Lm 2035 (3000K)

| | Structure | Difussor | Code |
|--------------------|--|---|----------------------|
| PHASE CUT 220-240V | 05  | 08  | 15-A134-05-08 |
| | 05  | 12  | 15-A134-05-12 |
| | 05  | 15  | 15-A134-05-15 |
| DALI-2 110-277V | 05  | 08  | 15-A140-05-08 |
| | 05  | 12  | 15-A140-05-12 |
| | 05  | 15  | 15-A140-05-15 |

Levels 2 Bodies Ø420mm + Ø320mm







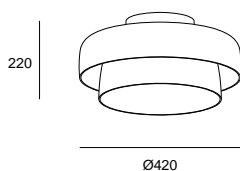





QS

| | | | |
|----------|---------|---|----------------|
| BODY MAT | DIF MAT |  | SWITCH CCT |
| ST | GLA | | 2700-3000-4000 |

| | | |
|-------------|----|---|
| Negro Preto | 05 |  |
| Verde Verde | 08 |  |
| Fumé Fumado | 12 |  |
| Ámbar Âmbar | 15 |  |



LED | K 2700-3000-4000 | CRI 92 | W Total 28 | Real Lm 2035 (3000K)

| | Structure | Difussor | Code |
|--------------------|--|---|----------------------|
| PHASE CUT 220-240V | 05  | 08  | 15-A135-05-08 |
| | 05  | 12  | 15-A135-05-12 |
| | 05  | 15  | 15-A135-05-15 |
| DALI-2 110-277V | 05  | 08  | 15-A141-05-08 |
| | 05  | 12  | 15-A141-05-12 |
| | 05  | 15  | 15-A141-05-15 |

Levels 3 Bodies Ø420mm + Ø320mm + Ø220mm







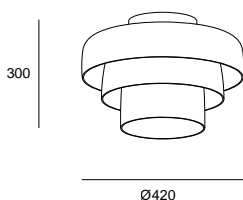





QS

| | | | |
|----------|---------|---|----------------|
| BODY MAT | DIF MAT |  | SWITCH CCT |
| ST | GLA | | 2700-3000-4000 |

| | | |
|-------------|----|---|
| Negro Preto | 05 |  |
| Verde Verde | 08 |  |
| Fumé Fumado | 12 |  |
| Ámbar Âmbar | 15 |  |



LED | K 2700-3000-4000 | CRI 92 | W Total 28 | Real Lm 2035 (3000K)

| | Structure | Difussor | Code |
|--------------------|--|---|----------------------|
| PHASE CUT 220-240V | 05  | 08  | 15-A136-05-08 |
| | 05  | 12  | 15-A136-05-12 |
| | 05  | 15  | 15-A136-05-15 |
| DALI-2 110-277V | 05  | 08  | 15-A142-05-08 |
| | 05  | 12  | 15-A142-05-12 |
| | 05  | 15  | 15-A142-05-15 |

*Los acabados y tonalidad mostrados pueden no ser completamente precisos debido a ligeras variaciones en la producción, factores de iluminación, fotográficas e impresión.

*Os acabamentos e tonalidades apresentados podem não ser totalmente precisos, devido a ligeiras variações na produção, fatores de iluminação fotográfica e de impressão.

Gong



Performance Universe



P. 104



Calidez y luz ambiental: pureza e innovación en el uso de materiales

Gong es una luminaria que sorprende, apropiándose de los espacios con una luz tamizada que se filtra de forma sugerente a través del tejido de su campana. Carisma y honestidad definen este diseño de Francesc Vilaró. Además de aportar una sensibilidad especial jugando con la vista y el tacto, el diseño de Gong está pensado para ofrecer un alto rendimiento lumínico en un cuerpo decorativo. Con tres acabados estándar y opciones personalizadas de tejido bajo pedido, Gong destaca por su carácter único, tanto si está encendida como apagada.

Calor e luz ambiente: pureza e inovação na utilização dos materiais

Gong é uma luminária que surpreende, apropriando-se dos espaços com uma luz que é filtrada de forma sugestiva através do tecido da sua campânula. Carisma e honestidade definem este design Francesc Vilaró. Além de proporcionar uma sensibilidade especial jogando com a visão e o tato, o design de Gong destinase a oferecer um alto rendimento lumínico num corpo decorativo. Com três acabamentos standard e opções de tecido personalizadas sob pedido, Gong destaca-se pelo seu caráter único, quer esteja ligada ou desligada.





El alma de Gong reside en su tejido, un material artesanal y duradero, resistente a la abrasión e ignífugo.

A alma de Gong reside no seu tecido, um material artesanal, duradouro, resistente à abrasão e ignífugo.

Gong se presenta en tres acabados inspirados en la naturaleza —arena, terracota y carbón— con marco metálico a juego para una imagen homogénea y elegante. Además, ofrece tejido personalizado bajo pedido.

Gong está disponível em três acabamentos inspirados na natureza – areia, carvão e terracota – com uma estrutura metálica a condizer para uma imagem homogénea e elegante. Oferece também tecido personalizado mediante pedido.



Beige Arena
Bege Areia



Terracota
Terracota



Negro Carbón
Preto Carvão

Posibilidad de modificar la temperatura de color mediante un switch CCT.

A temperatura da cor pode ser alterada através de um switch CCT.



2700K



3000K



4000K

Gong incorpora difusor opal y microprismático que garantiza un control lumínico y el máximo confort visual.

Gong incorpora um difusor opalino e microprismático que garante o controlo lumínico e o máximo conforto visual.



Opal
Opalino



Microprismático
Microprismático



Gong incorpora dos nuevas medidas y ofrece ahora tres tamaños —Ø340, Ø600 y Ø1000 mm— disponibles en versión colgante o plafón.

Gong incorpora duas novas medidas e oferece agora três tamanhos – Ø340, Ø600 e Ø1000 mm – disponíveis nas versões de suspensão ou plafon.

Gong Ø340 Microprisma

| |
|----------|
| BODY MAT |
| ST |

| |
|---------|
| DIF MAT |
| PMMA |



LED | CRI 92 | W Totals 18.7

181

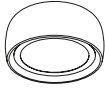

Ø342

| | K | Real Lm | Ring | Screen | Code |
|---------------------------|------|---------|------|--------|----------------------|
| PHASE CUT 220-240V | 2700 | 1263 | FB | FA | 15-A350-FB-FA |
| | | | W1 | L1 | 15-A350-W1-L1 |
| | | | 60 | EZ | 15-A350-60-EZ |
| DALI-2 / PUSH 220-240V | 2700 | 1263 | FB | FA | 15-A351-FB-FA |
| | | | W1 | L1 | 15-A351-W1-L1 |
| | | | 60 | EZ | 15-A351-60-EZ |
| PHASE CUT 220-240V | 3000 | 1306 | FB | FA | 15-A352-FB-FA |
| | | | W1 | L1 | 15-A352-W1-L1 |
| | | | 60 | EZ | 15-A352-60-EZ |
| DALI-2 / PUSH 220-240V | 3000 | 1306 | FB | FA | 15-A353-FB-FA |
| | | | W1 | L1 | 15-A353-W1-L1 |
| | | | 60 | EZ | 15-A353-60-EZ |
| PHASE CUT 220-240V | 4000 | 1342 | FB | FA | 15-A354-FB-FA |
| | | | W1 | L1 | 15-A354-W1-L1 |
| | | | 60 | EZ | 15-A354-60-EZ |
| DALI-2 / PUSH 220-240V | 4000 | 1342 | FB | FA | 15-A355-FB-FA |
| | | | W1 | L1 | 15-A355-W1-L1 |
| | | | 60 | EZ | 15-A355-60-EZ |

Gong Ø340 Opal

| |
|----------|
| BODY MAT |
| ST |

| |
|---------|
| DIF MAT |
| PMMA |



LED | CRI 92 | W Totals 15

181

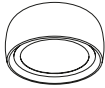

Ø342

| | K | Real Lm | Ring | Screen | Code |
|---------------------------|------|---------|------|--------|----------------------|
| PHASE CUT 220-240V | 2700 | 816 | FB | FA | 15-A356-FB-FA |
| | | | W1 | L1 | 15-A356-W1-L1 |
| | | | 60 | EZ | 15-A356-60-EZ |
| DALI-2 / PUSH 220-240V | 2700 | 816 | FB | FA | 15-A357-FB-FA |
| | | | W1 | L1 | 15-A357-W1-L1 |
| | | | 60 | EZ | 15-A357-60-EZ |
| PHASE CUT 220-240V | 3000 | 843 | FB | FA | 15-A358-FB-FA |
| | | | W1 | L1 | 15-A358-W1-L1 |
| | | | 60 | EZ | 15-A358-60-EZ |
| DALI-2 / PUSH 220-240V | 3000 | 843 | FB | FA | 15-A359-FB-FA |
| | | | W1 | L1 | 15-A359-W1-L1 |
| | | | 60 | EZ | 15-A359-60-EZ |
| PHASE CUT 220-240V | 4000 | 865 | FB | FA | 15-A360-FB-FA |
| | | | W1 | L1 | 15-A360-W1-L1 |
| | | | 60 | EZ | 15-A360-60-EZ |
| DALI-2 / PUSH 220-240V | 4000 | 865 | FB | FA | 15-A361-FB-FA |
| | | | W1 | L1 | 15-A361-W1-L1 |
| | | | 60 | EZ | 15-A361-60-EZ |

Los acabados y tonalidad mostrados pueden no ser completamente precisos debido a ligeras variaciones en la producción, factores de iluminación fotográficas e impresión.
Os acabamentos e tonalidades apresentados podem não ser totalmente precisos, devido a ligeiras variações na produção, fatores de iluminação fotográfica e de impressão.

| | | | |
|--------------------|--------------------|--------------|----|
| Gris Seda | Cinzeno Seda | FB | |
| Tejido Crema | Tecido Creme | FA | |
| Marrón Caoba | Castanho Caoba | W1 | |
| Terracota jaspeado | Terracota jaspeado | L1 | |
| | Negro Preto | 60 | |
| | Tejido Negro | Tecido Preto | EZ |

Gong Ø600 Microprisma



LED | CRI 92

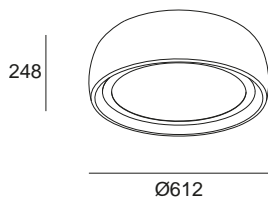

| | K | W Total / Real Lm | Ring | Screen | Code |
|---------------------------|------|-------------------|------|--------|----------------------|
| PHASE CUT 220-240V | 2700 | 34.7W / 2088lm | FB | FA | 15-8902-FB-FA |
| | | | W1 | L1 | 15-8902-W1-L1 |
| | | | 60 | EZ | 15-8902-60-EZ |
| DALI-2 / PUSH 220-240V | 2700 | 36.5W / 2570lm | FB | FA | 15-A366-FB-FA |
| | | | W1 | L1 | 15-A366-W1-L1 |
| | | | 60 | EZ | 15-A366-60-EZ |
| PHASE CUT 220-240V | 3000 | 34.7W / 2088lm | FB | FA | 15-8933-FB-FA |
| | | | W1 | L1 | 15-8933-W1-L1 |
| | | | 60 | EZ | 15-8933-60-EZ |
| DALI-2 / PUSH 220-240V | 3000 | 36.5W / 2660lm | FB | FA | 15-A367-FB-FA |
| | | | W1 | L1 | 15-A367-W1-L1 |
| | | | 60 | EZ | 15-A367-60-EZ |
| PHASE CUT 220-240V | 4000 | 34.7W / 2088lm | FB | FA | 15-8953-FB-FA |
| | | | W1 | L1 | 15-8953-W1-L1 |
| | | | 60 | EZ | 15-8953-60-EZ |
| DALI-2 / PUSH 220-240V | 4000 | 36.5W / 2731lm | FB | FA | 15-A368-FB-FA |
| | | | W1 | L1 | 15-A368-W1-L1 |
| | | | 60 | EZ | 15-A368-60-EZ |

Gong Ø600 Opal



LED | CRI 92

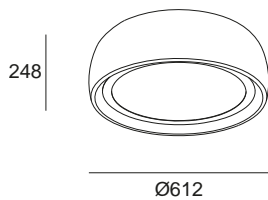

| | K | W Total / Real Lm | Ring | Screen | Code |
|---------------------------|------|-------------------|------|--------|----------------------|
| PHASE CUT 220-240V | 2700 | 34.7W / 1605lm | FB | FA | 15-A294-FB-FA |
| | | | W1 | L1 | 15-A294-W1-L1 |
| | | | 60 | EZ | 15-A294-60-EZ |
| DALI-2 / PUSH 220-240V | 2700 | 36.5W / 1946lm | FB | FA | 15-A297-FB-FA |
| | | | W1 | L1 | 15-A297-W1-L1 |
| | | | 60 | EZ | 15-A297-60-EZ |
| PHASE CUT 220-240V | 3000 | 34.7W / 1605lm | FB | FA | 15-A295-FB-FA |
| | | | W1 | L1 | 15-A295-W1-L1 |
| | | | 60 | EZ | 15-A295-60-EZ |
| DALI-2 / PUSH 220-240V | 3000 | 36.5W / 2017lm | FB | FA | 15-A298-FB-FA |
| | | | W1 | L1 | 15-A298-W1-L1 |
| | | | 60 | EZ | 15-A298-60-EZ |
| PHASE CUT 220-240V | 4000 | 34.7W / 1605lm | FB | FA | 15-A296-FB-FA |
| | | | W1 | L1 | 15-A296-W1-L1 |
| | | | 60 | EZ | 15-A296-60-EZ |
| DALI-2 / PUSH 220-240V | 4000 | 36.5W / 2069lm | FB | FA | 15-A299-FB-FA |
| | | | W1 | L1 | 15-A299-W1-L1 |
| | | | 60 | EZ | 15-A299-60-EZ |

Los acabados y tonalidad mostrados pueden no ser completamente precisos debido a ligeras variaciones en la producción, factores de iluminación fotográficas e impresión.

Os acabamentos e tonalidades apresentados podem não ser totalmente precisos, devido a ligeiras variações na produção, fatores de iluminação fotográfica e de impressão.







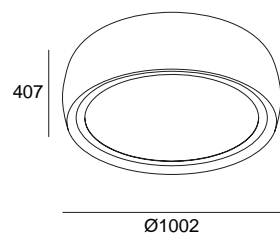







































| | | | | |
|--------------------|--------------------|--------------|----|--|
| Gris Seda | Cinzeno Seda | FB | | |
| Tejido Crema | Tecido Creme | FA | | |
| Marrón Caoba | Castanho Caoba | W1 | | |
| Terracota jaspeado | Terracota jaspeado | L1 | | |
| | Negro Preto | 60 | | |
| | Tejido Negro | Tecido Preto | EZ | |

Gong Ø1000 Microprisma

| | |
|----------|---------|
| BODY MAT | DIF MAT |
| ST | PMMA |



LED | CRI 92 | W Total 40







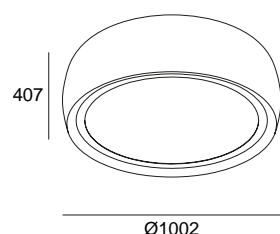







































| | K | Real Lm | Ring | Screen | Code |
|--|------|---------|--|--|--|
|  PHASE CUT 220-240V | 2700 | 3193 | FB  | FA  | 15-A338-FB-FA  |
| | | | W1  | L1  | 15-A338-W1-L1  |
| | | | 60  | EZ  | 15-A338-60-EZ  |
| DALI-2 / PUSH 220-240V | 2700 | 3193 | FB  | FA  | 15-A339-FB-FA |
| | | | W1  | L1  | 15-A339-W1-L1 |
| | | | 60  | EZ  | 15-A339-60-EZ |
| PHASE CUT 220-240V | 3000 | 3261 | FB  | FA  | 15-A340-FB-FA  |
| | | | W1  | L1  | 15-A340-W1-L1  |
| | | | 60  | EZ  | 15-A340-60-EZ  |
| DALI-2 / PUSH 220-240V | 3000 | 3261 | FB  | FA  | 15-A341-FB-FA |
| | | | W1  | L1  | 15-A341-W1-L1 |
| | | | 60  | EZ  | 15-A341-60-EZ |
| PHASE CUT 220-240V | 4000 | 3342 | FB  | FA  | 15-A342-FB-FA  |
| | | | W1  | L1  | 15-A342-W1-L1  |
| | | | 60  | EZ  | 15-A342-60-EZ  |
| DALI-2 / PUSH 220-240V | 4000 | 3342 | FB  | FA  | 15-A343-FB-FA |
| | | | W1  | L1  | 15-A343-W1-L1 |
| | | | 60  | EZ  | 15-A343-60-EZ |

Gong Ø1000 Opal

| | |
|----------|---------|
| BODY MAT | DIF MAT |
| ST | PMMA |





LED | CRI 92 | W Total 40

| | K | Real Lm | Ring | Screen | Code |
|--|------|---------|--|--|--|
|  PHASE CUT 220-240V | 2700 | 2341 | FB  | FA  | 15-A344-FB-FA  |
| | | | W1  | L1  | 15-A344-W1-L1  |
| | | | 60  | EZ  | 15-A344-60-EZ  |
| DALI-2 / PUSH 220-240V | 2700 | 2341 | FB  | FA  | 15-A345-FB-FA |
| | | | W1  | L1  | 15-A345-W1-L1 |
| | | | 60  | EZ  | 15-A345-60-EZ |
| PHASE CUT 220-240V | 3000 | 2394 | FB  | FA  | 15-A346-FB-FA  |
| | | | W1  | L1  | 15-A346-W1-L1  |
| | | | 60  | EZ  | 15-A346-60-EZ  |
| DALI-2 / PUSH 220-240V | 3000 | 2394 | FB  | FA  | 15-A347-FB-FA |
| | | | W1  | L1  | 15-A347-W1-L1 |
| | | | 60  | EZ  | 15-A347-60-EZ |
| PHASE CUT 220-240V | 4000 | 2454 | FB  | FA  | 15-A348-FB-FA  |
| | | | W1  | L1  | 15-A348-W1-L1  |
| | | | 60  | EZ  | 15-A348-60-EZ  |
| DALI-2 / PUSH 220-240V | 4000 | 2454 | FB  | FA  | 15-A349-FB-FA |
| | | | W1  | L1  | 15-A349-W1-L1 |
| | | | 60  | EZ  | 15-A349-60-EZ |

Los acabados y tonalidad mostrados pueden no ser completamente precisos debido a ligeras variaciones en la producción, factores de iluminación fotográficas e impresión.

Os acabamentos e tonalidades apresentados podem não ser totalmente precisos, devido a ligeiras variações na produção, fatores de iluminação fotográfica e de impressão.

| | | |
|---------------------------------------|----|---|
| Gris Seda Cinzento Seda | FB |  |
| Tejido Crema Tecido Creme | FA |  |
| Marrón Caoba Castanho Caoba | W1 |  |
| Terracota jaspeado Terracota jaspeado | L1 |  |
| Negro Preto | 60 |  |
| Tejido Negro Tecido Preto | EZ |  |

Spark



Performance Universe



P. 278



Inspiración nórdica

De inspiración nórdica, la sencillez de los elementos encuentra su razón de ser en la perfección de las formas y en sus combinaciones. Con distintas posibilidades de composición Spark propone un juego de volúmenes que se combinan alrededor de un perfil que pasa prácticamente desapercibido. Diseñada sin ataduras, sus posibilidades de instalación responden a su misma esencia de libertad.

Inspiração nórdica

De inspiração nórdica, a simplicidade dos elementos encontra a sua razão de ser na perfeição das formas e nas suas combinações. Com diferentes possibilidades de composição Spark propõe um jogo de volumes que se combinam em torno de um perfil que passa praticamente despercebido. Concebida sem laços, as suas possibilidades de instalação respondem à sua própria essência de liberdade.





Los tres cuerpos lumínicos generan tres volúmenes diferenciados.
Os três corpos luminicos geram três volumes diferenciados.

Spark Single Ø140mm

| | | | |
|----------|---------|--|----------------|
| BODY MAT | DIF MAT | | SWITCH CCT |
| ST | GLA | | 2700-3000-4000 |

Negro Preto 05 ●
Arenado Areado F9 ○

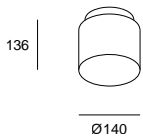

LED | K 2700-3000-4000 | CRI 92 | W Total 10 | Real Lm 424 (3000K)

| | Structure | Difussor | Code |
|--------------------|-----------|----------|---------------|
| PHASE CUT 220-240V | 05 ● | F9 ○ | 15-A125-05-F9 |

Spark Single Ø240mm

| | | | |
|----------|---------|--|----------------|
| BODY MAT | DIF MAT | | SWITCH CCT |
| ST | GLA | | 2700-3000-4000 |

Negro Preto 05 ●
Arenado Areado F9 ○

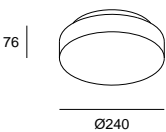

LED | K 2700-3000-4000 | CRI 92 | W Total 16 | Real Lm 652 (3000K)

| | Structure | Difussor | Code |
|--------------------|-----------|----------|---------------|
| PHASE CUT 220-240V | 05 ● | F9 ○ | 15-A126-05-F9 |

Spark Single Ø390mm

| | | | |
|----------|---------|--|----------------|
| BODY MAT | DIF MAT | | SWITCH CCT |
| ST | GLA | | 2700-3000-4000 |

Negro Preto 05 ●
Arenado Areado F9 ○

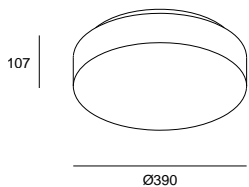

LED | K 2700-3000-4000 | CRI 92 | W Total 43.7 | Real Lm 2083 (3000K)

| | Structure | Difussor | Code |
|---------------|-----------|----------|---------------|
| DALI 220-240V | 05 ● | F9 ○ | 15-A127-05-F9 |



Desarrollado de forma minuciosa para conseguir un vidrio de calidad y un perfil muy fino con las mejores prestaciones técnicas.

Desenvolvido de forma minuciosa para conseguir um vidro de qualidade e um perfil muito fino com as melhores prestações técnicas.

Spark Double Ø390mm + Ø140mm

| | | | |
|----------|---------|--|----------------|
| BODY MAT | DIF MAT | | SWITCH CCT |
| ST | GLA | | 2700-3000-4000 |

Negro Preto 05 ●
Arenado Areado F9 ○

LED | K 2700-3000-4000 | CRI 92 | W Total 53.5 | Real Lm 2507 (3000K)

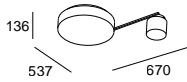

| | Structure | Difussor | Code |
|--|---------------|-----------|---------------|
| | DALI 220-240V | 05 ● F9 ○ | 15-A128-05-F9 |

Spark Double Ø390mm + Ø240mm

| | | | |
|----------|---------|--|----------------|
| BODY MAT | DIF MAT | | SWITCH CCT |
| ST | GLA | | 2700-3000-4000 |

Negro Preto 05 ●
Arenado Areado F9 ○

LED | K 2700-3000-4000 | CRI 92 | W Total 60.5 | Real Lm 2735 (3000K)

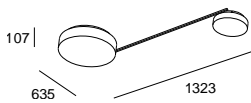

| | Structure | Difussor | Code |
|--|---------------|-----------|---------------|
| | DALI 220-240V | 05 ● F9 ○ | 15-A129-05-F9 |

Spark Triplex Ø390mm + Ø240mm + Ø140mm

| | | | |
|----------|---------|--|----------------|
| BODY MAT | DIF MAT | | SWITCH CCT |
| ST | GLA | | 2700-3000-4000 |

Negro Preto 05 ●
Arenado Areado F9 ○

LED | K 2700-3000-4000 | CRI 92 | W Total 68.5 | Real Lm 3159 (3000K)

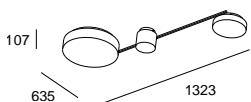

| | Structure | Difussor | Code |
|--|---------------|-----------|---------------|
| | DALI 220-240V | 05 ● F9 ○ | 15-A130-05-F9 |

Caprice



Performance Universe



P. 168



Eficiencia lumínica

Caprice ofrece diversidad de funciones avanzadas en un producto decorativo que se adapta a ambientes con grandes exigencias lumínicas.

Eficiência lumínica

Caprice oferece diversidade de funções avançadas num produto decorativo que se adapta a ambientes com grandes exigências lumínicas.



2700K

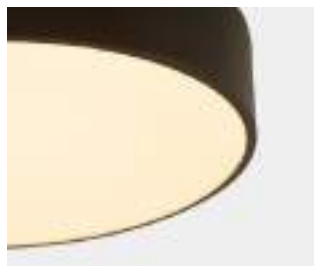

3000K



4000K

Cuenta con un switch integrado.
Possui um switch integrado.

Caprice ø240mm

QS

| | | | |
|----------|---------|--|----------------|
| BODY MAT | DIF MAT | | SWITCH CCT |
| ST | ACR | | 2700-3000-4000 |

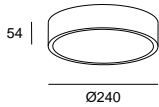

LED | K 2700-3000-4000 | CRI 92 | W Total 14.1 | Real Lm 896 (3000K)

Blanco Branco 14
Negro Preto 60
Blanco opal Branco opalino M1

| | Body | Difusor | Code |
|--------------------|---|--|--|
| PHASE CUT 220-240V | 14 <input type="radio"/> 60 <input checked="" type="radio"/> | M1 <input type="radio"/> M1 <input type="radio"/> | 15-6196-14-M1 15-6196-60-M1 |

Acabados The Colours bajo pedido mínimo de 15 unidades. Consultar precios en tarifa y plazos de entrega con equipo comercial.
Acabamentos The Colours sujeitos a encomenda mínima de 15 unidades. Consultar preços e prazos de entrega com a nossa equipa comercial.

Body: DL Oro Ouro Difusor: M1 Blanco opal Branco opalino

Caprice ø330mm

QS

| | | | |
|----------|---------|--|----------------|
| BODY MAT | DIF MAT | | SWITCH CCT |
| ST | ACR | | 2700-3000-4000 |

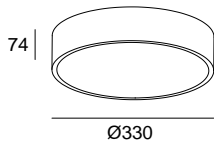

LED | K 2700-3000-4000 | CRI 92 | W Total 20 | Real Lm 1258 (3000K)

Blanco Branco 14
Negro Preto 60
Blanco opal Branco opalino M1

| | Body | Difusor | Code |
|--------------------|---|--|--|
| PHASE CUT 220-240V | 14 <input type="radio"/> 60 <input checked="" type="radio"/> | M1 <input type="radio"/> M1 <input type="radio"/> | 15-6197-14-M1 15-6197-60-M1 |

Acabados The Colours bajo pedido mínimo de 15 unidades. Consultar precios en tarifa y plazos de entrega con equipo comercial.
Acabamentos The Colours sujeitos a encomenda mínima de 15 unidades. Consultar preços e prazos de entrega com a nossa equipa comercial.

Body: DL Oro Ouro Difusor: M1 Blanco opal Branco opalino

Caprice ø520mm

QS

| | | | |
|----------|---------|--|----------------|
| BODY MAT | DIF MAT | | SWITCH CCT |
| ST | ACR | | 2700-3000-4000 |

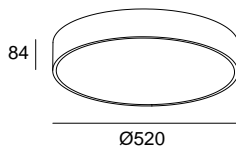

LED | K 2700-3000-4000 | CRI 92 | W Total 39.6 | Real Lm 3072 (3000K)

Blanco Branco 14
Negro Preto 60
Blanco opal Branco opalino M1

| | Body | Difusor | Code |
|--------------------|---|--|--|
| PHASE CUT 220-240V | 14 <input type="radio"/> 60 <input checked="" type="radio"/> | M1 <input type="radio"/> M1 <input type="radio"/> | 15-6433-14-M1 15-6433-60-M1 |

Acabados The Colours bajo pedido mínimo de 15 unidades. Consultar precios en tarifa y plazos de entrega con equipo comercial.
Acabamentos The Colours sujeitos a encomenda mínima de 15 unidades. Consultar preços e prazos de entrega com a nossa equipa comercial.

Body: DL Oro Ouro Difusor: M1 Blanco opal Branco opalino

MISO



Essential Universe



P. 309



Una opción esencial con distintas combinaciones

De líneas suaves y discretas, Miso es un plafón esencial que se adapta a todos los espacios. Con dos medidas disponibles, ofrece una enorme flexibilidad de acabados gracias a la combinación de acabados de su estructura interior y exterior.

Uma opção essencial com diferentes combinações

Com linhas suaves e discretas, Miso é um plafon essencial que se adapta a todos os espaços. Com dois tamanhos disponíveis, oferece uma enorme flexibilidade de acabamentos graças à combinação de acabamentos da sua estrutura interior e exterior.



15-8330-05-14



15-8330-05-DL



15-8330-14-DL



7 combinaciones de color posibles en 2 tamaños distintos.

7 combinações de cor possíveis em 2 tamanhos diferentes.

Miso 285mm

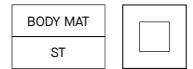

Blanco Branco 14 ○
 Negro Preto 05 ●
 Oro Ouro DL ○

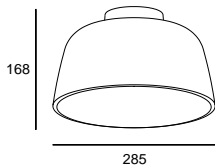

E27 | W Max. 15

Exterior Screen Interior Screen

Code

| | |
|------|------|
| 05 ● | 14 ○ |
| 05 ● | DL ○ |
| 14 ○ | 14 ○ |
| 14 ○ | DL ○ |

| |
|--------------------------------|
| 15-8330-05-14 |
| 15-8330-05-DL QS |
| 15-8330-14-14 QS |
| 15-8330-14-DL |

*Bombilla no incluida.
 *Lâmpada não incluida.

Acabados The Colours bajo pedido mínimo de 15 unidades. Consultar precios en tarifa y plazos de entrega con equipo comercial.
 Acabamentos The Colours sujeitos a encomenda mínima de 15 unidades. Consultar preços e prazos de entrega com a nossa equipa comercial.

Exterior Screen: ○ DL Oro Ouro Interior Screen: ○ 14 Blanco Branco

Miso 433mm

QS

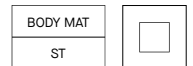

Blanco Branco 14 ○
 Negro Preto 05 ●
 Oro Ouro DL ○
 Gris piedra Cinzento pedra EM ○

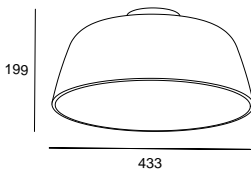

E27 | W Max. 15

Exterior Screen Interior Screen

Code

| | |
|------|------|
| 05 ● | DL ○ |
| 14 ○ | 14 ○ |
| 14 ○ | DL ○ |

| |
|----------------------|
| 15-8331-05-DL |
| 15-8331-14-14 |
| 15-8331-14-DL |

*Bombilla no incluida.
 *Lâmpada não incluida.

Acabados The Colours bajo pedido mínimo de 15 unidades. Consultar precios en tarifa y plazos de entrega con equipo comercial.
 Acabamentos The Colours sujeitos a encomenda mínima de 15 unidades. Consultar preços e prazos de entrega com a nossa equipa comercial.

Exterior Screen: ○ DL Oro Ouro Interior Screen: ○ 14 Blanco Branco

Bol



Performance Universe



P. 177



Bol Ø450mm

QS

BODY MAT
ST

DIF MAT
ACR,TEX

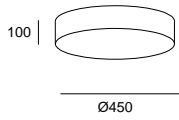

LED | K 3000 | CRI 80 | W Total 23 | Real Lm 1064

Arena Areia BY ●
Blanco opal Branco opalino M1 ○



Body

Difussor

Code

ON-OFF 100-240V

BY ●

M1 ○

15-4922-BY-M1

Bol Ø700mm

QS

BODY MAT
ST

DIF MAT
ACR,TEX

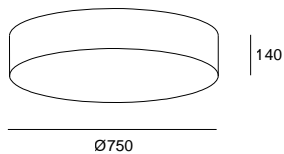

LED | K 3000 | CRI 80 | W Total 33 | Real Lm 1646

Arena Areia BY ●



Body

Code

ON-OFF 220-240V

BY ●

15-A052-BY-M1

Vetro



Performance Universe

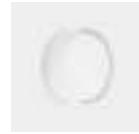

P. 311



P. 370



Un clásico con un vidrio prensado de doble grosor especial.

Um clássico com um vidro prensado de dupla espessura especial.



Vetro

QS

| | | | |
|----------|---------|--|----|
| BODY MAT | DIF MAT | | IP |
| ST | GLA | | 44 |

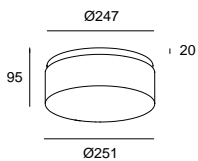

LED | K 3000 | CRI 80 | W Total 22.4 | Real Lm 1240

Blanco Branco 14
Cristal pintado blanco interior G5
Vidro pintado branco interior

| | Body | Difussor | Code |
|-----------------|--------------------------|-------------------------------------|----------------------|
| ON-OFF 220-240V | 14 <input type="radio"/> | G5 <input checked="" type="radio"/> | 05-7387-14-G5 |

Prolix



Performance Universe



P. 154



P. 294



Estilo y elegancia

Prolix plafón se adapta a los ambientes no sólo por la elegancia de su silueta facetada y la pureza de sus acabados dorado y negro mate, sino también por la adaptabilidad del efecto de luz gracias a la rotación de su estructura y sus ejes focales. Además, la óptica puede regularse de forma manual con un zoom ajustable de 15° a 50°.

Estilo e elegância

O plafon Prolix adapta-se a qualquer ambiente não só pela elegância da sua silhueta facetada e pela pureza dos seus acabamentos dourado e preto mate, mas também pela adaptabilidade do efeito de luz graças à rotação da sua estrutura e aos seus eixos focais. Além disso, a ótica pode ser regulada de forma manual com um zoom ajustável de 15° a 50°.



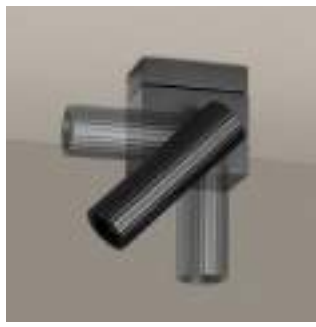

Óptica regulable para aumentar el ángulo de luz (Zoom 15°-50°).

Ótica regulável para aumentar o ângulo da luz (Zoom 15°-50°).

Prolix Double

QS

| | | | | |
|----------|---------|--|------|-----|
| BODY MAT | DIF MAT | | | |
| AL | PMMA | | 180° | 90° |

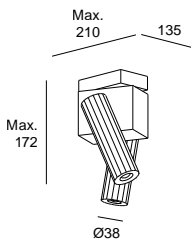

LED | K 2700 | CRI 92 | W Total 20 | Real Lm 639

Negro Preto 05 ●
Oro mate Ouro mate DN ●



PHASE CUT 220-240V

Structure Code

05 ● **15-8514-05-05**
DN ● **15-8514-DN-DN**

Simply



Essential Universe



P. 197



P. 230



Simply 1 body

QS

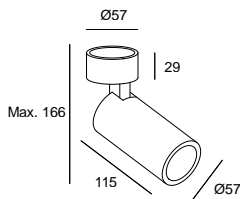

GU10 | W Max. 8

Blanco Branco 14
Negro Preto 05

Structure

Code

05
14

15-7982-05-05
15-7982-14-14

*Bombilla no incluida.
*Lâmpada não incluída.

Simply 2 bodies

QS

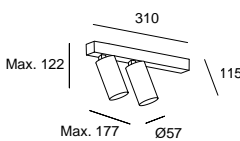

GU10 | W 2 × Max. 8

Blanco Branco 14
Negro Preto 05

Structure

Code

05
14

05-8335-05-05
05-8335-14-14

*Bombilla no incluida.
*Lâmpada não incluída.

Simply 3 bodies

QS

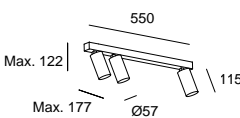

GU10 | W 3 × Max. 8

Blanco Branco 14
Negro Preto 05

Structure

Code

05
14

05-8336-05-05
05-8336-14-14

*Bombilla no incluida.
*Lâmpada não incluída.

Incluido
Incluido

Panel de abeja
Favo de abelha

Pipe



Essential Universe



P. 170



P. 196

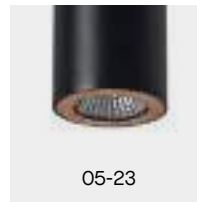

05-23



14-05

Combinaciones standard.
Combinações padrão.



14-14



05-05

Posibilidad de otras combinaciones mediante aros no incluidos.
Possibilidade de outras combinações por aros não incluídos.

Pipe Single

QS

| |
|----------|
| BODY MAT |
| ST,AL |



| | | |
|---------------|----|---|
| Blanco Branco | 14 | ○ |
| Negro Preto | 05 | ● |
| Oro Ouro | 23 | ● |

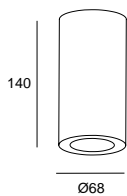

GU10 | W Max. 8

| Body | Ring | Code |
|------|------|---------------|
| 05 ● | 23 ● | 15-0073-05-23 |
| 14 ○ | 05 ● | 15-0073-14-05 |

*Bombilla no incluida.
*Lâmpada não incluída.

Acc. comunes no incluídos
Ac. comuns não incluídos

| | |
|------------|---------------|
| Aro blanco | 71-0073-14-14 |
| Aro branco | |
| Aro negro | 71-0073-05-05 |
| Aro preto | |

Stylus



Essential Universe



P. 172



P. 198



Stylus

| | | | | |
|----------|---------|--|--|--|
| BODY MAT | DIF MAT | | | |
| AL | PC | | | |

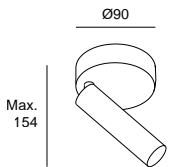

LED | K 3000 | CRI 92 | W Total 6.4 | Real Lm 364

Blanco Branco 14
 Negro Preto 05

| | Finishing | Code |
|--|-------------------------------------|----------------------|
| | 05 <input checked="" type="radio"/> | 05-5478-05-05 |
| | 14 <input type="radio"/> | 05-5478-14-14 |

ON-OFF 100-240V

Baño

Casa de banho



Perlina 358



Bloom 360



Dresde LED 362



Toi LED 364



Toilet Slim

366



Mist

368



Vetro

370



Dec

371



Vanity

372

Perlina



Performance Universe



P. 182



P. 220



P. 254



P. 276



Joya natural

Perlina se inspira en una joya natural para ofrecer una perla iluminada que juega con la esencia de la circunferencia, redonda y perfecta, dando sentido al minimalismo de lo básico. La opción con IP44, proporciona un efecto de luz tamizada a través de la esfera que transmite un sentimiento de calma llenando el espacio con naturalidad.

Joia natural

Perlina inspira-se numa joia natural para oferecer uma pérola iluminada que brinca com a essência da circunferência, redonda e perfeita, dando sentido ao minimalismo do básico. A opção com IP44 proporciona um efeito de luz filtrada através da esfera que transmite uma sensação de calma, enchendo o espaço de naturalidade.



Perlina IP44

QS

| | | | | |
|----------|---------|--|----|----------------|
| BODY MAT | DIF MAT | | IP | SWITCH CCT |
| AISI304 | GLA | | 44 | 2700-3000-4000 |

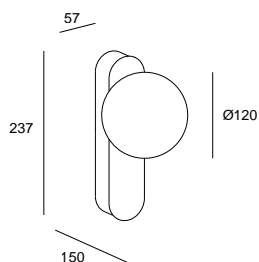

LED | K 2700-3000-4000 | CRI 92 | W Total 8.8 | Real Lm 391 (3000K)

Negro Preto 60 ●
Oro mate Ouro mate DN ●



ON-OFF 220-240V

DALI-2 220-240V

Structure Code

60 ● 05-A076-60-60
DN ● 05-A076-DN-DN

60 ● 05-A077-60-60
DN ● 05-A077-DN-DN

Bloom



Essential Universe



P. 288



Diseño amable y sencillez de las formas

La sencillez y la funcionalidad son a menudo la mejor carta de presentación. Bloom tiene un diseño amable, equilibrado en las formas, que la hacen destacar en el espacio precisamente por la suavidad de su perfil. Su desarrollo técnico, con un IP44, la convierten en una opción apta para la iluminación de baños.

Design amigável e simplicidade de formas

A simplicidade e a funcionalidade são muitas vezes a melhor carta de apresentação. Bloom tem um design amigável, equilibrado nas formas, o que a fazem sobressair no espaço precisamente devido à suavidade do seu perfil. O seu desenvolvimento técnico, com um IP44, torna-a uma opção adequada para a iluminação de casas de banho.



Bloom

QS

| | | | |
|----------|---------|--|----|
| BODY MAT | DIF MAT | | IP |
| ST | GLA | | 44 |

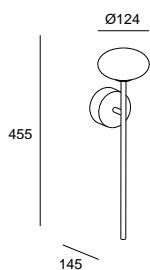

LED | K 2700 | CRI 92 | W Total 7.5 | Real Lm 262

Negro Preto 05 ●
Blanco opal Branco opalino M1 ○

| | Structure | Difussor | Code |
|-----------------|-----------|----------|---------------|
| ON-OFF 100-227V | 05 ● | M1 ○ | 05-A011-05-M1 |

QS Quick Service | 2-6 días laborables (tiempo de transporte no incluido)
Quick Service | 2-6 dias úteis (tempo de transporte não incluido)

Dresde LED



Performance Universe





Acabados en negro y níquel.
Acabamentos a preto e níquel.

Dresde LED

QS

| | | | |
|----------|---------|--|----|
| BODY MAT | DIF MAT | | IP |
| AL | GLA | | 44 |

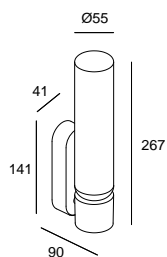

LED | K 3000 | CRI 92 | W Total 9.5 | Real Lm 563

Negro Preto 05 ●
Cromo Cromado 21 ●
Arenado Areado F9 ○

| | Structure | Difussor | Code |
|-----------------|-----------|----------|----------------------|
| | 05 ● | F9 ○ | 05-A012-05-F9 |
| ON-OFF 220-240V | 21 ● | F9 ○ | 05-A012-21-F9 |

QS Quick Service | 2-6 días laborables (tiempo de transporte no incluido)
Quick Service | 2-6 dias úteis (tempo de transporte não incluído)

Toi LED



Performance Universe





Toi LED Small

QS

| | | |
|----------|---------|----|
| BODY MAT | DIF MAT | IP |
| AL | PC | 44 |

Cromo Cromado 21
Blanco opal Branco opalino M1

LED | K 3000 | CRI 80 | W Total 8.7 | Real Lm 727

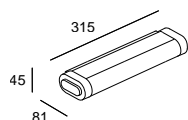

Structure

Difussor

Code

ON-OFF 220-240V

21

M1

05-7833-60-M1

Toi LED Medium

QS

| | | |
|----------|---------|----|
| BODY MAT | DIF MAT | IP |
| AL | PC | 44 |

Negro Preto 60
Cromo Cromado 21
Blanco opal Branco opalino M1

LED | K 3000 | CRI 80 | W Total 15.3 | Real Lm 1513

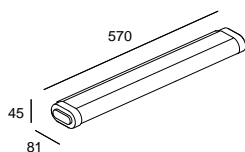

Structure

Difussor

Code

ON-OFF 220-240V

21
60

M1
M1

05-7833-21-M1
 05-7833-60-M1

Toilet Slim



Performance Universe



Toilet Slim 332mm

QS

| | | | |
|----------|---------|--|----|
| BODY MAT | DIF MAT |  | IP |
| AL | PC | | 44 |

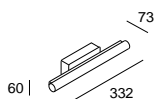

LED | K 3000 | CRI 92 | W Total 13.2 | Real Lm 880

Cromo Cromado 21
Blanco opal Branco opalino M1 

| | Structure | Difusor | Code |
|-----------------|-------------------------------------|--------------------------|----------------------|
| ON-OFF 220-240V | 21 <input checked="" type="radio"/> | M1 <input type="radio"/> | 05-A005-21-M1 |

Toilet Slim 632mm

QS

| | | | |
|----------|---------|---|----|
| BODY MAT | DIF MAT |  | IP |
| AL | PC | | 44 |

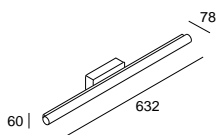

LED | K 3000 | CRI 92 | W Total 25 | Real Lm 1777

Cromo Cromado 21
Blanco opal Branco opalino M1 

| | Structure | Difusor | Code |
|-----------------|-------------------------------------|--------------------------|----------------------|
| ON-OFF 100-240V | 21 <input checked="" type="radio"/> | M1 <input type="radio"/> | 05-6396-21-M1 |

Toilet Slim 932mm

NEW

QS

| | | | |
|----------|---------|---|----|
| BODY MAT | DIF MAT |  | IP |
| AL | PC | | 44 |

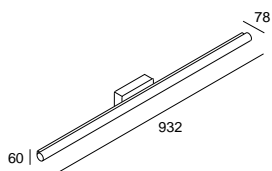

LED | K 3000 | CRI 92 | W Total 32.7 | Real Lm 2431

Cromo Cromado 21
Blanco opal Branco opalino M1 

| | Structure | Difusor | Code |
|-----------------|-------------------------------------|--------------------------|----------------------|
| ON-OFF 220-240V | 21 <input checked="" type="radio"/> | M1 <input type="radio"/> | 05-A102-21-M1 |

Mist



Essential Universe



P. 164



Sencillez y acierto

La sencillez de un diseño neutro que destaca la importancia de la bombilla. Mist es una colección de baño con distintas posibilidades de instalación que, gracias a esta característica y las opciones de acabados, ofrece una valorada riqueza compositiva.

Simplicidade e eficácia

A simplicidade de um design neutro que realça a importância da lâmpada. Mist é uma coleção de casa de banho com diferentes possibilidades de instalação que, graças a esta característica e às opções de acabamentos, oferece uma valiosa riqueza composicional.



Mist 1 body

QS

| | | | |
|----------|---------|--|----|
| BODY MAT | DIF MAT | | IP |
| ST | GLA | | 44 |

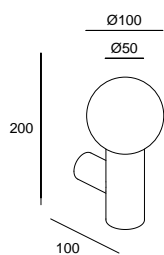

E14 Max. L 97 mm - Ø 35 mm | W Max. 9

Negro Preto 05 ●
 Cromo Cromado 21 ●
 Arenado Areado F9 ○

| Structure | Difussor | Code |
|-----------|----------|----------------------|
| 05 ● | F9 ○ | 05-8337-05-F9 |
| 21 ● | F9 ○ | 05-8337-21-F9 |

Mist Pendant

QS

| | | | |
|----------|---------|--|----|
| BODY MAT | DIF MAT | | IP |
| ST | GLA | | 44 |

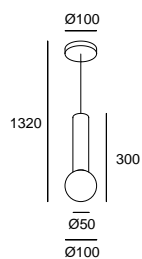

E14 Max. L 97 mm - Ø 35 mm | W Max. 9

Negro Preto 05 ●
 Cromo Cromado 21 ●
 Arenado Areado F9 ○

| Structure | Difussor | Code |
|-----------|----------|----------------------|
| 05 ● | F9 ○ | 00-8337-05-F9 |
| 21 ● | F9 ○ | 00-8337-21-F9 |

Vetro



Performance Universe



P. 311



P. 349



Un clásico con un vidrio prensado de doble grosor especial.

Um clássico com um vidro prensado de dupla espessura especial.



Vetro

QS

| | | | |
|----------|---------|--|----|
| BODY MAT | DIF MAT | | IP |
| ST | GLA | | 44 |

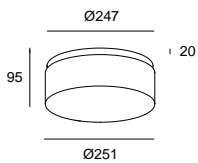

LED | K 3000 | CRI 80 | W Total 22.4 | Real Lm 1240

Blanco Branco 14
 Cristal pintado blanco interior G5
 Vidro pintado branco interior



ON-OFF 220-240V

Structure

14

Difussor

G5

Code

05-7387-14-G5

Dec



Essential Universe



Dec

QS

| | | | |
|----------|---------|--|----|
| BODY MAT | DIF MAT | | IP |
| ST | GLA | | 44 |

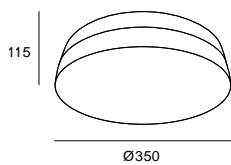

E27 | W 2 × Max. 15

Cromo Cromado 21

Arenado Areado F9

Structure **Difussor**

21 F9

Code

15-4370-21-F9

*Bombilla no incluida.
*Lâmpada não incluida.

Vanity



Performance Universe



Diseño contemporáneo

Espejo de baño con un diseño especial contemporáneo y muy atractivo.

Design contemporâneo

Espelho de casa de banho com um design especial contemporâneo e muito atrativo.



Vanity ofrece un gran confort gracias a su suave rotación y su regulación dimable.

Vanity oferece um grande conforto graças à sua rotação suave e à sua regulação dimmable.

Vanity

QS

| | | | | | | | |
|----------|---------|--|----|------|------|----|-----|
| BODY MAT | DIF MAT | | IP | | | | |
| AL | MIR | | 44 | 150° | 180° | x3 | DIM |

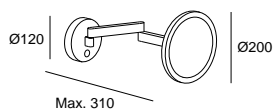

LED | K 3000 | CRI 92 | W Total 10.5 | Real Lm 256



TOUCH DIMMING 100-240V

Structure

Body

Code

05 ●
21 ○

K3 ○
K3 ○

75-8508-05-K3
75-8508-21-K3

Negro Preto 05 ●
Cromo Cromado 21 ○
Cristal espejo Vidro espelho K3 ○

Fans

Ventilación
Forlight by LedsC4

Ventilação
Forlight by LedsC4









Ventilación

Ventilação



Stem Evo

382



Marinada

394



Bosc

396



Pam

398



Bora

402



Calar

404



Helix

400



Garbi

406



July

408



Shadow

410

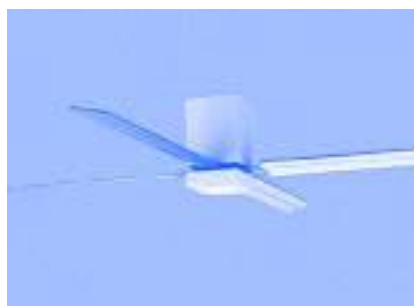

Zonda

412

Stem Evo NEW

Performance Collection



Diseño pensado para el bienestar

La silueta orgánica y los acabados nobles de Stem Evo envuelven el aire con suavidad, integrándose de forma natural en interiores que priorizan la calma y el diseño. Su presencia es sutil pero intencionada: acompaña sin imponerse, refresca en silencio y aporta una belleza serena que transforma cada espacio.

Gracias a sus múltiples combinaciones, Stem Evo se adapta a cada ambiente manteniendo intacta su esencia: equilibrio, funcionalidad y una elegancia atemporal pensada para perdurar.

Design pensado para o bem-estar

A silhueta orgânica e os acabamentos nobres de Stem Evo envolvem o ar com suavidade, integrando-se de forma natural em interiores que privilegiam a calma e o design. A sua presença é subtil, mas intencional: acompanha sem se impor, refresca em silêncio e proporciona uma beleza serena que transforma cada espaço.

Graças às suas múltiplas combinações, Stem Evo adapta-se a cada ambiente, mantendo intacta a sua essência: equilíbrio, funcionalidade e uma elegância intemporal pensada para durar.



Configura tu Stem Evo

Configure a sua Stem Evo

Configuración personalizable, pensada para integrarse con elegancia y originalidad a cualquier proyecto.
Configuração personalizável, concebida para se integrar com elegância e originalidade em qualquer projeto.

1 Tamaño

Tamanho



Ø 1220



Ø 1320

2 Estructura

Estrutura



Pendant



Tube

3 Acabado de la estructura

Acabamento da estrutura



B
Blanco
Branco



N
Negro
Preto



S
Níquel satinado
Níquel escovado

4 Acabado de las palas

Acabamento das pás



BL
Blanco
Branco



FC
Madera natural
Madeira natural



NE
Negro
Preto



FF
Nogal oscuro
Nogueira escura

5 Iluminación

Iluminação



Sin luz
Sem luz



Con luz LED
Com luz LED



Kit Play Super Comfort

Ventilación e iluminación de altas prestaciones con el kit de luz Play, diseñadas para garantizar confort visual, eficiencia y bienestar.

Ventilação e iluminação de elevado desempenho com o kit de luz Play, concebidas para garantir o conforto visual, a eficácia e o bem-estar.



Stem Evo without light



Structure

- Blanco Branco
- Negro Preto
- Níquel satinado Níquel acetinado

Blades

- Blanco Branco BL
- Madeira natural Madeira natural FC
- Negro Preto NE
- Nogal oscuro Nogueira escura FF

Stem Evo

QS BODY MAT AISI316 | BLADES MAT SOLID WOOD | 20-32m² | DC MOTOR | AIRFLOW M 137 m³/min L 164 m³/min | Sun/Snow icons | Fan icon | Remote icon | No light icon

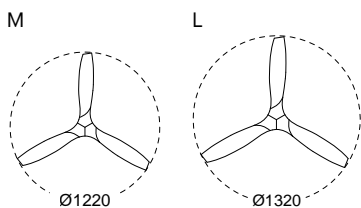
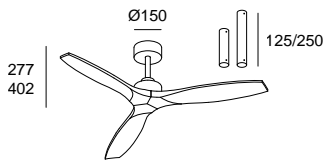

| W | Source | Side | Code | Structure | Blades | | |
|--------------|----------|----------|----------------|--|---|----------|----------|
| 30 | 100-240V | Ø 1220 | VE-0114 | B <input type="radio"/> - N <input checked="" type="radio"/> S <input type="radio"/> | BL <input type="radio"/> FC <input type="radio"/> NE <input checked="" type="radio"/> FF <input type="radio"/> | | |
| 30 | 100-240V | Ø 1320 | VE-0096 | B <input type="radio"/> - N <input checked="" type="radio"/> S <input type="radio"/> | BL <input type="radio"/> FC <input type="radio"/> NE <input checked="" type="radio"/> FF <input type="radio"/> | | |
| Speed | | | | | | | |
| RPM | | 1 | 2 | 3 | 4 | 5 | 6 |
| | | 82 | 106 | 123 | 148 | | 190 |

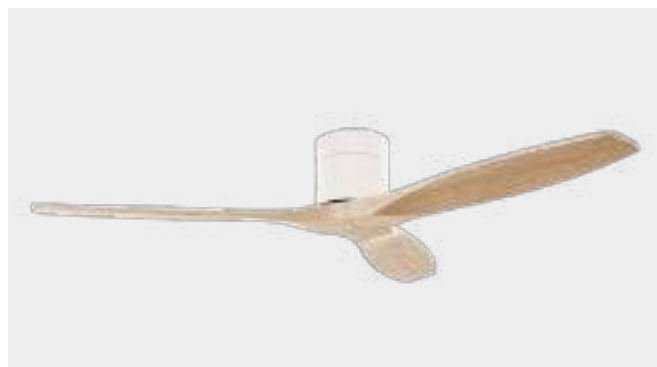

Structure

- Blanco Branco
- Negro Preto
- Níquel satinado Níquel acetinado

Blades

- Blanco Branco BL
- Madera natural Madeira natural FC
- Negro Preto NE
- Nogal oscuro Nogueira escura FF

Stem Evo Tube

QS

| | | | | | | | | | |
|---------------------|--------------------------|---------------------|--|-------------|---|--|--|--|--|
| BODY MAT AISI316 | BLADES MAT SOLID WOOD | 20-32m ² | | DC MOTOR | AIRFLOW M 137 m ³ /min L 164 m ³ /min | | | | |
|---------------------|--------------------------|---------------------|--|-------------|---|--|--|--|--|

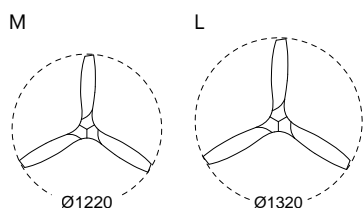
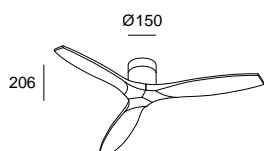

| W | Source | Side | Code | Structure | Blades | | |
|--------------|----------|----------|----------------|---|--|----------|----------|
| 30 | 100-240V | Ø 1220 | VE-0115 | B <input type="radio"/> - N <input type="radio"/> S <input type="radio"/> | BL <input type="radio"/> FC <input type="radio"/> NE <input type="radio"/> FF <input type="radio"/> | | |
| 30 | 100-240V | Ø 1320 | VE-0098 | B <input type="radio"/> - N <input type="radio"/> S <input type="radio"/> | BL <input type="radio"/> FC <input type="radio"/> NE <input type="radio"/> FF <input type="radio"/> | | |
| Speed | | 1 | 2 | 3 | 4 | 5 | 6 |
| RPM | | 82 | 106 | 123 | 148 | 190 | |

QS Quick Service | 2-6 días laborables (tiempo de transporte no incluido)
Quick Service | 2-6 dias úteis (tempo de transporte não incluído)

Stem Evo with light



Structure

- Blanco Branco
- Negro Preto
- Níquel satinado Níquel acetinado

Blades

- Blanco Branco BL
- Madera natural Madeira natural FC
- Negro Preto NE
- Nogal oscuro Nogueira escura FF

Stem Evo

| | | | | | | | | | | | |
|-----------|----------------------------|-------------------------|---------------------------------|--------------------|-------------|--|--|--|--|--------------------------------------|-----|
| QS | BODY MAT AISI316 | DIF MAT GLASS | BLADES MAT SOLID WOOD | M 13-20 L 20-32 | DC MOTOR | AIRFLOW M 137 m³/min L 164 m³/min | | | | SWITCH CCT 3000/4000/5000K | DIM |
|-----------|----------------------------|-------------------------|---------------------------------|--------------------|-------------|--|--|--|--|--------------------------------------|-----|

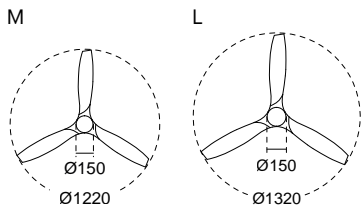
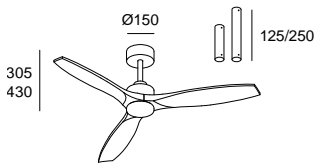

LED

| W | CRI | K | Real Lm | Source | Side | Code | Structure | Blades |
|----|-----|------|---------|------------|--------|---------|-------------------------|--------------------------|
| 50 | 50 | 3000 | 2875 | 100-240VAC | Ø 1220 | VE-0112 | B <input type="radio"/> | BL <input type="radio"/> |
| | | 4000 | | | | | N <input type="radio"/> | FC <input type="radio"/> |
| | | 5000 | | | | | S <input type="radio"/> | NE <input type="radio"/> |
| 50 | 50 | 3000 | 2875 | 100-240VAC | Ø 1320 | VE-0095 | B <input type="radio"/> | BL <input type="radio"/> |
| | | 4000 | | | | | N <input type="radio"/> | FC <input type="radio"/> |
| | | 5000 | | | | | S <input type="radio"/> | NE <input type="radio"/> |
| | | | | | | | | FF <input type="radio"/> |

El flujo indicado por cada óptica corresponde al de 4000K de Temperatura de color.
The luminous flux indicated for each optic corresponds to that of a 4000K color temperature.

| Speed | 1 | 2 | 3 | 4 | 5 | 6 |
|-------|----|-----|-----|-----|---|-----|
| RPM | 82 | 106 | 123 | 148 | | 190 |



Structure

- Blanco Branco
- Negro Preto
- Níquel satinado Níquel acetinado

Blades

- Blanco Branco BL
- Madera natural Madeira natural FC
- Negro Preto NE
- Nogal oscuro Nogueira escura FF

Stem Evo Tube

QS

| | | | | | | | | | | | | | |
|---------------------|------------------|--------------------------|--------------------|--|-------------|---|--|--|--|--|-------------------------------|--|-----|
| BODY MAT AISI316 | DIF MAT GLASS | BLADES MAT SOLID WOOD | M 13-20 L 20-32 | | DC MOTOR | AIRFLOW M 137 m³/min L 164 m³/min | | | | | SWITCH CCT 3000/4000/5000K | | DIM |
|---------------------|------------------|--------------------------|--------------------|--|-------------|---|--|--|--|--|-------------------------------|--|-----|

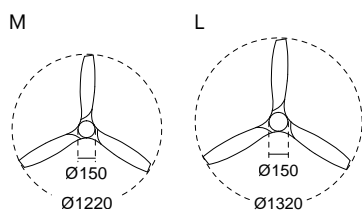
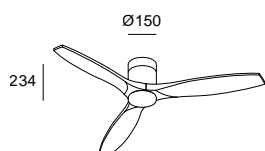

LED

| W | CRI | K | Real Lm | Source | Side | Code | Structure | Blades |
|----|------|------|---------|------------|--------|---------|--------------------------------------|--------------------------|
| 50 | 4000 | 3000 | 2875 | 100-240VAC | Ø 1220 | VE-0113 | B <input type="radio"/> | BL <input type="radio"/> |
| | | 4000 | | | | | - N <input checked="" type="radio"/> | FC <input type="radio"/> |
| | | 5000 | | | | | S <input type="radio"/> | NE <input type="radio"/> |
| 50 | 4000 | 3000 | 2875 | 100-240VAC | Ø 1320 | VE-0097 | B <input type="radio"/> | BL <input type="radio"/> |
| | | 4000 | | | | | - N <input checked="" type="radio"/> | FC <input type="radio"/> |
| | | 5000 | | | | | S <input type="radio"/> | NE <input type="radio"/> |
| | | | | | | | | FF <input type="radio"/> |

El flujo indicado por cada óptica corresponde al de 4000K de Temperatura de color.
The luminous flux indicated for each optic corresponds to that of a 4000K color temperature.

| Speed | 1 | 2 | 3 | 4 | 5 | 6 |
|-------|----|-----|-----|-----|---|-----|
| RPM | 82 | 106 | 123 | 148 | | 190 |

Stem Evo with Play Super Comfort



Structure

- Blanco Branco
- Negro Preto
- Níquel satinado
- Níquel acetinado

Blades

- Blanco Branco BL
- Madera natural Madeira natural FC
- Negro Preto NE
- Nogal oscuro Nogueira escura FF

Stem Evo

QS
 BODY MAT AISI316
 DIF MAT GLASS
 BLADES MAT SOLID WOOD
 M 13-20m²
 L 20-32m²
 DC MOTOR
 AIRFLOW L 164 m³/min M 137 m³/min
 Sun/Snow
 Wave
 Speaker
 Remote Control

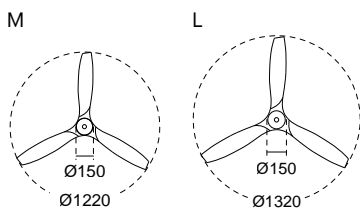
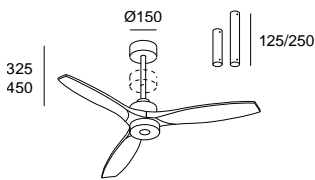

LED

| W | CRI | K | Real Lm | Optics | Source | Side | Code | Structure | Blades |
|-------|------|------|---------|--------|------------|-------|----------------|---|--|
| 42.1 | 2700 | 1350 | | | 100-240VAC | Ø1220 | VE-0120 | B <input type="radio"/> N <input type="radio"/> S <input type="radio"/> | BL <input type="radio"/> FC <input type="radio"/> NE <input type="radio"/> FF <input type="radio"/> |
| 42.1 | 2700 | 1350 | | | 100-240VAC | Ø1320 | VE-0118 | B <input type="radio"/> N <input type="radio"/> S <input type="radio"/> | BL <input type="radio"/> FC <input type="radio"/> NE <input type="radio"/> FF <input type="radio"/> |
| Speed | 1 | 2 | 3 | 4 | 5 | 6 | | | |
| RPM | 82 | 106 | 123 | 148 | | 190 | | | |



Structure

- Blanco Branco
- Negro Preto
- Níquel satinado Níquel acetinado

Blades

- Blanco Branco BL
- Madera natural Madeira natural FC
- Negro Preto NE
- Nogal oscuro Nogueira escura FF

Stem Evo Tube

QS

| | | | | | | | | | | | |
|---------------------|------------------|--------------------------|---------------------|---------------------|--|-------------|---|--|--|--|--|
| BODY MAT AISI316 | DIF MAT GLASS | BLADES MAT SOLID WOOD | 13-20m ² | 20-32m ² | | DC MOTOR | AIRFLOW L 164 m ³ /min M 137 m ³ /min | | | | |
|---------------------|------------------|--------------------------|---------------------|---------------------|--|-------------|---|--|--|--|--|

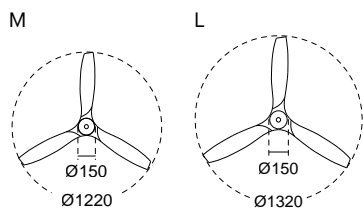
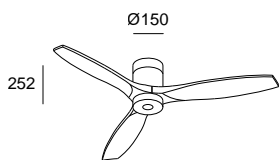

LED

| W | CRI | K | Real Lm | Optics | Source | Side | Code | Structure | Blades |
|------|------|------|---------|--------|------------|--------|----------------|---|--|
| 42.1 | 2700 | 1350 | | | 100-240VAC | Ø 1220 | VE-0121 | B <input type="radio"/> N <input type="radio"/> S <input type="radio"/> | BL <input type="radio"/> FC <input type="radio"/> NE <input type="radio"/> FF <input type="radio"/> |

| | | | | | | | | | |
|------|------|------|--|--|------------|--------|----------------|---|--|
| 42.1 | 2700 | 1350 | | | 100-240VAC | Ø 1320 | VE-0119 | B <input type="radio"/> N <input type="radio"/> S <input type="radio"/> | BL <input type="radio"/> FC <input type="radio"/> NE <input type="radio"/> FF <input type="radio"/> |
|------|------|------|--|--|------------|--------|----------------|---|--|

Speed



| | 1 | 2 | 3 | 4 | 5 | 6 |
|-----|----|-----|-----|-----|---|-----|
| RPM | 82 | 106 | 123 | 148 | | 190 |

QS Quick Service | 2-6 días laborables (tiempo de transporte no incluido)
 Quick Service | 2-6 dias úteis (tempo de transporte não incluido)



Accesorios

Acessórios

| | | | |
|---|------------------------------------|---------------|----------------------|
|  | 125mm / 250mm bar | | Included |
| | 500mm bar | 14 ○ | 71-B940-14-14 |
| | | 05 ● | 71-B940-05-05 |
| | | 81 ● | 71-B940-81-81 |
|  | White wall controller for DC motor | Light | 71-C340-14-14 |
| | | Without Light | 71-C341-14-14 |
|  | White wall controller for DC motor | Light | 71-C340-05-05 |
| | | Without Light | 71-C341-05-05 |



Marinada NEW

Performance Collection



Marinada

| | | | | | | | | | | |
|--|--------------------------|---------------------------|--|------------------------------|-------------|--|--|--------------------|--|--|
| | BODY MAT STEEL | BLADES MAT WOOD | | AIRFLOW 147 m³/min | 20-32m² | | | DC MOTOR | | |
|--|--------------------------|---------------------------|--|------------------------------|-------------|--|--|--------------------|--|--|

Structure

Blanco Branco

Reversible Blades

Blanco Branco 14

Madera natural Madeira natural

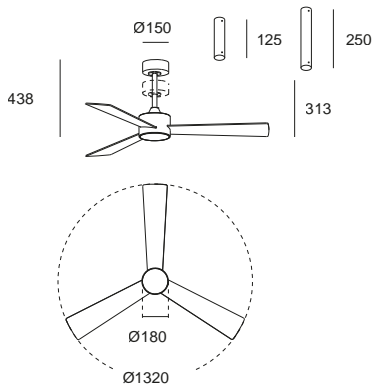

LED

| W | Source | Code | Structure | Blades |
|----|----------|---------------------|-----------------------|--|
| 35 | 220-240V | 30-A001 - 14 | <input type="radio"/> | - 14 <input type="radio"/> <input checked="" type="radio"/> |

| Speed | 1 | 2 | 3 | 4 | 5 | 6 |
|-------|-----|-----|-----|-----|---|-----|
| RPM | 112 | 140 | 165 | 187 | | 223 |

Accesorios
Acessórios

— 125mm / 250mm bar

Included



BOSC

Performance Collection



Bosc

QS

| | | | | | | | | | | | | |
|---------------------|--------------------|--------------------|-----------------------|--|-------------|--|--|-------------------------------|---------|-------------|--|--|
| BODY MAT AISI316 | DIF MAT ACRYLIC | BLADES MAT WOOD | AIRFLOW 138 m³/min | | 13-20m² | | | SWITCH CCT 3000/4000/5000K | DIM | DC MOTOR | | |
|---------------------|--------------------|--------------------|-----------------------|--|-------------|--|--|-------------------------------|---------|-------------|--|--|

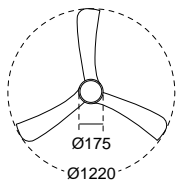
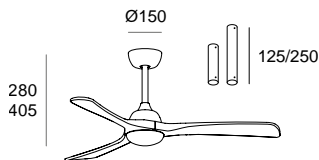

Negro Preto NEG ●
Nogal Nogueira ●

LED

| W | CRI | K | Real Lm | Source | Code | Structure | Blades |
|----|-----|------|---------|------------|-----------------|-----------|--------|
| 50 | 80 | 3000 | 2875 | 100-240VAC | VE-0092 - NEG ● | ● | ● |
| | | 4000 | | | | | |
| | | 5000 | | | | | |

El flujo indicado por cada óptica corresponde al de 4000K de Temperatura de color.
The luminous flux indicated for each optic corresponds to that of a 4000K color temperature.

| Speed | 1 | 2 | 3 | 4 | 5 | 6 |
|-------|----|-----|-----|-----|---|-----|
| RPM | 91 | 108 | 134 | 156 | | 200 |

QS Quick Service | 2-6 días laborables (tiempo de transporte no incluido)
Quick Service | 2-6 dias úteis (tempo de transporte não incluido)

Accesorios Acessórios

| | | | |
|--|---|------|---------------|
| | 125mm / 250mm bar | | Included |
| | 500mm bar | 05 ● | 71-B940-05-05 |
| | Black wall controller for DC motor with light | 14 ○ | 71-C340-14-14 |
| | White wall controller for DC motor with light | 05 ● | 71-C340-05-05 |



Pam

Performance Collection



| | | | | | | | | | | | | | |
|------------------|----------|---------|------------|------------|--|--|--|--|------------|--|-----------------|--|--|
| Pam QS | BODY MAT | DIF MAT | BLADES MAT | AIRFLOW | | | | | SWITCH CCT | | DC | | |
| | AISI316 | ACRYLIC | | 149 m³/min | | | | | 20-32m² | | 3000/4000/5000K | | |

Blanco Branco BLA

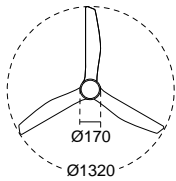
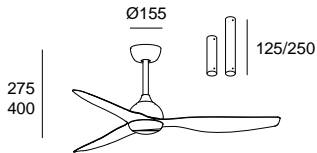

LED

| W | CRI | K | Real Lm | Source | Code | Structure | Blades |
|----|-----|------|---------|------------|----------------------|-----------------------|-----------------------|
| | | 3000 | | | | | |
| 50 | | 4000 | 2875 | 100-240VAC | VE-0091 - BLA | <input type="radio"/> | <input type="radio"/> |
| | | 5000 | | | | | |

El flujo indicado por cada óptica corresponde al de 4000K de Temperatura de color.
The luminous flux indicated for each optic corresponds to that of a 4000K color temperature.

| Speed | 1 | 2 | 3 | 4 | 5 | 6 |
|-------|----|-----|-----|-----|---|-----|
| RPM | 85 | 109 | 124 | 145 | | 193 |

QS Quick Service | 2-6 días laborables (tiempo de transporte no incluido)
Quick Service | 2-6 dias úteis (tempo de transporte não incluido)

Accesorios Acessórios

| | | | |
|--|---|-------------------------------------|----------------------|
| | 125mm / 250mm bar | | Included |
| | 500mm bar | 14 <input type="radio"/> | 71-B940-05-05 |
| | Black wall controller for DC motor with light | 14 <input type="radio"/> | 71-C340-14-14 |
| | White wall controller for DC motor with light | 05 <input checked="" type="radio"/> | 71-C340-05-05 |



Helix

Performance Collection



Helix

QS

| | | | | | | | | | | | | |
|-------------------|------------------|-------------------|-----------------------|--|-------------|--|--|-------------------------------|---------|-------------|--|--|
| BODY MAT STEEL | DIF MAT GLASS | BLADES MAT ABS | AIRFLOW 139 m³/min | | 20-32m² | | | SWITCH CCT 3000/4000/5000K | DIM | DC MOTOR | | |
|-------------------|------------------|-------------------|-----------------------|--|-------------|--|--|-------------------------------|---------|-------------|--|--|

Blanco Branco BLA

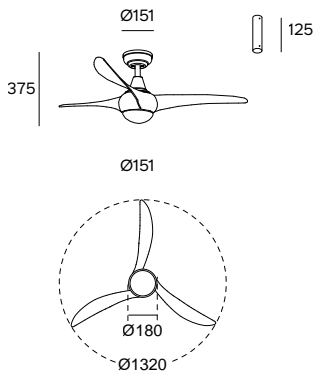

LED

| W | CRI | K | Real Lm | Source | Code | Structure | Blades |
|----|-----|------|---------|------------|---------------|-----------------------|-----------------------|
| | | 3000 | | | | | |
| 50 | | 4000 | 2875 | 100-240VAC | VE-0094 - BLA | <input type="radio"/> | <input type="radio"/> |
| | | 5000 | | | | | |

El flujo indicado por cada óptica corresponde al de 4000K de Temperatura de color.
The luminous flux indicated for each optic corresponds to that of a 4000K color temperature.

| Speed | 1 | 2 | 3 | 4 | 5 | 6 |
|-------|----|----|-----|-----|---|-----|
| RPM | 78 | 98 | 118 | 136 | | 180 |

QS Quick Service | 2-6 días laborables (tiempo de transporte no incluido)
Quick Service | 2-6 días úteis (tempo de transporte não incluido)

Accesorios

Acessórios

| | | | |
|--|---|-------------------------------------|---------------|
| | 125mm / 250mm bar | | Included |
| | 500mm bar | 14 <input type="radio"/> | 71-B940-05-05 |
| | Black wall controller for DC motor with light | 14 <input type="radio"/> | 71-C340-14-14 |
| | White wall controller for DC motor with light | 05 <input checked="" type="radio"/> | 71-C340-05-05 |



Designed by Jordi Blasi

Bora

Essential Collection

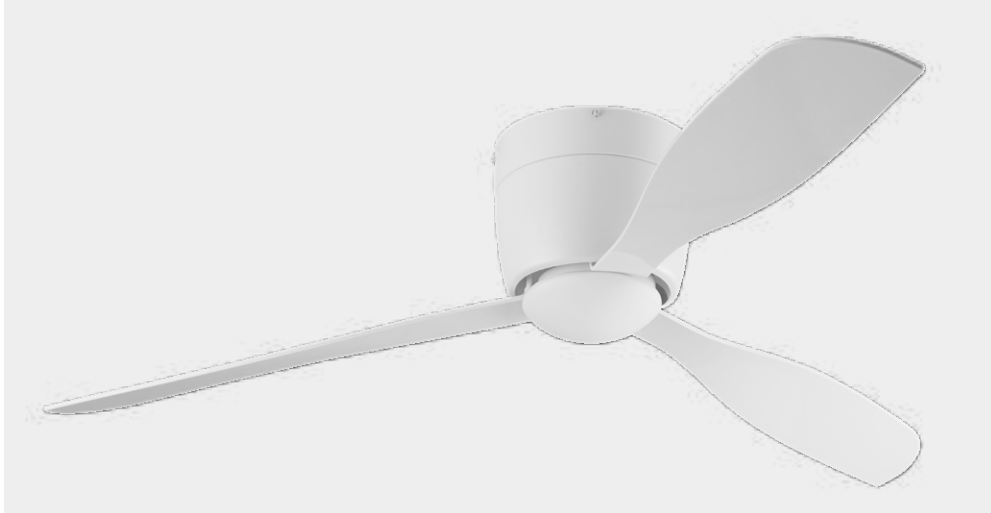

| | | | | | | | | | |
|----------|---------|---------------|--|------------|--|--|-------|--|--|
| BODY MAT | DIF MAT | BLADES MAT | | AIRFLOW | | | DC | | |
| STEEL | GLASS | POLYCARBONATE | | 116 m³/min | | | MOTOR | | |

Bora Ø988

QS

<13m²

Blanco Branco 14-F9

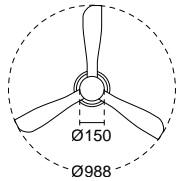
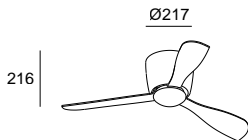

LED

| W | CRI K | Real Lm | Source | Side | Code | Structure | Blades |
|------|-------|---------|------------|-------|----------------|----------------------------|----------------------------|
| 38.1 | 3000 | 1800 | 100-240VAC | Ø 988 | 30-7973 | - 14 <input type="radio"/> | - F9 <input type="radio"/> |

Speed

| | 1 | 2 | 3 | 4 | 5 |
|-----|-----|-----|-----|-----|---|
| RPM | 160 | 175 | 190 | 215 | |

Bora Ø1235

QS

| | | |
|---------|-------------------------------|-----|
| 13-20m² | SWITCH CCT 2700/4000/6000K | DIM |
|---------|-------------------------------|-----|

Blanco Branco BLA

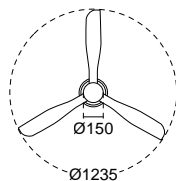
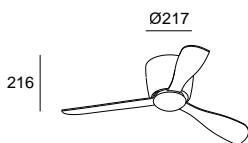

LED

| W | CRI K | Real Lm | Source | Side | Code | Structure | Blades |
|------|-------|---------|------------|--------|----------------|-----------------------------|-----------------------|
| 57.7 | 4000 | 975 | 100-240VAC | Ø 1235 | VE-0090 | - BLA <input type="radio"/> | <input type="radio"/> |
| | 2700 | | | | | | |
| | 6000 | | | | | | |

El flujo indicado por cada óptica corresponde al de 4000K de Temperatura de color.
The luminous flux indicated for each optic corresponds to that of a 4000K color temperature.

Speed

| | 1 | 2 | 3 | 4 | 5 |
|-----|-----|-----|-----|-----|---|
| RPM | 160 | 175 | 190 | 215 | |



Calar

Essential Collection



Calar

QS

| | | | | | | | | |
|------------------------|-------------------------|------------------------|--|--|--|-------------|--|--|
| BODY MAT STEEL / AL | DIF MAT METHACRYLATE | BLADES MAT FSC WOOD | | | | DC MOTOR | | |
|------------------------|-------------------------|------------------------|--|--|--|-------------|--|--|

Blanco Branco BLA
Madera natural Madeira natural

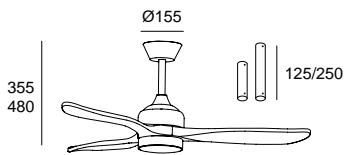

LED

| W | CRI K | Real Lm | Source | Side | Code | Structure | Blades |
|------|-------|---------|----------|--------|-------------------------------------|----------------------------------|--------|
| | 3000 | | | Ø 750 | VE-0022 | | |
| 38.1 | 4000 | 2570 | 200-240V | Ø 1066 | VE-0016 - BLA <input type="radio"/> | <input checked="" type="radio"/> | |
| | 5000 | | | Ø 1320 | VE-0023 | | |

El flujo indicado por cada óptica corresponde al de 4000K de Temperatura de color.
The luminous flux indicated for each optic corresponds to that of a 4000K color temperature.

| | |
|-------|------------|
| | AIRFLOW |
| <13m² | 137 m³/min |

| Speed | 1 | 2 | 3 | 4 | 5 |
|-------|----|-----|-----|-----|---|
| RPM | 83 | 147 | 213 | 283 | |

| | |
|------|------------|
| | AIRFLOW |
| 13m² | 131 m³/min |

| Speed | 1 | 2 | 3 | 4 | 5 |
|-------|----|-----|-----|-----|---|
| RPM | 82 | 122 | 164 | 208 | |

| | |
|---------|------------|
| | AIRFLOW |
| 20-32m² | 159 m³/min |

| Speed | 1 | 2 | 3 | 4 | 5 |
|-------|----|-----|-----|-----|---|
| RPM | 80 | 110 | 139 | 172 | |

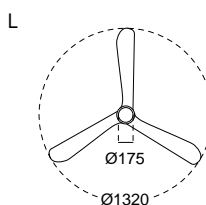
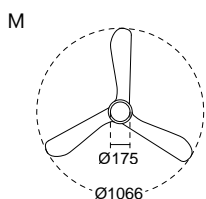
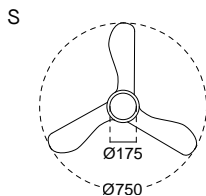



Designed by Jordi Blasi

Garbí

Performance Collection

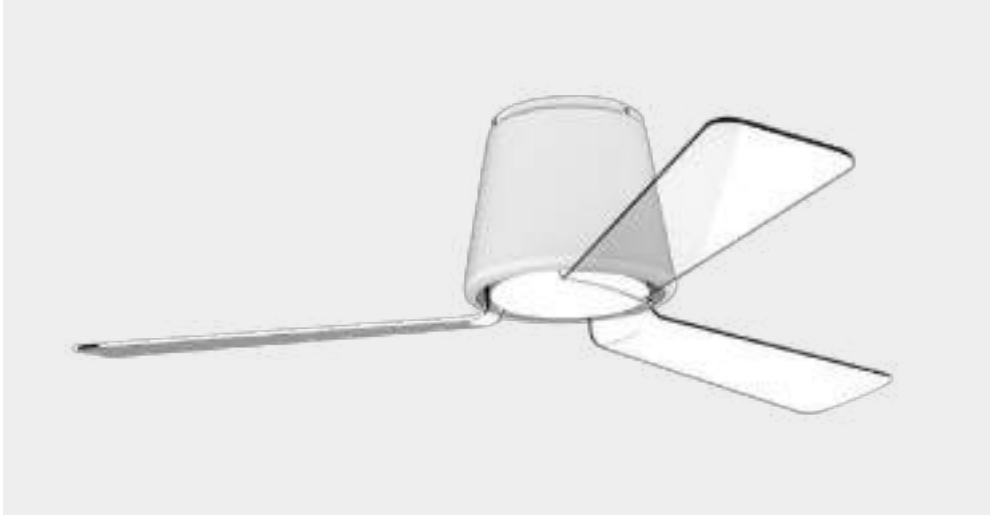

Garbí

QS

| | | | | | | | | | | |
|------------|--------------|------------|--|----|------------|---------|--|-------|--|--|
| BODY MAT | DIF MAT | BLADES MAT | | IP | AIRFLOW | | | DC | | |
| STEEL / AL | METHACRYLATE | ACRYLIC | | 44 | 175 m³/min | 20-32m² | | MOTOR | | |

Blanco Branco 14
 Transparente Transparente

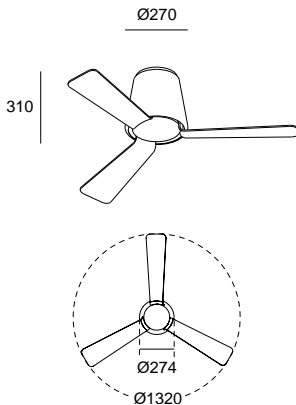

LED

| W | CRI | K | Real Lm | Source | Code | Structure | Blades |
|----|-----|------|---------|------------|--------------|-----------------------|----------------------------|
| 30 | | 3000 | 608 | 100-240VAC | 30-5378 - 14 | <input type="radio"/> | - F9 <input type="radio"/> |

| Speed | 1 | 2 | 3 | 4 | 5 | 6 |
|-------|-----|-----|-----|-----|---|-----|
| RPM | 110 | 138 | 165 | 193 | | 223 |



July

Essential Collection



July

QS

| | | | | | | | | | | | |
|------------|--------------|------------|--|------------|---------|--|--|-------|-----------------|--|--|
| BODY MAT | DIF MAT | BLADES MAT | | AIRFLOW | | | | DC | SWITCH CCT | | |
| STEEL / AL | METHACRYLATE | ABS | | 107 m³/min | 13-20m² | | | MOTOR | 3000/4000/5000K | | |

Blanco Branco NEG ●
Madera natural Madeira natural ●

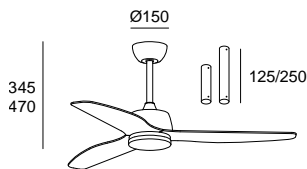

LED

| W | CRI | K | Real Lm | Source | Code | Structure | Blades | |
|------|-----|------|---------|----------|-----------------|-----------|--------|--------|
| | | 3000 | | | | | | |
| 47.5 | | 4000 | 2570 | 100-240V | VE-0020 - NEG ● | ● | | 266,80 |
| | | 5000 | | | | | | |

El flujo indicado por cada óptica corresponde al de 4000K de Temperatura de color.
The luminous flux indicated for each optic corresponds to that of a 4000K color temperature.

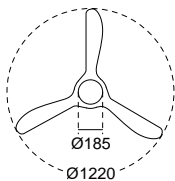

| Speed | 1 | 2 | 3 | 4 | 5 |
|-------|----|-----|-----|-----|---|
| RPM | 83 | 112 | 140 | 173 | |

QS Quick Service | 2-6 días laborables (tiempo de transporte no incluido)
Quick Service | 2-6 dias úteis (tempo de transporte não incluído)



Shadow

Performance Collection



Shadow

QS

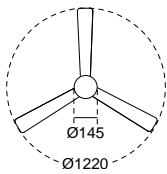
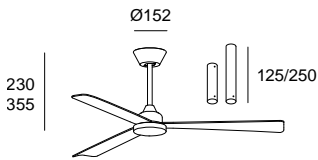
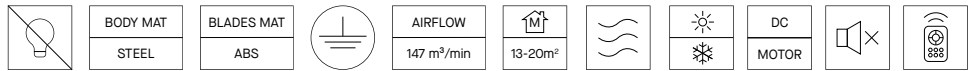

Negro Preto MAR ●
Nogal oscuro Nogueira escura ●

LED





| W | Source | Code | Structure | Blades |
|----|----------|-----------------|-----------|--------|
| 30 | 100-240V | VE-0093 - MAR ● | ● | ● |

| Speed | 1 | 2 | 3 | 4 | 5 | 6 |
|-------|-----|-----|-----|-----|---|-----|
| RPM | 103 | 128 | 150 | 167 | | 223 |

QS Quick Service | 2-6 días laborables (tiempo de transporte no incluido)
Quick Service | 2-6 dias úteis (tempo de transporte não incluído)

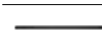
Accesorios

Acessórios

| | | | |
|--|--|------|---------------|
|  | 125mm / 250mm bar | | Included |
|  | 500mm bar | 05 ● | 71-B940-05-05 |
|  | Black wall controller for DC motor without light | 14 ○ | 71-C341-14-14 |
|  | White wall controller for DC motor without light | 05 ● | 71-C341-05-05 |



Designed by Jordi Blasi

Zonda

Performance Collection

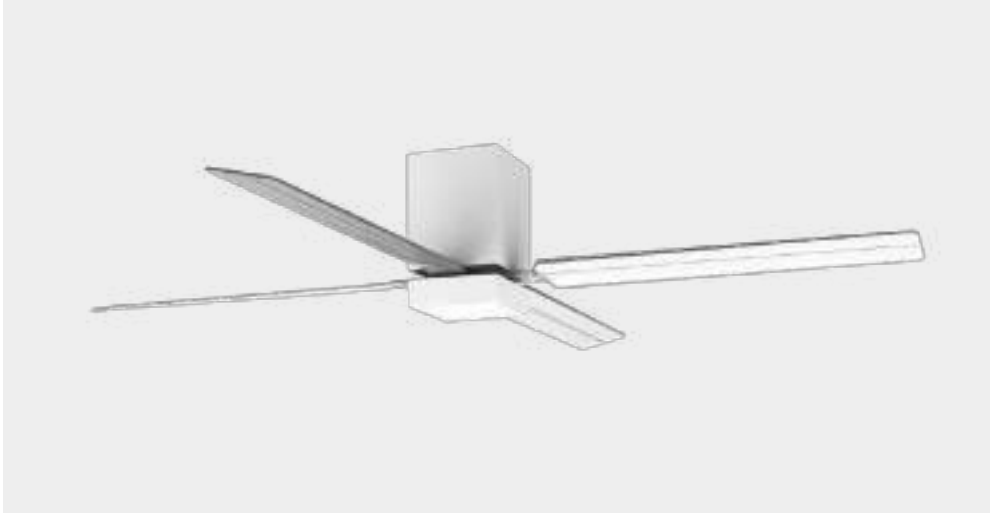

Zonda

QS

| | | | | | | | | | |
|-------------------|--------------------------|-----------------------------|--|-----------------------|-------------|--|-------------|--|--|
| BODY MAT STEEL | DIF MAT POLYCARBONATE | BLADES MAT POLYCARBONATE | | AIRFLOW 187 m³/min | 20-32m² | | DC MOTOR | | |
|-------------------|--------------------------|-----------------------------|--|-----------------------|-------------|--|-------------|--|--|

Blanco Branco 14
Transparente Transparente

LED

| W | CRI | K | Real Lm | Source | Code | Structure | Blades |
|----|-----|------|---------|------------|---|-----------------------|----------------------------|
| 51 | | 3000 | 2076 | 100-240VAC | 30-8548 - 14 <input type="radio"/> | <input type="radio"/> | - M1 <input type="radio"/> |

El flujo indicado por cada óptica corresponde al de 4000K de Temperatura de color.
The luminous flux indicated for each optic corresponds to that of a 4000K color temperature.

| Speed | 1 | 2 | 3 | 4 | 5 |
|-------|----|-----|-----|-----|---|
| RPM | 98 | 118 | 135 | 145 | |

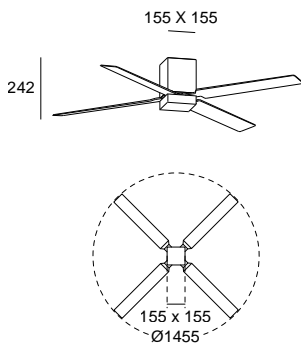



Smart lighting

Una iluminación inteligente tiene el poder de generar emociones y contribuir al bienestar de las personas. Transforma y moldea espacios, convirtiéndolos en entornos flexibles y dinámicos. Capta información relevante sobre la instalación, clave para mejorar su rentabilidad.

A iluminação inteligente tem o poder de evocar emoções e contribuir para o bem-estar das pessoas. Transforma e molda espaços, tornando-os ambientes flexíveis e dinâmicos. Além disso, capta informação relevante sobre a instalação, essencial para melhorar a sua rentabilidade.



Te ayudamos con tu idea

Nuestro equipo de especialistas de ayudará en la conceptualización de tu idea, ayudando a conseguir los hitos importantes para el proyecto, ya sean basados en el bienestar de las personas, en la flexibilidad de los espacios o bien en la eficiencia energética.

Ajudamos a concretizar a sua ideia

A nossa equipa de especialistas irá auxiliá-lo na conceção da sua ideia, ajudando-o a alcançar os marcos importantes do projeto, sejam eles relacionados com o bem-estar das pessoas, a flexibilidade dos espaços ou a eficiência energética.

Hacemos fácil lo difícil

Te acercamos la tecnología. Podemos integrar la tecnología en la propia luminaria premiando una instalación sencilla, o bien usando equipos de control centralizados que permiten maximizar las funcionalidades de control de iluminación.

Simplificamos o complexo

Levamos a tecnologia até si. Podemos integrar a tecnologia diretamente na luminária, dando prioridade à facilidade de instalação, ou utilizar sistemas de controlo centralizados que maximizam as funcionalidades de controlo da iluminação.



Lo hacemos realidad

Configuramos la iluminación para conseguir los hitos marcados inicialmente ya sean de eficiencia energética, escenas lumínicas o de captación de datos. Dependiendo del proyecto, ofrecemos la preconfiguración en fábrica de la iluminación o bien in situ.

Ajudamos a transformar a sua ideia em realidade

A nossa equipa de especialistas irá auxiliá-lo na conceção da sua ideia, ajudando a alcançar os principais objetivos do projeto, como o bem-estar das pessoas, a flexibilidade dos espaços e a eficiência energética.

Te acompañamos

Estamos presentes durante el ciclo de vida de tu instalación y te formamos para que le puedas sacar el máximo rendimiento tanto a nivel lumínico como digital gracias a los datos que se pueden extraer de los sistemas.

Simplificamos ou complicamos

Vamos levar a tecnologia ao extremo. Podemos integrar a tecnologia diretamente na luminária, dando prioridade à facilidade de instalação, ou utilizar sistemas de controlo centralizados que maximizem as funcionalidades de controlo da iluminação.



Beneficios de la iluminación inteligente

Benefícios da iluminação inteligente

Flexibilidad y bienestar

Una iluminación de calidad con control inteligente crea espacios saludables, confortables y flexibles, adaptados a cada actividad y a los ritmos de las personas.

Flexibilidade e bem-estar

Uma iluminação de qualidade com controlo inteligente cria espaços saudáveis, confortáveis e flexíveis, adaptados a cada atividade e aos ritmos das pessoas.

Eficiencia y ahorro energético

La integración de iluminación eficiente y control inteligente permite reducir el consumo energético mediante el uso óptimo de la ocupación, la luz natural y los recursos disponibles.

Eficiência e poupança energética

A integração de iluminação eficiente e controlo inteligente permite reduzir o consumo energético através da utilização otimizada da ocupação, da luz natural e dos recursos disponíveis.

Color y emociones

El control avanzado de LedsC4 transforma el color en una herramienta emocional y comunicativa, capaz de gestionar miles de luminarias y universos DMX para crear experiencias luminicas dinámicas, coherentes y adaptadas a cada contexto.

Cor e emoções

Os sistemas avançados de controlo da LedsC4 transformam a cor numa ferramenta emocional e comunicativa, capaz de gerir milhares de luminárias e universos DMX para criar experiências luminosas dinâmicas, coerentes e adaptadas a cada contexto.

Servicios LedsC4

Ofrecemos acompañamiento integral en todas las fases del proyecto, desde el asesoramiento inicial y la documentación técnica hasta la ejecución en obra, asegurando que cada idea se haga realidad.

Serviços LedsC4

Oferecemos um acompanhamento completo em todas as fases do projeto, desde o aconselhamento inicial e documentação técnica até à execução em obra, garantindo que cada ideia se concretiza.



Mantenimiento y uso de espacios

Los sistemas de control de LedsC4 convierten la iluminación en un subsistema estratégico, aportando datos de uso y estado que optimizan la eficiencia, la circularidad y el aprovechamiento inteligente de los espacios.

Sostenibilidad y circularidad

La monitorización avanzada permite ajustar el consumo energético a las necesidades reales, optimizar el mantenimiento y alargar la vida útil de las luminarias, fomentando la circularidad y una gestión sostenible de los recursos.

Créditos de certificaciones

La tecnología de LedsC4 facilita la obtención de créditos en certificaciones de edificios como LEED, BREEAM y WELL, ya que gracias al control inteligente de iluminación se puede mejorar el bienestar de las personas, el rendimiento energético y el aprovechamiento de los recursos.

Extensión de garantía LedsC4

Accede a una extensión de garantía de los productos de LedsC4 al aplicar sistemas de gestión inteligente de la iluminación que permitan: la gestión horaria de los encendidos, control de las intensidades lumínicas y gestión automática mediante el uso de sensores de presencia y/o luminosidad.

Manutenção e utilização dos espaços

Os sistemas de controlo da LedsC4 transformam a iluminação num subsistema estratégico, fornecendo dados de utilização e estado que otimizam a eficiência, a circularidade e o uso inteligente dos espaços.

Sustentabilidade e circularidade

A monitorização avançada permite ajustar o consumo energético às necessidades reais, otimizar a manutenção e prolongar a vida útil das luminárias, promovendo uma gestão sustentável dos recursos.

Créditos de certificação

A tecnologia da LedsC4 facilita a obtenção de créditos em certificações de edifícios como LEED, BREEAM e WELL, melhorando o bem-estar das pessoas, o desempenho energético e a utilização dos recursos.

Extensão de garantia LedsC4

Aceda a uma extensão de garantia dos produtos LedsC4 através da implementação de sistemas inteligentes de gestão da iluminação que permitem a programação horária, o controlo dos níveis luminosos e a gestão automática com sensores de presença e/ou luminosidade.

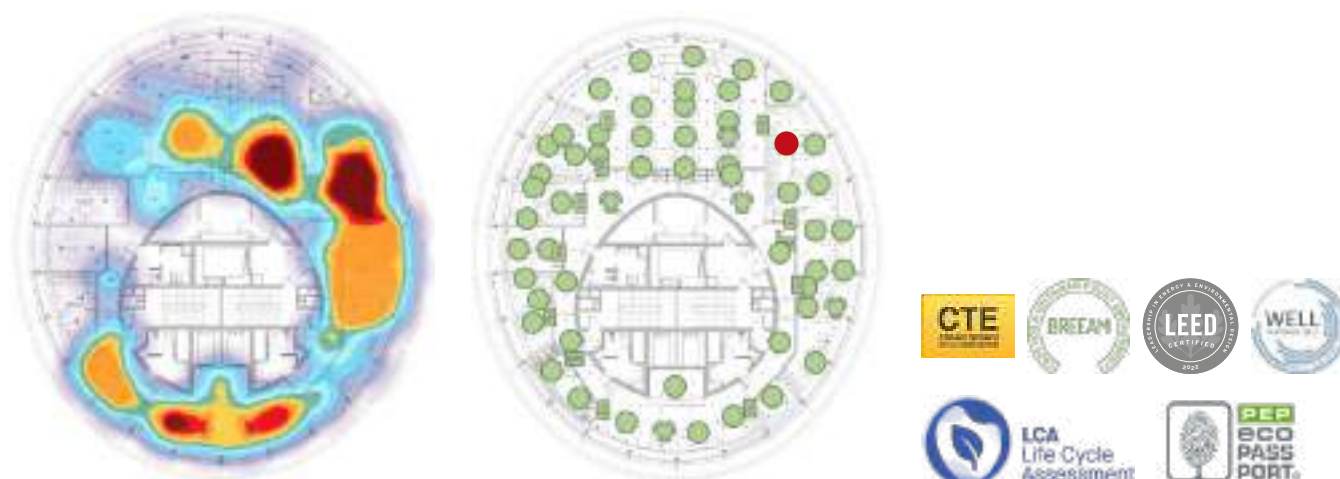

DALI2

Solución para el control y la conectividad basada en el estándar DALI2.

Solução para o controlo e conectividade da Solução de controlo de iluminação baseada no standard DALI2.

Funcionalidades

Permite conseguir, en una instalación, un gran ahorro energético mediante funcionalidades como gestión de luminarias punto a punto, grupos, escenas, control de luz constante, ciclo circadiano, control por ocupación y programaciones horarias, entre otras.

Permite conseguir, numa instalação, uma grande poupança energética mediante funcionalidades como gestão de luminárias ponto a ponto, grupos, cenas, controlo de luz constante, ciclo circadiano, controlo por ocupação e programações horárias, entre outras.



Parking BSM, Barcelona 2024.

Elige la opción más adecuada a tu proyecto Escolha a opção mais adequada ao seu projeto

① 71-B102

② 71-B103

③ 71-B849

①



②

③

- Calendario, grupos, escenas, sensores de presencia y luminosidad
Calendário, grupos, cenas, sensores de presença e luminosidade
- Ciclo circadiano y luminarias Tunnable White
Ciclo circadiano e luminárias Tunnable White
- Compatible con licencia para luminarias de emergencia
Compatível com licença para luminárias de emergência
- Compatible con licencia BACnet
Compatível com licença BACnet
- Sistema sin límite de controladores
Sistema sem limite de número de controladores
- Sistema compatible con servicios cloud para gestión del consumo y uso del espacio
Sistema compatível com serviços em nuvem para a gestão de consumo e utilização do espaço





Dispositivos de control DALI

Dispositivos de controlo DALI

| | | |
|---|---|----------------------|
|  | <p>Controlador DALI2 Essential, hasta 192 dispositivos DALI2, permite control de escenas de iluminación y grupos, configuraciones horarias y de calendario, sensores de luminosidad y presencia, botoneras multifunción DALI2. Control Bacnet disponible bajo licencia. Instalación a carril DIN. Control de luminarias de emergencia DALI 2 disponible bajo licencia. 110-240V</p> <p>Controlador DALI2 Essential, até 192 dispositivos DALI2, permite o controlo de cenas de iluminação e grupos, configurações horárias e de calendário, sensores de luminosidade e presença, botoneiras multifunção DALI2. Controlo Bacnet disponível sob licença. Instalação em calha DIN. Controlo de luminárias de emergência DALI 2 disponível sob licença. 110-240V</p> | 71-B102-00-00 |
|  | <p>Controlador DALI2 Performance, hasta 192 dispositivos DALI2, permite control de escenas de iluminación y grupos, configuraciones horarias y de calendario, sensores de luminosidad y presencia, botoneras multifunción DALI2. Incorpora la posibilidad de control de luminarias Tunnable White y Ciclo circadiano. Instalación a carril DIN. Control Bacnet disponible bajo licencia. 110-240V</p> <p>Controlador DALI2 Performance, até 192 dispositivos DALI2, permite o controlo de cenas de iluminação e grupos, configurações horárias e de calendário, sensores de luminosidade e presença, botoneiras multifunção DALI2. Incorpora a possibilidade de controlo de luminárias Tunnable White e Ciclo circadiano. Instalação em calha DIN. Controlo Bacnet disponível sob licença. 110-240V</p> | 71-B103-00-00 |
|  | <p>Controlador DALI 2 Advance, hasta 256 luminarias DALI2 y 254 dispositivos de control DALI2 (sensores o botoneras), permite control de escenas de iluminación y grupos, configuraciones horarias y de calendario, sensores de luminosidad y presencia, botoneras multifunción DALI2. Incorpora la posibilidad de control de luminarias Tunnable White y Ciclo circadiano. Instalación a carril DIN. 220-240V</p> <p>Controlador DALI 2 Advance, até 256 luminárias DALI2 e 254 dispositivos de controlo DALI2 (sensores ou botoneiras), permite o controlo de cenas de iluminação e grupos, configurações horárias e de calendário, sensores de luminosidade e presença, botoneiras multifunção DALI2. Incorpora a possibilidade de controlo de luminárias Tunnable White e Ciclo circadiano. Instalação em calha DIN. 220-240V</p> | 71-B849-00-00 |

Pantallas de control

Ecrãs de controlo

| | | |
|---|---|----------------------|
|  | <p>Pantalla controlador DALI2 7" Blanca, hasta 64 dispositivos DALI2 ampliable a 256 con la referencia 71-C012-00-00, permite control de escenas de iluminación y grupos, configuraciones horarias y de calendario, sensores de luminosidad y presencia, botoneras multifunción DALI2. Permite visualización calidad del aire. 24V o PoE.</p> <p>Ecrã do controlador DALI2 de 7" Branco, até 64 dispositivos DALI2, ampliável até 256 com a referência 71-C012-00-00, permite o controlo de cenas de iluminação e grupos, configurações horárias e de calendário, sensores de luminosidade e presença, botoneiras multifunção DALI2. Permite a visualização da qualidade do ar. 24V ou PoE.</p> | 71-B909-14-14 |
|  | <p>Pantalla controlador DALI2 7" Negra, hasta 64 dispositivos DALI2 ampliable a 256 con la referencia 71-C012-00-00, permite control de escenas de iluminación y grupos, configuraciones horarias y de calendario, sensores de luminosidad y presencia, botoneras multifunción DALI2. Permite visualización calidad del aire. 24V o PoE.</p> <p>Ecrã do controlador DALI2 de 7" Preto, até 64 dispositivos DALI2, ampliável até 256 com a referência 71-C012-00-00, permite o controlo de cenas de iluminação e grupos, configurações horárias e de calendário, sensores de luminosidade e presença, botoneiras multifunção DALI2. Permite a visualização da qualidade do ar. 24V ou PoE.</p> | 71-B909-60-60 |
|  | <p>Pantalla controlador DALI2 4" Blanca, hasta 64 dispositivos DALI2, permite control de escenas de iluminación y grupos, sensores de luminosidad y presencia, botoneras multifunción DALI2. Permite visualización Calidad del Aire. 24V o PoE.</p> <p>Ecrã do controlador DALI2 de 4" Branco, até 64 dispositivos DALI2, permite o controlo de cenas de iluminação e grupos, sensores de luminosidade e presença, botoneiras multifunção DALI2. Permite a visualização da qualidade do ar. 24V ou PoE.</p> | 71-B908-14-14 |
|  | <p>Pantalla controlador DALI2 4" Negra, hasta 64 dispositivos DALI2, permite control de escenas de iluminación y grupos, sensores de luminosidad y presencia, botoneras multifunción DALI2. Permite visualización Calidad del Aire. 24V o PoE.</p> <p>Ecrã do controlador DALI2 4" Preto, até 64 dispositivos DALI2, permite o controlo de cenas de iluminação e grupos, sensores de luminosidade e presença, botoneiras multifunção DALI2. Permite a visualização da qualidade do ar. 24V ou PoE.</p> | 71-B908-60-60 |
|  | <p>Extensión 3 buses DALI2 para pantalla 7", permite controlar hasta 192 dispositivos DALI2. 24VDC. 90mA + PoE.</p> <p>Extensão 3 buses DALI2 para ecrã de 7", permite controlar até 192 dispositivos DALI2. 24VDC. 90mA + PoE</p> | 71-C012-00-00 |

Fuentes de alimentación

Fontes de alimentação

| | | |
|---|--|----------------------|
|  | Fuente de alimentación 24Vdc DALI2 para tiras de LED o luminarias regulables PWM, 1 canal de 60W. 100-230V Fonte de alimentação 24Vdc DALI2 para fitas LED ou luminárias reguláveis PWM, 1 canal de 60W. 100-230V | 71-E098-00-00 |
|  | Fuente de alimentación 24Vdc DALI2 para tiras de LED o luminarias regulables PWM, 1 canal de 120W. 100-230V Fonte de alimentação 24Vdc DALI2 para fitas LED ou luminárias reguláveis PWM, 1 canal de 120W. 100-230V | 71-E099-00-00 |
|  | Fuente de alimentación 24Vdc DALI2 Dt8 para tiras de LED tunnable white, 2 canales. 160W. 230V Fonte de alimentação 24Vdc DALI2 Dt8 para fitas LED tunnable white, 2 canais. 160W. 230V | 71-B401-00-00 |
|  | Fuente de alimentación 24Vdc. 4 canales independientes, control DALI-2(DT6/DT8), DMX512/RDM. Máximo 150W. 220-240Vac. Fonte de alimentação 24Vdc. 4 canais independentes, controlo DALI-2(DT6/DT8), DMX512/RDM. Máximo 150W. 220-240Vac." | 71-C277-00-00 |
|  | Fuente con salida 24V y 130mA. 230V Fonte com saída de 24V e 130mA. 230V | 71-C013-00-00 |
|  | Fuente para 1 bus DALI2 a carril DIN. 120-240V Fonte para 1 bus DALI2 em calha DIN. 120-240V | 71-C014-00-00 |
|  | Fuente de alimentación para Displays. IP20, 24Vdc, 300mA. Montaje a carril DIN. Fonte de alimentação para displays. IP20, 24Vdc, 300mA. Montagem em calha DIN. | 71-C278-00-00 |





Rele

Relé

| | | |
|---|--|----------------------|
|  | Rele On Off DALI2 para luminarias LED, hasta 1380W, 6A. 230V Relé On Off DALI2 para luminárias LED, até 1380W, 6A. 230V | 71-B101-00-00 |
|---|--|----------------------|

Sensores

Sensores

| | | |
|---|--|----------------------|
|  | Sensor de luminosidad y movimiento para instalación de empotrar DALI2. Diámetro detección 5m a altura 3m. De 0,5 – 2.000 lx de luminosidad. Alimentación directa bus DALI 9mA. Sensor de luminosidade e movimento para instalação de encastrar DALI2. Diâmetro de deteção 5 m e 3 m de altura. De 0,5 – 2.000 lx de luminosidade. Alimentação direta bus DALI 9mA. | 71-B098-00-00 |
|  | Sensor de luminosidad y movimiento para instalación de superficie DALI2. Diámetro detección 5m a altura 3m. De 0,5 – 2.000 lx de luminosidad. Alimentación directa bus DALI 9mA. Sensor de luminosidade e movimento para instalação de superfície DALI2. Diâmetro de deteção 5 m e 3 m de altura. De 0,5 – 2.000 lx de luminosidade. Alimentação direta bus DALI 9mA. | 71-B100-00-00 |
|  | Sensor DALI 2 para detección de movimiento. Diámetro detección 8m a altura de 3m. Alimentación directa del bus DALI consumo 10mA. Sensor DALI 2 para deteção de movimento. Diâmetro de deteção 8 m e 3 m de altura. Alimentação direta do bus DALI consumo 10mA. | 71-B876-00-00 |
|  | Accesorio superficie Sensor 71-B876-00-00 Acessório superfície Sensor 71-B876-00-00 | 71-B877-00-00 |
|  | Multisensor luminosidad y presencia empotrar DALI2 advance. diametro de detección 8m. Alimentación directa bus DALI consumo 10mA. Multissensor luminosidade e presença de encastrar DALI2 advance. Diâmetro de deteção 8 m. Alimentação direta bus DALI consumo 10mA. | 71-B850-00-00 |

Botoneras

Botoneiras

| | | |
|--|--|----------------------|
| | <p>Conversor de señales libre de potencial, apto para incorporar pulsadores convencionales al entorno DALI2. Alimentación directa bus DALI 10mA.</p> <p>Conversor de sinais sem potencial, adequado para incorporar botões convencionais no ambiente DALI2. Alimentação direta do bus DALI 10mA.</p> | 71-B099-00-00 |
| | <p>Botonera 4 funciones acabado Negro DALI2. Alimentación directa bus DALI 10mA.</p> <p>Botoneira de 4 funções, acabamento Preto DALI2. Alimentação direta do bus DALI 10mA.</p> | 71-B756-60-60 |
| | <p>Botonera 4 funciones acabado Blanco DALI2. Alimentación directa bus DALI 10mA.</p> <p>Botoneira de 4 funções, acabamento Branco DALI2. Alimentação direta do bus DALI 10mA.</p> | 71-B756-14-14 |

Licencias

Licenças

| | | |
|--|---|----------------------|
| | <p>Licencia Bacnet 100 Variables para controlador 71-B102-00-00 o 71-B103-00-00</p> <p>Licença Bacnet 100 Variáveis para o controlador 71-B102-00-00 ou 71-B103-00-00</p> | 71-B830-00-00 |
| | <p>Licencia Bacnet 1000 Variables para controlador 71-B102-00-00 o 71-B103-00-00</p> <p>Licença Bacnet 1000 Variáveis para o controlador 71-B102-00-00 ou 71-B103-00-00</p> | 71-B831-00-00 |
| | <p>Licencia DALI2 Emergencia 100 luminarias 71-B102-00-00 o 71-B103-00-00</p> <p>Licença DALI2 Emergência 100 luminárias 71-B102-00-00 ou 71-B103-00-00</p> | 71-B117-00-00 |

Bluetooth Casambi

Solución de control de iluminación basada en el protocolo Bluetooth Mesh con control directo desde Smartphone o Tablet, sin necesidad de añadir ningún elemento adicional. La facilidad de uso del sistema permite que sea válida para cualquier usuario. Su aplicación es ideal para entornos flexibles y dinámicos, donde se requiera una gran interacción con las luminarias.

Solução de controlo de iluminação baseada no protocolo Bluetooth Mesh com controlo direto desde Smartphone ou Tablet, sem necessidade de adicionar nenhum elemento adicional. A facilidade de uso do sistema permite que seja válida para qualquer utilizador. A sua aplicação é ideal para ambientes flexíveis e dinâmicos, onde seja necessária uma grande interação com as luminárias.



Brondesbury Park Synagogue, London 2022.



Funcionalidades Funcionalidades













- Control individual de las luminarias y regulación punto a punto
Controlo individual das luminárias e regulação ponto a ponto
- Creación de grupos de luminarias
Criação de grupos de luminárias
- Regulación según calendario
Regulação segundo calendário
- Control de la temperatura de color
Controlo da temperatura de cor
- Ciclo circadiano
Ciclo circadiano
- Regulación según nivel de luz natural
Regulação segundo o nível de luz natural

Dispositivos Bluetooth Casambi

Dispositivos Bluetooth Casambi

Controladores / conversores

Controladores / conversores











| | | |
|---|---|----------------------|
|  | <p>Convertor Casambi para productos regulables corte de fase <i>trailing edge</i>. Máximo 144W, Máximo inrush current 10A. 85-240Vac.</p> <p>Convertor Casambi para produtos reguláveis com corte de fase <i>trailing edge</i>. Máximo 144W, Máximo inrush current 10A. 85-240Vac.</p> | 71-5959-00-00 |
|  | <p>Convertor Casambi para productos regulables 0-10V o DALI. Hasta 2 drivers DALI, o 1 driver 0-10V. 230Vac.</p> <p>Convertor Casambi para produtos reguláveis 0-10V ou DALI. Até 2 drivers DALI, ou 1 driver 0-10V. 230Vac.</p> | 71-5961-00-00 |
|  | <p>Convertor Casambi para productos regulables 0-10V o DALI. Hasta 1 driver DALI o 2 drivers 0-10V. 100-240Vac.</p> <p>Convertor Casambi para produtos reguláveis 0-10V ou DALI. Até 1 driver DALI ou 2 drivers 0-10V. 100-240Vac.</p> | 71-B669-00-00 |
|  | <p>Convertor Casambi a DALI, hasta 50 luminarias. Permite controlarlas simultáneamente o hasta en 8 grupos si se realiza un direccionamiento DALI adicional. 100-240Vac.</p> <p>Convertor Casambi para DALI, até 50 luminárias. Permite serem controladas simultaneamente ou até em 8 grupos, se for realizado um direccionamento DALI adicional. 100-240Vac.</p> | 71-B855-00-00 |
|  | <p>Relé Casambi, para cargas LED de máximo 1500W. 100-240Vac.</p> <p>Relé Casambi, para cargas LED de 1500W máximo. 100-240Vac.</p> | 71-A300-00-00 |
|  | <p>Convertor pasivo Casambi integrar sensores DALI o para controlar drivers DALI con fuente integrada.</p> <p>Convertor passivo Casambi para integrar sensores DALI ou para controlar drivers DALI com fonte integrada.</p> | 71-8051-00-00 |
|  | <p>Convertor Casambi a DALI Broadcast IP66. 100-240Vac.</p> <p>Convertor Casambi para DALI Broadcast IP66. 100-240Vac.</p> | 71-A237-00-00 |
|  | <p>Convertor Casambi a DMX Broadcast IP66. 100-240Vac.</p> <p>Convertor Casambi para DMX Broadcast IP66. 100-240Vac.</p> | 71-A238-00-00 |
|  | <p>Convertor Casambi a DALI para sistemas de carril "low voltage". Hasta 64 dispositivos DALI. Permite controlarlas simultáneamente "broadcast" o hasta en 8 grupos si se realiza direccionamiento DALI adicional. 48V</p> <p>Convertor Casambi para DALI para sistemas de calha "low voltage". Até 64 dispositivos DALI. Permite serem controlados simultaneamente "broadcast" ou até em 8 grupos, se for realizado um direccionamento DALI adicional. 48V</p> | 71-8115-00-00 |
|  | <p>Convertor Casambi a DALI acabado blanco para sistemas de carril trifásicos. Hasta 64 dispositivos. Permite controlarlas simultáneamente "Broadcast". 100-240Vac.</p> <p>Convertor Casambi para DALI, acabamento branco para sistemas de calha trifásica. Até 64 dispositivos. Permite serem controlados simultaneamente "Broadcast". 100-240Vac.</p> | 71-A243-14-14 |
|  | <p>Convertor Casambi a DALI acabado negro para sistemas de carril trifásicos. Hasta 64 dispositivos. Permite controlarlas simultáneamente "Broadcast". 100-240Vac.</p> <p>Convertor Casambi para DALI, acabamento preto para sistemas de calha trifásica. Até 64 dispositivos. Permite serem controlados simultaneamente "Broadcast". 100-240Vac.</p> | 71-A243-60-60 |
|  | <p>Convertor Casambi a DALI acabado blanco para sistemas DALI. Permite controlar hasta 16 dispositivos. Permite controlarlas individualmente. Requiere fuente de alimentación externa para el bus DALI.</p> <p>Convertor Casambi para DALI acabamento branco para sistemas DALI. Permite controlar até 16 dispositivos. Permite controlá-los individualmente. Requer fonte de alimentação externa para o barramento DALI.</p> | 71-C274-00-00 |
|  | <p>Convertor Casambi a DALI acabado blanco para sistemas DALI. Permite controlar hasta 32 dispositivos. Permite controlarlas individualmente. Requiere fuente de alimentación externa para el bus DALI.</p> <p>Convertor Casambi para DALI acabamento branco para sistemas DALI. Permite controlar até 32 dispositivos. Permite controlá-los individualmente. Requer fonte de alimentação externa para o barramento DALI.</p> | 71-C275-00-00 |

Dispositivos Bluetooth Casambi

Dispositivos Bluetooth Casambi





Controladores Bajo voltaje

Controladores Baixa tensão

| | | |
|---|---|----------------------|
|  | Regulador Casambi para tiras LED y productos a tensión constante 12-24Vdc. 1 canal. Dispone de entrada pulsador. Máximo 10A. Requiere fuente de alimentación. Regulador Casambi para fitas LED e produtos de tensão constante 12-24Vdc. 1 canal. Possui uma entrada de botão. Máximo 10A. Necessário fonte de alimentação. | 71-A857-00-00 |
|  | Fuente Casambi IP20 para tiras LED y productos a tensión constante 24Vdc. 1 canal. Máximo 60W. 220-240V Fonte Casambi IP20 para fitas LED e produtos de tensão constante 24Vdc. 1 canal. Máximo 60W. 220-240V | 71-B864-00-00 |
|  | Fuente Casambi IP20 para tiras LED y productos a tensión constante 24Vdc. 1 canal. Máximo 100W. 220-240V Fonte Casambi IP20 para fitas LED e produtos de tensão constante 24Vdc. 1 canal. Máximo 100W. 220-240V | 71-B865-00-00 |
|  | Fuente Casambi IP20 para tiras LED y productos a tensión constante 24Vdc. 1 canal. Máximo 150W. 220-240V Fonte Casambi IP20 para fitas LED e produtos de tensão constante 24Vdc. 1 canal. Máximo 150W. 220-240V | 71-B866-00-00 |
|  | Fuente Casambi IP67 para tiras LED y productos a tensión constante 24Vdc. 1 canal. Máximo 60W. 90-305Vac. Fonte Casambi IP67 para fitas LED e produtos de tensão constante 24Vdc. 1 canal. Máximo 60W. 90-305Vac. | 71-B670-00-00 |
|  | Fuente Casambi IP67 para tiras LED y productos a tensión constante 24Vdc. 1 canal. Máximo 120W. 90-305Vac. Fonte Casambi IP67 para fitas LED e produtos de tensão constante 24Vdc. 1 canal. Máximo 120W. 90-305Vac. | 71-A242-00-00 |
|  | Fuente Casambi IP67 para tiras LED y productos a tensión constante 24Vdc. 1 canal. Máximo 200W. 90-305Vac. Fonte Casambi IP67 para fitas LED e produtos de tensão constante 24Vdc. 1 canal. Máximo 200W. 90-305Vac. | 71-B671-00-00 |
|  | Regulador Casambi para tiras LED y productos a tensión constante 12-24Vdc. 4 canales. Máximo 144W. Requiere fuente de alimentación. Apto para productos tunable white, RGB y RGBW. Regulador Casambi para fitas LED e produtos de tensão constante 12-24Vdc. 4 canais. Máximo 144W. Necessário fonte de alimentação. Adequado para produtos tunable white, RGB e RGBW. | 71-8050-00-00 |
|  | Caja IP con regulador Casambi para tiras LED y productos a tensión constante 12-24Vdc. 4 canales. Máximo 144W. Apto para productos tunable white, RGB y RGBW. 90-295Vac. Caixa IP com regulador Casambi para fitas LED e produtos de tensão constante 12-24Vdc. 4 canais. Máximo 144W. Adequado para produtos tunable white, RGB e RGBW. 90-295Vac. | 71-E300-00-00 |
|  | Regulador Casambi para tiras LED y productos a tensión constante 12-24Vd. 4 canales 4x5A. Máximo 10A. Requiere fuente de alimentación. Apto para productos tunable white, RGB y RGBW. Regulador Casambi para fitas LED e produtos de tensão constante 12-24Vd. 4 canais 4x5A. Máximo 10A. Necessário fonte de alimentação. Adequado para produtos tunable white, RGB e RGBW. | 71-B672-00-00 |

Botoneras

Botoneiras





| | | |
|---|---|----------------------|
|  | Botonera 4 funciones acabado Antracita Enocean. Botoneira de 4 funções com acabamento Antracite Enocean. | 71-B673-00-00 |
|  | Botonera 4 funciones acabado Blanco Enocean. Botoneira de 4 funções com acabamento Branco Enocean. | 71-B674-00-00 |
|  | Botonera Casambi 4 funciones más regulación acabado negro. Batería CR2430. Botoneira Casambi de 4 funções mais regulação com acabamento preto. Batería CR2430. | 71-8053-00-00 |
|  | Botonera Casambi 4 funciones más regulación acabado blanco. Batería CR2430. Botoneira Casambi de 4 funções mais regulação com acabamento branco. Batería CR2430. | 71-A240-00-00 |
|  | Botonera 1 función acabado Blanco Enocean. Botoneira de 1 função com acabamento Branco Enocean. | 71-B113-00-00 |

Dispositivos Bluetooth Casambi

Dispositivos Bluetooth Casambi





Sensores

Sensores

| | | |
|---|--|----------------------|
|  | Accesorio para instalación en superficie del sensor 71-8049-00-00 Acessório para instalação na superfície do sensor 71-8049-00-00 | 71-B743-00-00 |
|  | Sensor de presencia y luminosidad Casambi. IP40. Diámetro detección 6m a altura 3m. De 1 – 2.000 lx de luminosidad. 230V Sensor de presença e luminosidade Casambi. IP40. Diâmetro de deteção 6 m e 3 m de altura. De 1 – 2.000 lx de luminosidade. 230V | 71-8049-00-00 |
|  | Sensor de presencia y luminosidad Casambi con salida DALI incorporada de hasta 10 luminarias. Diámetro detección 5,6m a altura 3m. De 1 – 999 lx de luminosidad IP40. 230V Sensor de presença e luminosidade Casambi com saída DALI incorporada de até 10 luminárias. Diâmetro de deteção 5,6 m e 3 m de altura. De 1 – 999 lx de luminosidade IP40. 230V | 71-A696-00-00 |
|  | Sensor de presencia y luminosidad Casambi a carril trifásico, acabado negro. Diámetro detección 3,75m a altura 3m. 230V Sensor de presença e luminosidade Casambi para calha trifásica, acabamento preto. Diâmetro de deteção 3,75 m e 3 m de altura. 230V | 71-A241-60-60 |
|  | Sensor de presencia y luminosidad Casambi a carril trifásico, acabado blanco. Diámetro detección 3,75m a altura 3m. 230V Sensor de presença e luminosidade Casambi para calha trifásica, acabamento branco. Diâmetro de deteção 3,75 m e 3 m de altura. 230V | 71-A241-14-14 |

Adicionales

Adicionais

| | | |
|---|--|----------------------|
|  | Router Gateway Wifi para conexión a cloud Casambi de la red. Apto para dotar de acceso remoto a la red y asegurar funcionamiento de las programaciones horarias y de calendario. 5V DC via USB-C (3A) o PoE. Router Gateway Wi-fi para ligação à cloud Casambi na rede. Adequado para fornecer acesso remoto à rede e assegurar o funcionamento das programações horárias e calendário. 5V DC via USB-C (3A) ou PoE. | 71-B750-00-00 |
|  | Timer Casambi para garantizar el funcionamiento de las programaciones horarias. Timer Casambi para garantir o funcionamento das programações horárias. | 71-8052-00-00 |
|  | Caja estanca con dos prensaestopas M20 para entrada y salida y protección IP66 (IP68 no permanente). Almacenaje para los controladores Casambi 71- 5961-00-00, 71-B855-00-00, 71-A300-00-00. Tensión máxima 400Vac. Aislamiento 2500Vac. Material PA66 con tratamiento anti-UV. Resistencia al fuego UL94 V-0. Caixa estanque com duas prensa-cabos M20 para entrada e saída e proteção IP66 (IP68 não permanente). Armazenamento para os controladores Casambi 71-5961-00-00, 71-B855-00-00, 71-A300-00-00. Tensão máxima 400Vac. Isolamento 2500Vac. Material PA66 com tratamento anti-UV. Resistência ao fogo UL94 V-0. | 71-C351-00-00 |
|  | Repetidor Casambi con alcance máximo de 150m. Protección IP20. Carcasa de policarbonato blanco. Repetidor Casambi com alcance máximo de 150m. Proteção IP20. Caixa de policarbonato branco. | 71-C352-00-00 |

DMX

Sistema de control DMX que permite una gestión de la iluminación dinámica con unas transiciones de color a alta velocidad, permitiendo incluso un posible control punto a punto de cada luminaria.

Sistema de controlo DMX que permite a gestão dinâmica da iluminação com transições de cor de alta velocidade, permitindo inclusive o controlo ponto a ponto de cada luminária.

Funcionalidades



Puente de los Remedios, Villafranca de Cordoba 2022

Elige la opción más adecuada a tu proyecto
Escolha a opção mais adequada ao seu projeto

- ① 71-B115
- ② 71-B116
- ③ 71-B667
- ④ 71-C271

①

②

③

④

- Control Luminarias DMX RGB o RGBW
Controlo Luminárias DMX RGB ou RGBW
- 1 universo DMX-RDM 512
1 universo DMX-RDM 512
- Wifi
- 36 Escenas
36 Cenas
- Programaciones horarias y calendario
Programações horárias e calendário
- Programación por APP
Programação por APP
- 2 universos DMX-RDM 1024
2 universos DMX-RDM 1024
- Hasta 500 escenas
Até 500 cenas
- Ethernet
- Acceso remoto
Acesso remoto
- Gestión de contenidos / Luminarias pixel
Gestão de conteúdos / Luminárias pixel

Controladores de pared DMX

 Pantalla táctil DMX básica no programable. Controla simultáneamente "Broadcast" luminarias DMX. Permite guardar 4 colores. Instalacion en caja universal de mecanismos de 65x65. 100-240V
Ecrã tátil DMX básico, não programável. Controla simultaneamente "Broadcast" luminárias DMX. Permite guardar 4 cores. Instalação numa caixa universal de derivação de 65x65. 100-240V

71-7666-00-00



Consola táctil DMX RDM programable. 512 canales DMX. WiFi. 36 escenas, 1 zona. Control horario y por calendario. Requiere conocimientos de programación DMX, no permite acceso remoto.
Consola tátil DMX RDM programável. 512 canais DMX. Wi-fi. 36 cenas, 1 zona. Controlo horário e por calendário. Requer conhecimentos de programação DMX, não permite o acesso remoto.

71-B115-00-00



Consola táctil DMX RDM programable. 1024 canales DMX. Puerto ethernet. 500 escenas, 10 zonas. microSD. Control horario y por calendario. Requiere conocimientos de programación DMX. No permite acceso remoto.
Consola tátil DMX RDM programável. 1024 canais DMX. Porta Ethernet. 500 cenas, 10 zonas. microSD. Controlo horário e por calendário. Requer conhecimentos de programação DMX. Não permite o acesso remoto.

71-B116-00-00



Divisores de señal

Divisores de sinal

| | | |
|---|--|----------------------|
|  | Derivador y amplificador DMX RDM. 4 canales. Instalación a carril DIN. Requiere fuente de alimentación 12Vdc. Derivador e amplificador DMX RDM. 4 canais. Instalação em calha DIN. Necessário fonte de alimentação 12Vdc. | 71-B125-00-00 |
|  | Derivador y amplificador DMX RDM. 10 canales. Instalación en Rack. 100-240Vac. Derivador e amplificador DMX RDM. 10 canais. Instalação em Rack. 100-240Vac. | 71-B668-00-00 |
|  | Fuente de alimentación salida 12Vdc. 230Vac. Fonte de alimentação saída 12Vdc. 230Vac. | 71-B416-00-00 |



Reguladores

Reguladores

| | | |
|---|--|----------------------|
|  | Controlador DMX-RDM PWM para tiras LED y producto a tensión constante 12-24V, 5 canales de 8A. Requiere fuente de alimentación. Puertos RJ45, XLR y de tornillo. Dispone de modo esclavo DMX o de modo master para funcionamiento autónomo. Controlador DMX-RDM PWM para fitas LED e produtos com tensão constante 12-24V, 5 canais de 8A. Necessário fonte de alimentação. Portas RJ45, XLR e de parafuso. Possui modo escravo DMX ou modo master para funcionamento autónomo. | 71-B755-00-00 |
|  | Fuente de alimentación 24Vdc. 4 canales independientes, control DALI-2 (DT6/DT8), DMX512/RDM. Máximo 150W. 220-240Vac. Fonte de alimentação 24Vdc. 4 canais independentes, controlo DALI-2(DT6/DT8), DMX512/RDM. Máximo 150W. 220-240Vac" | 71-C277-00-00 |
|  | Convertor DMX RDM a SPI para control de tiras LED pixel SPI. 128 canales. Convertor DMX RDM para SPI para controlo de fitas LED com pixel SPI. 128 canais. | 71-B853-00-00 |



Controlador con posibilidad de acceso remoto

Controlador com possibilidade de acesso remoto

| | | |
|---|---|----------------------|
|  | Consola DMX-RDM programable. 1536 canales DMX. 99 escenas, 5 zonas. Ethernet. microSD. Servicio cloud disponible no incluido para la gestión remota de la instalación. Requiere conocimientos de programación DMX. Instalación a carril DIN. 12V dc. Consola DMX-RDM programável. 1536 canais DMX. 99 cenas, 5 zonas. Ethernet. microSD. Serviço cloud disponível, mas não incluído, para a gestão remota da instalação. Requer conhecimentos de programação DMX. Instalação em calha DIN. 12V dc. | 71-B667-00-00 |
|  | Pantalla táctil 7" negra, para control DMX compatible con controlador 71-B667-00-00. USB-A Ethernet RJ45 WiFi (2,4 GHz), 1024x600. 9V DC (incorporado). Ecrã tátil 7" preto para controlo DMX compatível com o controlador 71-B667-00-00. USB-A Ethernet RJ45 Wi-fi (2,4 GHz), 1024x600. 9V DC (incorporado). | 71-B863-00-00 |







Accesos Cloud

Accesos Cloud

| | | |
|---|---|-----------------|
|  | Servicio Digital Cloud DMX Connect Essential, Anual. Serviço Digital Cloud DMX Connect Essential, anual. | SV-D0101 |
|  | Servicio Digital Cloud DMX Connect Performance Anual. Serviço Digital Cloud DMX Connect Performance Anual. | SV-D0102 |

Gestión de contenidos Madrix

Gestão de conteúdos Madrix

| | | |
|---|---|----------------------|
|  | Controlador Artnet-SPI Madrix Nebula. 12 universos SPI (hasta 2048 RGB píxeles por dispositivo). Entradas Art-Net, sACN y USB. Instalación carril DIN, 5-24 V Controlador Artnet-SPI Madrix Nebula. 12 universos SPI (até 2048 RGB píxeles por dispositivo). Entradas Art-Net, sACN e USB. Instalação calha DIN, 5-24 V | 71-C268-00-00 |
|  | Controlador Artnet-DMX. 2 universos DMX (hasta 1024 canales). Entradas/salidas Art-Net, sACN y USB. Instalación carril DIN, 5-24 V Controlador Artnet-DMX. 2 universos DMX (até 1024 canais). Entradas/salidas Art-Net, sACN e USB. Instalação calha DIN, 5-24 V | 71-C269-00-00 |
|  | Controlador StandAlone Madrix Aura. 2 universos DMX (hasta 1024 canales). Entradas/salidas Art-Net, sACN y USB. Instalación carril DIN, 5-24 V Controlador StandAlone Madrix Aura. 2 universos DMX (até 1024 canais). Entradas/salidas Art-Net, sACN e USB. Instalação calha DIN, 5-24 V | 71-C270-00-00 |
|  | Controlador StandAlone Madrix Aura. 12 universos DMX (hasta 6.144 canales). Grabación de secuencias Art-Net/ sACN mediante microSD. Instalación carril DIN, 5-24 V Controlador Stand-Alone Madrix Aura. 12 universos DMX (até 6144 canais). Gravação de sequências Art-Net/ sACN mediante microSD. Instalação calha DIN, 5-24 V | 71-C271-00-00 |
|  | Controlador StandAlone Madrix Aura. 12 universos DMX (hasta 6.144 canales). Grabación de secuencias Art-Net/ sACN mediante microSD. Instalación carril DIN, 5-24 V Controlador Stand-Alone Madrix Aura. 12 universos DMX (até 6144 canais). Gravação de sequências Art-Net/ sACN mediante microSD. Instalação calha DIN, 5-24 V | 71-C280-00-00 |
|  | Licencia básica de software MADRIX para control avanzado de iluminación LED. Conexión vía USB. Licença básica de software MADRIX para controlo avançado de iluminação LED. Ligação via USB. | 71-C272-00-00 |
|  | Licencias para Madrix en función de los universos DMX. A consultar. Licenças MADRIX baseadas nos universos DMX. Consultar o departamento técnico. | |

Standalone

Soluciones de control autónomas. Pueden utilizarse para controlar una o varias luminarias dentro de un mismo espacio de forma autónoma. Con las soluciones Standalone podemos realizar funciones sencillas y conseguir un gran ahorro energético.

Soluções de controlo autónomas. Podem ser utilizadas para controlar uma ou várias luminárias dentro de um mesmo espaço de forma autónoma. Com as soluções Standalone podemos realizar funções simples e conseguir uma grande poupança energética.



Institut Vilabreix, 2022

Gracias a la incorporación de sensores autónomos, la iluminación se regula en función del aporte de luz natural, favoreciendo el ahorro energético.

Graças à incorporação de sensores autónomos, a iluminação é regulada de acordo com o fornecimento de luz natural, favorecendo a poupança energética.

Botoneras y regulador DALI para instalación en caja universal de mecanismos

Botoneiras e regulador DALI para instalação numa caixa universal de mecanismos



Pantalla táctil RGBW PWM para regular 1 zona para tiras LED y producto a tensión constante 12-24V, 4 canales de 5A. Permite guardar 4 colores. Requiere fuente de alimentación. Instalación en caja universal de mecanismos de 65x65. **71-7664-00-00**
Ecrã tátil RGBW PWM para regular 1 zona para fitas LED e produto de tensão constante 12-24V, 4 canais de 5A. Permite guardar 4 cores. Necessário fonte de alimentação. Instalação numa caixa universal de derivação de 65x65.



Pantalla táctil DMX básica no programable. Controla simultaneamente luminarias DMX "Broadcast". Permite guardar 4 colores. Instalación en caja universal de mecanismos de 65x65. 100-240V. **71-7666-00-00**
Ecrã tátil DMX básico, não programável. Controla simultaneamente luminárias DMX "Broadcast". Permite guardar 4 cores. Instalação numa caixa universal de derivação de 65x65. 100-240V.

Controladores con mando a distancia por radiofrecuencia

Controladores com comando à distância por radiofrequência



Mando a distancia para receptor 71-7668-00-00, 1 canal, 6 escenas, 6 zonas.
Comando à distância para recetor 71-7668-00-00, 1 canal, 6 cenas, 6 zonas.

71-7670-00-00



Receptor radiofrecuencia para tiras led y producto a tensión constante 12-48Vdc. 1 canal de 8A. Puede actuar como Master o Esclavo. Máxima distancia de sincronización de 30metros. 6 zonas. Requiere fuente de alimentación. 24Vdc.
Recetor de radiofrequência para fitas LED e produto de tensão constante 12-48Vdc. 1 canal de 8A. Pode atuar como Master ou Escravo. Distância máxima de sincronização de 30 metros. 6 zonas. Necessário fonte de alimentação. 24Vdc.

71-7668-00-00



Mando a distancia para receptor 71-7669-00-00, 4 canales RGBW, 6 zonas.
Comando à distância para recetor 71-7669-00-00, 4 canais RGBW, 6 zonas.





71-7667-00-00





Receptor radiofrecuencia para tiras led y producto a tensión constante 12-48Vdc. 4 canales de 5A. Puede actuar como Master o Esclavo. Máxima distancia de sincronización de 30metros. 6 zonas. Requiere fuente de alimentación. 24Vdc.
Recetor de radiofrequência para fitas LED e produto de tensão constante 12-48Vdc. 4 canais de 5A. Pode atuar como Master ou Escravo. Distância máxima de sincronização de 30 metros. 6 zonas. Necessário fonte de alimentação. 24Vdc.

71-7669-00-00



Pantallas táctiles DALI para instalación en caja universal de mecanismos**Ecrãs táteis DALI para instalação numa caixa universal de derivação**

| | | |
|---|--|----------------------|
|  | <p>Convertor de señales libre de potencial, apto para incorporar pulsadores convencionales al entorno DALI2. Permite controlar hasta 64 equipos DALI-2 en modo broadcast. Alimentación a 230V</p> <p>Convertor de sinais sem potencial, adequado para incorporar botões convencionais no ambiente DALI2. Permite controlar até 64 equipamentos DALI-2 em modo broadcast. Alimentação a 230V</p> | 71-C276-00-00 |
|  | <p>Dimmer DALI, 1 zona para máximo 50 drivers. Controla simultáneamente luminarias DALI "Broadcast". Instalacion en caja universal de mecanismos de 65×65. 100-240V</p> <p>Dimmer DALI, 1 zona para o máximo de 50 drivers. Controla simultaneamente as luminárias DALI "Broadcast". Instalação numa caixa universal de derivação de 65×65. 100-240V</p> | 71-7671-00-00 |
|  | <p>Dimmer DALI, 4 zonas para máximo 50 drivers. Instalación en caja universal de mecanismos de 65×65. Requiere direccionamiento de grupos DALI y por tanto conocimientos de programación DALI. Alimentación DALI.</p> <p>Dimmer DALI, 4 zonas para o máximo de 50 drivers. Instalação numa caixa universal de derivação de 65×65. Requer o direccionamento de grupos DALI e, por conseguinte, conhecimentos de programação DALI. Alimentação DALI.</p> | 71-7665-00-00 |
|  | <p>Dimmer DALI2 DT8 para productos con blanco dinámico. Máximo 25 drivers. Controla simultáneamente "broadcast" luminarias DALI DT8. Instalación en caja universal de mecanismos de 65×65. 230V.</p> <p>Dimmer DALI2 DT8 para produtos com branco dinámico. Máximo de 25 drivers. Controla simultaneamente "broadcast" luminárias DALI DT8. Instalação numa caixa universal de derivação de 65×65. 230V</p> | 71-B361-00-00 |

Controladores PWM 12-24V**Controlador PWM 12-24V**

| | | |
|---|---|----------------------|
|  | <p>Controlador 1-10V PWM para tiras LED y producto a tensión constante 12-24V, 2 canales de 6,5A. Requiere fuente de alimentación.</p> <p>Controlador 1-10V para fitas LED e produto de tensão constante de 12-24V, 2 canais, 6,5A. Necessário fonte de alimentação.</p> | 71-0727-00-00 |
|  | <p>Controlador DMX-RDM PWM para tiras LED y producto a tensión constante 12-24V, 5 canales de 8A. Requiere fuente de alimentación. Puertos RJ45, XLR y de tornillo. Dispone de modo esclavo DMX o de modo master para funcionamiento autónomo.</p> <p>Controlador DMX-RDM PWM para fitas LED e produtos com tensão constante 12-24V, 5 canais de 8A. Necessário fonte de alimentação. Portas RJ45, XLR e de parafuso. Possui modo escravo DMX ou modo master para funcionamento autónomo.</p> | 71-B755-00-00 |

Sensores**Sensores**

| | | |
|---|--|----------------------|
|  | <p>Sensor On off con salida rele de hasta 6A. Diámetro de detección de movimiento 6,8m a 3m altura de instalación. 95-250V</p> <p>Sensor on-off com saída de relé até 6A. Diâmetro de deteção de movimento de 6,8 m e 3 m de altura. 95-250V</p> | 71-B368-00-00 |
|  | <p>Sensor DALI hasta 16 luminarias, para funcionamiento autónomo, control de las luminarias simultáneamente "broadcast". Diámetro de detección de movimiento de 6m a 3m de altura. De 5-a 1000lx de luminosidad. 95-250V</p> <p>Sensor DALI até 16 luminárias, para funcionamento autónomo, controlo das luminárias simultaneamente "broadcast". Diâmetro de deteção de movimento de 6 m e 3 m de altura. De 5 a 1000lx de luminosidade. 95-250V</p> | 71-8067-00-00 |
|  | <p>Sensor D4i hasta 4 luminarias DALI, para funcionamiento autónomo, integrable en luminaria. Diámetro de detección de movimiento 6m a 3m de altura. De 5 a 1000lx de luminosidad. Alimentación DALI-D4i necesaria.</p> <p>Sensor D4i até 4 luminárias DALI, para funcionamento autónomo, integrável na luminária. Diâmetro de deteção de movimento de 6 m a 3 m de altura. De 5 a 1000lx de luminosidade. Necessária alimentação DALI-D4i.</p> | 71-A723-00-00 |

Extra Reader's Guide

Recomendaciones de instalación

Recomendações de instalação

Productos con driver remoto

Se recomienda instalar el driver a un máximo de 2 metros del producto cuando no sea posible verificar los niveles de EMC de cada aplicación, según lo establecido en las normas de referencia. Es necesario verificar la polaridad de los cables del producto antes de conectarlos al secundario del driver, ya que un mal conexionado puede dañar el módulo LED y/o el driver.

Regulación

Los cables de señal de regulación deben instalarse separados de los cables de potencia. No está permitido poner interruptores en el secundario del driver.

Regulación por línea (corte de fase)

- Regulación básica por línea, no requiere cables adicionales.
- Productos con driver de regulación tipo "L": admiten regulación con dimmers tipo TRIAC/IGBT; regulación por inicio de fase (leading edge/forward phase control).
- Productos con driver de regulación tipo "C": admiten regulación con dimmers tipo IGBT; regulación por final de fase (trailing edge/reverse phase control).
- Productos con driver tipo "LC" admiten los dos tipos de dimmers especificados anteriormente.
- Se recomienda verificar la compatibilidad dimmer-driver.

Regulación Push

Requiere un cable adicional. Deben utilizarse pulsadores NA (normalmente abiertos). Una pulsación rápida enciende o apaga el producto. Si se mantiene accionado el pulsador se ajusta el nivel de brillo.

Regulación 0/1-10V

Regulación analógica que requiere dos cables adicionales con polaridad. Un dimmer genera una señal a tensión constante entre 0 y 10V. Si se aplica una tensión de 1V el driver ajustará el brillo del producto al mínimo, sin embargo cuando se aplique una tensión de 10V el producto brillará al máximo. Los drivers que admiten una señal de regulación con rango entre 0-10V son capaces de apagar el producto por completo al recibir 0V del dimmer.

Control DALI/DALI-2

Protocolo de control digital desarrollado por los principales fabricantes de drivers para crear un estándar de regulación en el sector de la iluminación. Permite memorizar escenas, enviar mensajes en caso de fallo o final de vida del producto, control y planificación punto a punto del producto y gestión de emergencias. Requiere dos cables adicionales sin polaridad. Se recomienda utilizar cable de sección 1.5mm². La certificación DALI-2 mejora la interoperabilidad entre dispositivos DALI.

Control DMX

Protocolo de control digital utilizado en el mundo de la iluminación espectacular. Requiere dos cables adicionales con polaridad. Se recomienda el uso de cable trenzado, apantallado y con impedancia 120Ω.

Control Casambi

Sistema de control Bluetooth Mesh

Se recomienda no superar los 15m de distancia entre dispositivos, ni utilizar envolventes metálicas que afecten a su comunicación inalámbrica.

Produtos com driver remoto

Recomenda-se instalar o driver no máximo a 2 metros do produto quando não for possível verificar os níveis de EMC de cada aplicação, conforme o estabelecido nas normas de referência. É necessário verificar a polaridade dos cabos do produto antes de os conectar ao secundário do driver, já que uma má conexão pode danificar o módulo LED e/ou o driver.

Regulação

Os cabos de sinal de regulação devem ser instalados separados dos cabos de potência. Não é permitido colocar interruptores no secundário do driver.

Regulação por linha (corte de fase)

- Regulação básica por linha, não requer cabos adicionais.
- Produtos com driver de regulação tipo "L": admitem regulação com dimmers tipo TRIAC/IGBT; regulação por início de fase (leading edge/forward phase control).
- Produtos com driver de regulação tipo "C": admitem regulação com dimmers tipo IGBT; regulação por final de fase (trailing edge/reverse phase control).
- Produtos com driver tipo "LC" admitem os dois tipos de dimmers especificados anteriormente.
- Recomenda-se verificar a compatibilidade dimmer-driver.

Regulação Push

Requer um cabo adicional. Devem ser utilizados botões NA (normalmente abertos). Uma pressão rápida liga ou desliga o produto. Mantendo-se o botão pressionado ajusta-se o nível de brilho.

Regulação 0/1-10V

Regulação analógica que requer dois cabos adicionais com polaridade. Um dimmer gera um sinal de tensão constante entre 0 e 10V. Se for aplicada uma tensão de 1V, o driver ajustará o brilho do produto no mínimo, contudo quando for aplicada uma tensão de 10V o produto brilhará no máximo. Os drivers que admitem sinal de regulação com um intervalo entre 0-10V são capazes de desligar completamente o produto ao receber 0V do dimmer.

Controlo DALI/DALI-2

Protocolo de controlo digital desenvolvido pelos principais fabricantes de drivers para criar um standard de regulação no setor da iluminação. Permite a memorização de cenários, enviar mensagens em caso de falha ou fim de vida do produto, controlo e planificação ponto a ponto do produto e gestão de emergências. Requer dois cabos adicionais sem polaridade. Recomenda-se utilizar um cabo de secção de 1,5 mm². A certificação DALI-2 melhora a interoperabilidade entre os dispositivos DALI.

Controlo DMX

Protocolo de controlo digital utilizado no mundo da iluminação espectacular. Requer dois cabos adicionais com polaridade. Recomenda-se o uso de cabo trançado, blindado e com impedância de 120Ω.

Controlo Casambi

Sistema de controlo Bluetooth Mesh

Recomenda-se não ultrapassar os 15 m de distância entre dispositivos, nem utilizar envolventes metálicas que afetem a sua comunicação sem fios.

Información técnica

Informação técnica



EMPOTRABLES DE TIERRA – DRENAJE

Es imprescindible seguir las instrucciones de montaje y la guía de instalación de los empotrables para lograr el mejor funcionamiento posible de la luminaria.

1. Evitar colocar las luminarias en zonas de depresión del terreno.
2. Evitar colocar las luminarias en zonas donde se pueda acumular agua y en ubicaciones permanentemente húmedas, como jardines o césped.
3. Evitar el uso de productos químicos utilizados para el abono de jardines ya que pueden deteriorar algunos componentes.
4. Nivelar la luminaria con el pavimento.
5. Prever un recubrimiento de dilatación en el caso de empotrables colocados en superficies como el cemento o el hormigón para evitar la posible dilatación o compresión.
6. Colocar un drenaje eficaz para evitar el estancamiento de agua, como mínimo de 25 centímetros de grava por debajo de la carcasa de instalación. Un drenaje correcto debe absorber hasta 10 litros de agua en 15 minutos.
7. Hacer funcionar la luminaria durante 20 minutos sin el cristal para evitar condensaciones de agua dentro.

ENCASTRÁVEIS NO SOLO – DRENAGEM

É imprescindível que siga as instruções de montagem e o guia de instalação dos encastráveis para obter o melhor funcionamento possível do aparelho de iluminação.

1. Evite colocar os aparelhos de iluminação em zonas de depressão do terreno.
2. Evite colocar os aparelhos de iluminação em zonas onde se possa acumular água e em localizações permanentemente húmidas, como jardins ou relva.
3. Evite o uso de produtos químicos utilizados para o adubamento de jardins, dado que eles podem deteriorar alguns componentes.
4. Nivele o aparelho de iluminação pelo pavimento.
5. Preveja um revestimento de dilatação no caso de encastráveis colocados em superfícies como o cimento ou o betão para evitar a eventual dilatação ou compressão.
6. Coloque uma drenagem eficaz para evitar a estagnação da água, no mínimo de 25 centímetros de gravilha abaixo da carcaça de instalação. Uma drenagem correcta deve absorver até 10 litros de água em 15 minutos.
7. Faça funcionar o aparelho de iluminação durante 20 minutos sem o vidro para evitar condensações de água dentro dele.

Controladores / Controladores

| | |
|---|---------------|
| Controlador PWM 12-24V para tiras LED / Controlador PWM 12-24V para fitas LED | 71-7664-00-00 |
|---|---------------|

RF controladores remotos / RF Controladores remotos

| | |
|----------------------------------|---------------|
| Receptor RGB / Recetor RGB | 71-7669-00-00 |
| Mando RGB / Comando RGB | 71-7667-00-00 |
| Receptor blanco / Recetor branco | 71-7670-00-00 |
| Mando blanco / Comando branco | 71-7668-00-00 |

Reguladores DALI Básicos / Reguladores DALI Básicos

| | |
|---|---------------|
| Regulador DALI 1CH / Regulador DALI 1CH | 71-7671-00-00 |
| Regulador DALI DT8 2CH TW / Regulador DALI DT8 2CH TW | 71-B361-00-00 |
| Regulador DALI 4 zonas / Regulador DALI 4 zonas | 71-7665-00-00 |

Dispositivos DMX / Dispositivos DMX

| | |
|--|---------------|
| Controlador DMX / Controlador DMX | 71-B755-00-00 |
| Regulador DMX básico / Regulador DMX básico | 71-7666-00-00 |
| Consola DMX esencial con pantalla táctil / Consola DMX essencial com ecrã tátil | 71-B115-00-00 |
| Consola DMX performance con pantalla táctil / Consola DMX performance com ecrã tátil | 71-B116-00-00 |
| Consola DMX advance / Consola DMX advance | 71-B667-00-00 |
| Divisor / amplificador 4 outputs / Divisor / amplificador 4 outputs | 71-B125-00-00 |
| Divisor / amplificador 10 outputs / Divisor / amplificador 10 outputs | 71-B668-00-00 |
| Fuente de alimentación D51mm 12V 12W / Fonte de alimentação D51mm 12V 12W | 71-B416-00-00 |

Drivers



| L x W x H mm | IP | CLASS | V in | V out | Constant current Iout (mA) | Potencia máxima (W) Potência máxima (W) | Protocol | |
|----------------|----|-------|----------|----------|-------------------------------|--|---------------------------|----------------------|
| 47,5×27,2×20 | 20 | □ | 220-240V | 2,7-4,5V | 700 | 3 | ON-OFF | 71-B781-00-00 |
| 76×22×20 | 20 | □ | 220-240V | 2,5-4,5V | 700 | 3 | ON-OFF | 71-B682-00-00 |
| 300×47×47 | 67 | □ | 100-240V | 2-4V | 1200 | 4,8 | ON-OFF | 71-E225-05-05 |
| 66,3×38,5×21,8 | 20 | □ | 100-240V | 8,6-18V | 350 | 6 | ON-OFF | 71-A652-00-00 |
| 123×45×19 | 20 | □ | 100-240V | 5-13V | 700 | 9 | ON-OFF | 71-B232-00-00 |
| 165×45×37 | 68 | □ | 100-240V | 6-14,5V | 700 | 10 | ON-OFF | 71-E014-00-00 |
| 300×47×47 | 67 | □ | 100-240V | 6-14,5V | 700 | 10 | ON-OFF | 71-E226-05-05 |
| 158×22×19 | 20 | □ | 90-264V | 2-27V | 500 | 14 | ON-OFF | 71-B406-00-00 |
| 115×34×19 | 20 | □ | 90-264V | 1-41,5V | 60-360 | 15 | ON-OFF | 71-E218-00-00 |
| 158×22×19 | 20 | □ | 100-240V | 2-40V | 350 | 15 | ON-OFF | 71-7699-00-00 |
| 123×45×19 | 20 | □ | 100-240V | 23-46V | 350 | 16,1 | ON-OFF | 71-6652-00-00 |
| 121,5×53,5×26 | 68 | □ | 99-264V | 2-49V | 350 | 17 | ON-OFF | 71-E079-00-00 |
| 130×38×28 | 20 | □ | 110-240V | 2-14V | 1400 | 18 | ON-OFF | 71-E217-00-00 |
| 165×45×37 | 67 | □ | 100-240V | 15-29V | 700 | 20 | ON-OFF | 71-E015-00-00 |
| 115×29×45 | 20 | □ | 100-240V | 10-29V | 700 | 20,3 | ON-OFF | 71-6658-00-00 |
| 111×52×22 | 20 | □ | 100-240V | 16-42V | 500 | 21 | ON-OFF | 71-C111-00-00 |
| 105×68×32 | 20 | □ | 100-240V | 21-43V | 700 | 30,1 | ON-OFF | 71-6653-00-00 |
| 105×68×32 | 20 | □ | 100-240V | 21-42V | 1050 | 44,1 | ON-OFF | 71-6661-00-00 |
| 124×79×22 | 20 | □ | 110-240V | 0-74V | 350-1050 | 50 | ON-OFF | 71-3542-00-00 |
| 129×76×30 | 20 | □ | 99-264V | 48V | 1050-2100 | 55 | ON-OFF | 71-4914-00-00 |
| 101,5×49×29 | 20 | □ | 220-240V | 27-42V | 350 | 14 | PHASE-CUT 230V | 71-A297-00-00 |
| 111×52×22 | 20 | □ | 220-240V | 25-51V | 350 | 18 | PHASE-CUT 230V | 71-C337-00-00 |
| 102×38×21 | 20 | □ | 220-240V | 6-14V | 700 | 10 | PHASE-CUT 230V | 71-7663-00-00 |
| 111×52×22 | 20 | □ | 220-240V | 16-42V | 500 | 20 | PHASE-CUT 230V | 71-C338-00-00 |
| 145×51×29,5 | 20 | □ | 220-240V | 17-39V | 700 | 25 | PHASE-CUT 230V | 71-A299-00-00 |
| 166×47×35 | 20 | □ | 220-240V | 2-47V | 350-750 | 32 | PHASE-CUT 230V-PUSH | 71-4898-00-00 |
| 150×43×25 | 20 | □ | 100-240V | 5-13V | 700 | 9 | DALI2; PUSH | 71-A190-00-00 |
| 150×43×25 | 20 | □ | 100-240V | 23-46V | 350 | 16 | DALI2; PUSH | 71-A191-00-00 |
| 135×80×31 | 68 | □ | 99-264V | 10-50V | 350 | 17,5 | 0-10V; 1-10V; DALI2 | 71-E083-00-00 |
| 97,3×41×22 | 20 | □ | 110-277V | 8-40V | 150-500 | 20 | DALI2 | 71-B407-00-00 |
| 152×46×36 | 20 | □ | 100-240V | 10-43V | 350-700 | 30 | DALI2; PUSH | 71-A192-00-00 |
| 135×80×31 | 68 | □ | 99-264V | 10-50V | 500 | 25 | DALI2 | 71-E085-00-00 |
| 121,5×53,5×26 | 68 | □ | 99-264V | 2-49V | 700 | 30 | DALI2 | 71-E080-00-00 |
| 146×44×30 | 20 | □ | 220-240V | 10-54V | 300-1050 | 38 | DALI2; PUSH | 71-A303-00-00 |
| 124×79×22 | 20 | □ | 110-240V | 2-74V | 350-1050 | 60 | PUSH; 0-10V; 1-10V; DALI2 | 71-4706-00-00 |
| 135×80×31 | 68 | □ | 99-264V | 10-50V | 1200mA | 60 | 0-10V; 1-10V; DALI2 | 71-E518-00-00 |
| 135×80×31 | 68 | □ | 99-264V | 10-50V | 700mA | 70 | 0-10V; 1-10V; DALI2 | 71-E086-00-00 |

Equipos de control / Equipamentos de controlo

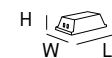

□ IP20 □

| L x W x H mm | IP | CLASS | V in | Frecuencia Frequência | Potencia máxima (W) Potência máxima (W) | Protocol | |
|----------------|----|-------|----------------------|--------------------------|--|------------------------|----------------------|
| 40,4×36,3×14 | 20 | □ | 220-240V 12-24V | 50-60Hz | Max.150W (230V) | CASAMBI-RLC | 71-5959-00-00 |
| 56,5×35,8×22,3 | 20 | □ | 24-48V 220-240V | 50-60Hz | Max. 1 driver | CASAMBI- DALI/O-10V | 71-5961-00-00 |
| 30×72,6×18 | 66 | ⊕ | 100-240V 100-240V | | Max.144W | CASAMBI-PWM | 71-8050-00-00 |
| 143×18×59 | 20 | ⊕ | 100-240V 47-63Hz | | Max. 64 devices | CASAMBI-DALI | 71-8115-00-00 |
| 108×108×62 | 67 | □ | 90-305V 47-63Hz | 50-60Hz | Max. 64 devices | CASAMBI-DALI | 71-A237-00-00 |
| 108×108×62 | 67 | □ | 90-305V 47-63Hz | 50-60Hz | Max. 32 devices | CASAMBI-DMX | 71-A238-00-00 |
| 91×45×124 | 67 | ◇ | 90-305V 47-63Hz | 50-60Hz | Max. 64 devices | CASAMBI | 71-A243-14-14 |
| 91×45×124 | 67 | ◇ | 90-305V 47-63Hz | 50-60Hz | Max. 64 devices | CASAMBI | 71-A243-60-60 |



| L x W x H mm | IP | CLASS | V in | Constant voltage Vdc (V) | Potencia máxima (W) Potência máxima (W) | Protocol | |
|--------------|----|-------|----------|-----------------------------|--|-------------|----------------------|
| 51×49×27 | 20 | | 220-240V | 12 | 12 | ON-OFF | 71-B416-00-00 |
| 188×50×33,5 | 67 | | 90-305V | 12 | 96 | ON-OFF | 71-B676-00-00 |
| 146×55×19 | 20 | | 100-240V | 12 | 20 | ON-OFF | 71-B677-00-00 |
| 146×55×19 | 20 | | 100-240V | 24 | 20 | ON-OFF | 71-B650-00-00 |
| 300×30×16 | 20 | | 220-240V | 24 | 30 | ON-OFF | 71-B640-00-00 |
| 350×30×18 | 20 | | 220-240V | 24 | 100 | ON-OFF | 71-B641-00-00 |
| 350×30×18 | 20 | | 220-240V | 24 | 150 | ON-OFF | 71-B642-00-00 |
| 400×40×22 | 20 | | 220-240V | 24 | 250 | ON-OFF | 71-B643-00-00 |
| 205×42×10 | 67 | | 100-240V | 24 | 20 | ON-OFF | 71-E101-05-05 |
| 250×30×21 | 67 | | 220-240V | 24 | 30 | ON-OFF | 71-B644-00-00 |
| 290×30×21 | 67 | | 220-240V | 24 | 60 | ON-OFF | 71-B645-00-00 |
| 320×30×21 | 67 | | 220-240V | 24 | 100 | ON-OFF | 71-B646-00-00 |
| 350×30×21 | 67 | | 220-240V | 24 | 160 | ON-OFF | 71-B647-00-00 |
| 400×30×21 | 67 | | 220-240V | 24 | 240 | ON-OFF | 71-B648-00-00 |
| 400×60×22 | 67 | | 220-240V | 24 | 400 | ON-OFF | 71-B649-00-00 |
| 300×30×16 | 20 | | 220-240V | 24 | 60 | DALI2 | 71-B652-00-00 |
| 350×30×16 | 20 | | 220-240V | 24 | 150 | DALI2 | 71-B653-00-00 |
| 290×30×21 | 67 | | 220-240V | 24 | 60 | DALI2 | 71-B655-00-00 |
| 350×30×21 | 67 | | 220-240V | 24 | 160 | DALI2 | 71-B656-00-00 |
| 191×63×38 | 67 | | 90-305V | 24 | 120 | CASAMBI;PWM | 71-A242-00-00 |
| 180×52×30 | 20 | | 220-240V | 48 | 75 | ON-OFF | 71-A258-00-00 |
| 300×40×30 | 20 | | 220-240V | 48 | 120 | ON-OFF | 71-A259-00-00 |
| 350×30×18 | 20 | | 220-240V | 48 | 150 | ON-OFF | 71-B658-00-00 |
| 350×30×18 | 20 | | 220-240V | 48 | 250 | ON-OFF | 71-B659-00-00 |
| 320×30×21 | 67 | | 220-240V | 48 | 100 | ON-OFF | 71-B660-00-00 |
| 350×30×21 | 67 | | 220-240V | 48 | 160 | ON-OFF | 71-B661-00-00 |
| 400×30×21 | 67 | | 220-240V | 48 | 240 | ON-OFF | 71-B662-00-00 |
| 252×90×44 | 67 | | 90-305V | 48 | 320 | ON-OFF | 71-B077-00-00 |
| 297×16×19 | 20 | | 220-240V | 48 | 100 | ON-OFF | 71-B440-60-00 |
| 268×43×22 | 20 | | 220-240V | 48 | 250 | ON-OFF | 71-B441-60-00 |

Key to Symbols

440

Acabados
Acabamentos































441







Materiales
Materiais

442

Simbología
Simbologia

Acabados / Acabamentos





















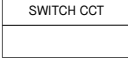

| | | | |
|--|----|------------------|------------------|
|  | 00 | Blanco | Branco |
|  | 01 | Oro | Ouro |
|  | 05 | Negro | Preto |
|  | 06 | Cobre | Cobre |
|  | 08 | Verde | Verde |
|  | 12 | Fumé | Fumado |
|  | 14 | Blanco | Branco |
|  | 15 | Ámbar | Ámbar |
|  | 21 | Cromo | Cromado |
|  | 23 | Oro | Ouro |
|  | 27 | Latonado | Latão |
|  | 34 | Gris | Cinzento |
|  | 37 | Transparente | Transparente |
|  | 60 | Negro | Preto |
|  | 81 | Níquel satinado | Níquel acetinado |
|  | 92 | Fresno oscuro | Cinza escura |
|  | 93 | Fresno claro | Cinzento claro |
|  | BW | Blanco | Branco |
|  | BY | Arena | Areia |
|  | B8 | Cristal satinado | Vidro acetinado |
|  | CI | Marrón | Castanho |
|  | CS | Gris cemento | Cinzento cimento |
|  | DL | Oro | Ouro |
|  | DN | Oro mate | Ouro mate |
|  | DO | Latón pulido | Latão polido |
|  | EF | Oro | Ouro |
|  | EK | Gris oscuro | Cinza escuro |
|  | EM | Gris piedra | Cinzento pedra |
|  | EQ | Marrón claro | Castanho claro |
|  | ES | Rattan natural | Rattan natural |
|  | ET | Oro pintado | Ouro pintado |
|  | EU | Blanco brillante | Branco brilhante |
|  | EV | Negro brillante | Preto brilhante |

| | | | |
|---|----|---------------------------------|-------------------------------|
|  | EX | Gris oliva | Cinzeno oliva |
|  | F1 | Cristal arenado | Vidro fosco |
|  | F5 | Oro | Ouro |
|  | F9 | Arenado | Areado |
|  | FF | Arena | Areia |
|  | GA | Fieltro gris claro | Feltro cinzeno claro |
|  | GB | Fieltro gris oscuro | Feltro cinzeno escuro |
|  | G5 | Cristal pintado blanco interior | Vidro pintado branco interior |
|  | W1 | Marrón Caoba | Castanho Caoba |
|  | L1 | Terracota jaspeado | Terracota jaspeado |
|  | K3 | Cristal espejo | Vidro espelho |
|  | M1 | Blanco opal | Branco opalino |
|  | M3 | Anodizado | Anodizado |























Materiales / Materiais

| | | |
|----------------|---------------------------|-------------------------|
| ABS | ABS | ABS |
| ACR | Acrílico | Acrílico |
| AISI202 | Acero inoxidable AISI 202 | Aço inoxidável AISI 202 |
| AISI304 | Acero inoxidable AISI 304 | Aço inoxidável AISI 304 |
| AISI316 | Acero inoxidable AISI 316 | Aço inoxidável AISI 316 |
| AL | Aluminio | Alumínio |
| ALAB | Alabastro | Alabastro |
| BR | Latón | Latão |
| CON | Cemento | Cimento |
| FELT | Fieltro | Feltro |
| G | Grafeno | Grafeno |
| GL | Fibra de vidrio | Fibra de vidro |
| GLA | Cristal | Vidro |
| PC | Polycarbonato | Polycarbonato |
| PC+ABS | Polycarbonato + ABS | Polycarbonato + ABS |
| PLABS | Plástico | Plástico |
| PLSTER | Yeso | Gesso |
| PMMA | PMMA | PMMA |
| POLI | Tecnopolímero | Tecnopolímero |
| PP | Polipropileno | Polipropileno |
| PUR | Poliuretano | Poliuretano |
| PVC | PVC | PVC |
| R | Resina | Resina |
| RATAN | Ratan | Rattan |
| ST | Acero | Aço |
| TEX | Textil | Têxtil |
| WASHI | Papel japonés | Papel japonês |
| WOOD | Madera | Madeira |
| WOODT | Madera de teca | Madeira de teca |





















Simbología / Simbologia

| | | |
|--|---|---|
|  | Sistema de codificación para indicar el grado de protección proporcionado por un envolvente contra la entrada de elementos sólidos y líquidos | Sistema de codificação para a indicação do grau de proteção proporcionado por um envolvente contra a entrada de objetos sólidos e líquidos |
|  | Material de la estructura | Material da estrutura |
|  | Sistema de codificación para indicar el grado de protección proporcionado por un envolvente contra los impactos mecánicos nocivos. Energía de impacto (Jules) | Sistema de codificação para a indicação do grau de proteção proporcionado por um envolvente contra os impactos mecânicos nocivos. Energia de impacto (joules) |
|  | Material del difusor | Material do difusor |
|  | UGR | UGR |
|  | Low Flicker | Low Flicker |
|  | Clase I | Classe I |
|  | Clase II | Classe II |
|  | Clase III | Classe III |
|  | Horas de vida | Horas de vida |
|  | Cumple con la eficacia luminosa exigida para obtener el certificado de construcción sostenible BREEAM, calculada dividiendo los lúmenes reales por la potencia total de la luminaria. | Cumpr e a eficácia luminosa exigida para obter o certificado de construção sustentável BREEAM, calculada pela divisão dos lúmenes reais pela potência total da luminária. |
|  | MacAdam | MacAdam |
|  | WELL. Contribuye al cumplimiento de la característica L06 según el WELL Building Standard®. | WELL. Contribui para o cumprimento da característica L06 de acordo com o WELL Building Standard®. |
|  | Switch CCT | Switch CCT |
|  | RGB Light | RGB Light |
|  | Luminarias no adecuadas para cubrirse con material aislante térmico | Luminárias não adequadas para serem cobertas com material isolante térmico |
|  | Luminarias no adecuadas para el montaje directo en superficies normalmente inflamables | Luminárias não adequadas para a montagem direta em superfícies normalmente inflamáveis |
|  | ATENCIÓN - Esta luminaria puede soportar una carga estática limitada. ES APTA para zonas donde eventualmente circulan vehículos a baja velocidad. NO ES APTA para zonas de paso habitual de vehículos | ATENÇÃO - Esta luminária pode suportar uma carga estática limitada. É ADEQUADA para zonas onde, eventualmente, circulam veículos a baixa velocidade. NÃO É ADEQUADA para zonas de passagem habitual de veículos |
|  | Nº de metros máximos. de conexión en serie | Nº de metros máximo de ligação em série |
|  | x metros de cable | x metros de cabo |
|  | Doble salida de cable | Dupla saída de cabos |
|  | Precableado (20cm) con 4 conectores rápidos estancos (hembra + hembra a la izquierda y macho + macho a la derecha). | Pré-cablagem (20cm) com 4 conectores rápidos estanques (fêmea + fêmea à esquerda e macho + macho à direita). |
|  | Precableado (20cm) y con 2 conectores rápidos estancos incluidos (hembra a la izquierda y macho a la derecha). | Pré-cablagem (20cm) com 2 conectores rápidos estanques (fêmea à esquerda e macho à direita). |
|  | Precableado (20cm) con 2 conectores rápidos estancos (macho a la izquierda y macho a la derecha). | Pré-cablagem (20cm) com 2 conectores rápidos estanques (macho à esquerda e macho à direita). |

Simbología / Simbologia

| | | |
|---|---|---|
|  | Precableado (20cm) con 1 conector rápido estanco (macho). | Pré-cablagem (20cm) com 1 conetor rápido estanque (macho). |
|  | Precableado (20cm) con 1 conector rápido estanco (macho). Incluye 1 premsaestopas extra. | Pré-cablado (20cm) com 1 conetor rápido estanque (macho). Inclui 1 bucim extra pré-cablado. |
|  | Precableado (20cm) con 4 conectores rápidos estancos (todos hembra). | Pré-cablagem (20cm) com 4 conectores rápidos estanques (todos fêmea). |
|  | Luminaria adecuada para instalar en ambientes con atmósfera marina. La garantía no cubre el cambio de color o el deterioro de la pintura causado por la luz solar y/o el ambiente salino, a no ser que afecte la seguridad mecánica y estructural del producto. En ambientes marinos se debe hacer un mantenimiento cada 6 meses como máximo para eliminar eventuales depósitos de sal. | Luminária adequada para instalar em ambientes com atmosfera marinha. A garantia não cobre a mudança de cor ou a deterioração da pintura causada pela luz solar e/ou ambiente salino, a menos que afete a segurança mecânica e estrutural do produto. Em ambientes marinhos, deve-se fazer uma manutenção a cada 6 meses, no máximo, para eliminar eventuais depósitos de sal. |
|  | Sistema de regulación DIMABLE. | Sistema de regulação DIMMÁVEL |
|  | Sistema de regulación NO DIMABLE. | Sistema de regulação NO DIMMÁVEL. |
|  | Drenaje. Ver las recomendaciones de instalación en la pág. 432. | Drenagem. Ver as recomendações de instalação na pág. 432. |
|  | Incluye sistema de fijación al suelo desarrollada por LedsC4 que garantiza la robustez y durabilidad de las luminarias y que entre ellas no haya diferencias de inclinación aunque el suelo sea irregular. | Inclui um sistema de fixação ao solo desenvolvido pela LedsC4 que garante a robustez e durabilidade das luminárias e que entre elas não existam diferenças de inclinação, mesmo que o solo seja irregular. |
|  | Orientable | Orientável |
|  | Orientable | Orientável |
|  | Orientable | Orientável |
|  | Orientable | Orientável |
|  | Orientable | Orientável |
|  | Orientable | Orientável |
|  | Orientable | Orientável |
|  | Orientable | Orientável |
|  | Interruptor de encendido | Interruptor de ligar/desligar |
|  | Doble interruptor de encendido | Duplo interruptor de ligar/desligar |
|  | Interruptor táctil | Interruptor tátil |
|  | Interruptor de encendido en el cable | Interruptor de ligar/desligar no fio |
|  | Espejo de aumento x5 | Espelho de aumento x5 |
|  | Espejo de aumento x3 | Espelho de aumento x3 |
|  | Mando a distancia | Comando à distância |

Simbología / Simbologia

| | | |
|---|--|--|
|  xm | Nº de metros máximos. de conexión en serie | Nº de metros máximo de ligação em série |
|  ANTI FOG | Antifog. Sistema incluido para evitar que el espejo se empañe con el vapor de agua. | Antineblina. Sistema incluido para evitar que o espelho embacice com o vapor de água. |
|  SAFETY BACK | La lámina de seguridad es una película aplicada en el reverso de los espejos para evitar las lesiones causadas en caso de rotura del cristal. | A lâmina de segurança é uma película aplicada na parte posterior dos espelhos para evitar lesões provocadas em caso de quebra do vidro. |
|  | Luminaria apta para el paso de vehículos según normativa EN 60598-2-13 (ensayos de resistencia a la torsión y carga cortante). | Luminária adequada à passagem de veículos segundo a norma EN 60598-2-13 (ensaios de resistência à torção e força cortante). |
| AIRFLOW | Airflow (CFM). Unidad de medida del caudal de aire del ventilador (pies cúbicos por minuto). | Airflow (CFM). Unidade de medida do caudal de ar do ventilador (pés cúbicos por minuto). |
| DC MOTOR | DC Motors. Motor de corriente continua. Mejor eficiencia y consumo. | DC Motors. Motor de corrente contínua. Melhor eficiência e consumo. |
|  | Incorpora fuente de luz | Incorpora fonte de luz |
| BLADES MAT | Material de las palas | Material das lâminas |
|  | La función inversa hace girar las palas en sentido contrario. Durante los meses de frío, permite desplazar el aire caliente desde el techo hasta el suelo y calentar la estancia ahorrando energía usándolo con el sistema de calefacción. | A função inversa faz rodar as lâminas em sentido contrário. Durante os meses frios, permite deslocar o ar quente do teto para o chão e aquecer a divisão poupando energia utilizando-o com o sistema de aquecimento. |
|  x2 | Velocidad de ventilación, velocidad de giro del motor. | Velocidade de ventilação, velocidade de rotação do motor. |
|  USB | Conexión USB | Ligação USB |
|  USB C | Conexión USB-C | Ligação USB-C |
|  | Corte a medida | Corte à medida |
|  | Fuente de luz no reemplazable | Fonte de luz não substituível |
|  | Fuente de luz reemplazable por un técnico cualificado | Fonte de luz substituível por um técnico qualificado |
|  | Fuente de luz reemplazable por el usuario final | Fonte de luz substituível pelo usuário final |
|  | Driver no reemplazable | Driver não substituível |
|  | Driver reemplazable por un técnico cualificado | Driver substituível por um técnico qualificado |
|  | Driver reemplazable por el usuario final | Driver substituível pelo usuário final |
|  | Wireless | Wireless |
|  | Sensor | Sensor |
|  | Luminarias con conectividad integrada. | Luminárias com conectividade integrada. |
|  | Equipo no incluido | Equipamento não incluído |
|  | Equipo incluido | Equipamento incluído |

Simbología / Simbologia

| | | |
|-------------------|--|---|
| STANDBY LIGHTING | Luminaria con kit de autonomía integrado para continuidad de servicio en caso de fallo de red. Ideal para zonas donde se requiera iluminación de apoyo no sujeta a requisitos de evacuación normativa. | Luminária com kit de autonomia integrado para continuidade de serviço em caso de falha de rede. Ideal para zonas onde seja necessária iluminação de apoio não sujeita a requisitos normativos de evacuação. |
| UNE-EN 60598-2-22 | Cumple con los requisitos generales que se aplican a las luminarias de emergencia. | Cumpre os requisitos gerais aplicáveis às luminárias de emergência. |
| | Los anclajes permiten su instalación en techos de X mm a X mm | As fixações permitem a sua instalação em tetos de X mm a X mm |
| | Consultar disponibilidad | Consultar Disponibilidade |
| | Diámetro de empotramiento | Diâmetro de encastramento |
| | Corte de empotramiento | Corte de encastramento |
| | El driver sí pasa por el agujero de empotrar | O driver passa pelo orifício de encastrar |
| | El driver no pasa por el agujero de empotrar | O driver não passa pelo orifício de encastrar |
| | Variación de la temperatura de color de blanco cálido a frío | Variação da temperatura de cor de branco quente a frio |
| | Quick Service 2-6 días laborables (tiempo de transporte no incluido) | Quick Service 2-6 dias úteis (tempo de transporte não incluído) |

Índice por referencias / Índice por referências

| Referencia Referência | Pág. Pág. | Referencia Referência | Pág. Pág. | Referencia Referência | Pág. Pág. | Referencia Referência | Pág. Pág. |
|--------------------------|--------------|--------------------------|--------------|--------------------------|--------------|--------------------------|--------------|
| 00-0001-XX-XX | 166 | 00-7398-XX-XX | 135 | 00-8385-XX-XX | 139 | 00-A056-XX-XX | 72 |
| 00-0002-XX-XX | 166 | 00-7399-XX-XX | 135 | 00-8389-XX-XX | 139 | 00-A057-XX-XX | 73 |
| 00-0641-XX-XX | 166 | 00-7400-XX-XX | 134 | 00-8392-XX-XX | 125 | 00-A058-XX-XX | 69 |
| 00-0642-XX-XX | 166 | 00-7401-XX-XX | 134 | 00-8395-XX-XX | 125 | 00-A059-XX-XX | 73 |
| 00-3642-XX-XX | 167 | 00-7402-XX-XX | 135 | 00-8403-XX-XX | 99 | 00-A060-XX-XX | 69 |
| 00-3646-XX-XX | 167 | 00-7403-XX-XX | 135 | 00-8405-XX-XX | 99 | 00-A061-XX-XX | 70 |
| 00-3647-XX-XX | 167 | 00-7404-XX-XX | 135 | 00-8406-XX-XX | 99 | 00-A062-XX-XX | 70 |
| 00-3648-XX-XX | 167 | 00-7405-XX-XX | 135 | 00-8513-XX-XX | 155 | 00-A063-XX-XX | 73 |
| 00-3649-XX-XX | 167 | 00-7589-XX-XX | 121 | 00-8514-XX-XX | 155 | 00-A064-XX-XX | 71 |
| 00-4925-XX-XX | 176 | 00-7591-XX-XX | 121 | 00-8527-XX-XX | 147 | 00-A065-XX-XX | 71 |
| 00-4926-XX-XX | 176 | 00-7685-XX-XX | 85 | 00-8528-XX-XX | 147 | 00-A066-XX-XX | 71 |
| 00-5456-XX-XX | 171 | 00-7686-XX-XX | 85 | 00-8533-XX-XX | 149 | 00-A067-XX-XX | 71 |
| 00-5693-XX-XX | 153 | 00-7687-XX-XX | 85 | 00-8534-XX-XX | 149 | 00-A068-XX-XX | 71 |
| 00-5694-XX-XX | 153 | 00-7688-XX-XX | 85 | 00-8535-XX-XX | 150 | 00-A069-XX-XX | 71 |
| 00-5695-XX-XX | 153 | 00-7689-XX-XX | 85 | 00-8536-XX-XX | 150 | 00-A070-XX-XX | 71 |
| 00-5696-XX-XX | 153 | 00-7690-XX-XX | 85 | 00-8537-XX-XX | 148 | 00-A071-XX-XX | 71 |
| 00-6010-XX-XX | 94 | 00-7691-XX-XX | 84 | 00-8646-XX-XX | 158 | 00-A072-XX-XX | 70 |
| 00-6011-XX-XX | 94 | 00-7692-XX-XX | 84 | 00-8648-XX-XX | 158 | 00-A073-XX-XX | 70 |
| 00-6012-XX-XX | 94 | 00-7693-XX-XX | 84 | 00-8656-XX-XX | 158 | 00-A074-XX-XX | 70 |
| 00-6013-XX-XX | 94 | 00-7694-XX-XX | 84 | 00-8658-XX-XX | 158 | 00-A075-XX-XX | 70 |
| 00-6017-XX-XX | 147 | 00-7695-XX-XX | 84 | 00-8667-XX-XX | 158 | 00-A076-XX-XX | 71 |
| 00-6018-XX-XX | 147 | 00-7696-XX-XX | 84 | 00-8669-XX-XX | 158 | 00-A077-XX-XX | 71 |
| 00-6021-XX-XX | 148 | 00-7727-XX-XX | 119 | 00-8902-XX-XX | 110 | 00-A078-XX-XX | 71 |
| 00-6303-XX-XX | 85 | 00-7728-XX-XX | 119 | 00-8933-XX-XX | 110 | 00-A079-XX-XX | 71 |
| 00-6304-XX-XX | 85 | 00-7729-XX-XX | 119 | 00-8953-XX-XX | 110 | 00-A080-XX-XX | 72 |
| 00-6305-XX-XX | 85 | 00-7730-XX-XX | 119 | 00-9003-XX-XX | 115 | 00-A081-XX-XX | 72 |
| 00-6306-XX-XX | 84 | 00-7731-XX-XX | 119 | 00-9007-XX-XX | 133 | 00-A082-XX-XX | 72 |
| 00-6307-XX-XX | 84 | 00-7732-XX-XX | 119 | 00-9032-XX-XX | 122 | 00-A083-XX-XX | 72 |
| 00-6308-XX-XX | 84 | 00-7742-XX-XX | 142 | 00-9033-XX-XX | 128 | 00-A084-XX-XX | 72 |
| 00-6314-XX-XX | 85 | 00-7899-XX-XX | 163 | 00-9034-XX-XX | 128 | 00-A085-XX-XX | 72 |
| 00-6315-XX-XX | 85 | 00-7900-XX-XX | 163 | 00-9035-XX-XX | 128 | 00-A086-XX-XX | 72 |
| 00-6316-XX-XX | 85 | 00-7901-XX-XX | 163 | 00-9036-XX-XX | 128 | 00-A087-XX-XX | 72 |
| 00-6317-XX-XX | 84 | 00-7984-XX-XX | 115 | 00-9042-XX-XX | 133 | 00-A088-XX-XX | 69 |
| 00-6318-XX-XX | 84 | 00-7986-XX-XX | 115 | 00-9043-XX-XX | 133 | 00-A089-XX-XX | 69 |
| 00-6319-XX-XX | 84 | 00-7992-XX-XX | 144 | 00-9044-XX-XX | 134 | 00-A090-XX-XX | 69 |
| 00-6452-XX-XX | 94 | 00-7993-XX-XX | 144 | 00-9045-XX-XX | 134 | 00-A091-XX-XX | 69 |
| 00-6454-XX-XX | 94 | 00-8107-XX-XX | 103 | 00-9046-XX-XX | 134 | 00-A092-XX-XX | 69 |
| 00-6455-XX-XX | 94 | 00-8108-XX-XX | 103 | 00-9047-XX-XX | 135 | 00-A093-XX-XX | 69 |
| 00-6457-XX-XX | 94 | 00-8248-XX-XX | 69 | 00-9048-XX-XX | 135 | 00-A094-XX-XX | 69 |
| 00-6458-XX-XX | 94 | 00-8261-XX-XX | 70 | 00-9049-XX-XX | 135 | 00-A095-XX-XX | 69 |
| 00-6460-XX-XX | 94 | 00-8271-XX-XX | 70 | 00-9050-XX-XX | 142 | 00-A096-XX-XX | 75 |
| 00-6461-XX-XX | 94 | 00-8276-XX-XX | 72 | 00-9052-XX-XX | 142 | 00-A097-XX-XX | 75 |
| 00-6463-XX-XX | 94 | 00-8280-XX-XX | 73 | 00-9053-XX-XX | 142 | 00-A098-XX-XX | 75 |
| 00-6666-XX-XX | 149 | 00-8285-XX-XX | 73 | 00-A015-XX-XX | 101 | 00-A099-XX-XX | 75 |
| 00-6667-XX-XX | 149 | 00-8292-XX-XX | 69 | 00-A016-XX-XX | 101 | 00-A100-XX-XX | 75 |
| 00-6668-XX-XX | 150 | 00-8296-XX-XX | 70 | 00-A017-XX-XX | 173 | 00-A101-XX-XX | 75 |
| 00-6669-XX-XX | 150 | 00-8299-XX-XX | 70 | 00-A018-XX-XX | 173 | 00-A102-XX-XX | 75 |
| 00-6670-XX-XX | 161 | 00-8301-XX-XX | 73 | 00-A019-XX-XX | 121 | 00-A103-XX-XX | 75 |
| 00-6671-XX-XX | 161 | 00-8302-XX-XX | 158 | 00-A020-XX-XX | 121 | 00-A104-XX-XX | 74 |
| 00-7382-XX-XX | 153 | 00-8303-XX-XX | 158 | 00-A024-XX-XX | 90 | 00-A105-XX-XX | 74 |
| 00-7383-XX-XX | 153 | 00-8304-XX-XX | 158 | 00-A025-XX-XX | 90 | 00-A106-XX-XX | 74 |
| 00-7384-XX-XX | 153 | 00-8305-XX-XX | 158 | 00-A026-XX-XX | 90 | 00-A107-XX-XX | 74 |
| 00-7385-XX-XX | 153 | 00-8306-XX-XX | 158 | 00-A027-XX-XX | 91 | 00-A108-XX-XX | 73 |
| 00-7388-XX-XX | 133 | 00-8307-XX-XX | 158 | 00-A028-XX-XX | 91 | 00-A109-XX-XX | 73 |
| 00-7389-XX-XX | 133 | 00-8317-XX-XX | 148 | 00-A041-XX-XX | 91 | 00-A110-XX-XX | 73 |
| 00-7390-XX-XX | 133 | 00-8337-XX-XX | 164, 369 | 00-A042-XX-XX | 90 | 00-A111-XX-XX | 73 |
| 00-7391-XX-XX | 133 | 00-8348-XX-XX | 138 | 00-A043-XX-XX | 90 | 00-A112-XX-XX | 74 |
| 00-7392-XX-XX | 133 | 00-8364-XX-XX | 138 | 00-A044-XX-XX | 90 | 00-A113-XX-XX | 74 |
| 00-7393-XX-XX | 133 | 00-8365-XX-XX | 138 | 00-A045-XX-XX | 91 | 00-A114-XX-XX | 74 |
| 00-7394-XX-XX | 134 | 00-8369-XX-XX | 138 | 00-A046-XX-XX | 91 | 00-A115-XX-XX | 74 |
| 00-7395-XX-XX | 134 | 00-8373-XX-XX | 138 | 00-A047-XX-XX | 91 | 00-A116-XX-XX | 74 |
| 00-7396-XX-XX | 134 | 00-8377-XX-XX | 139 | 00-A054-XX-XX | 70 | 00-A117-XX-XX | 74 |
| 00-7397-XX-XX | 134 | 00-8381-XX-XX | 139 | 00-A055-XX-XX | 70 | 00-A118-XX-XX | 74 |

Índice por referencias / Índice por referências

| | | | | | | | |
|---------------|----|---------------|-----|---------------|------------------|---------------|----------|
| 00-A119-XX-XX | 74 | 00-A197-XX-XX | 73 | 05-6396-XX-XX | 367 | 05-A018-XX-XX | 68 |
| 00-A126-XX-XX | 70 | 00-A198-XX-XX | 73 | 05-6420-XX-XX | 192 | 05-A019-XX-XX | 68 |
| 00-A127-XX-XX | 70 | 00-A199-XX-XX | 73 | 05-6421-XX-XX | 192 | 05-A020-XX-XX | 67 |
| 00-A128-XX-XX | 70 | 00-A200-XX-XX | 74 | 05-6428-XX-XX | 193 | 05-A021-XX-XX | 68 |
| 00-A129-XX-XX | 70 | 00-A201-XX-XX | 74 | 05-6488-XX-XX | 195 | 05-A022-XX-XX | 67 |
| 00-A130-XX-XX | 72 | 00-A202-XX-XX | 74 | 05-7366-XX-XX | 200 | 05-A023-XX-XX | 67 |
| 00-A131-XX-XX | 72 | 00-A203-XX-XX | 74 | 05-7367-XX-XX | 200 | 05-A024-XX-XX | 68 |
| 00-A132-XX-XX | 73 | 00-A204-XX-XX | 74 | 05-7380-XX-XX | 185 | 05-A025-XX-XX | 68 |
| 00-A133-XX-XX | 73 | 00-A205-XX-XX | 74 | 05-7381-XX-XX | 185 | 05-A026-XX-XX | 291 |
| 00-A134-XX-XX | 69 | 00-A206-XX-XX | 74 | 05-7382-XX-XX | 185 | 05-A027-XX-XX | 291 |
| 00-A135-XX-XX | 69 | 00-A207-XX-XX | 74 | 05-7383-XX-XX | 185 | 05-A028-XX-XX | 291 |
| 00-A136-XX-XX | 73 | 00-A232-XX-XX | 163 | 05-7385-XX-XX | 293 | 05-A029-XX-XX | 67 |
| 00-A137-XX-XX | 73 | 00-A294-XX-XX | 110 | 05-7387-XX-XX | 311, 349, 370 | 05-A030-XX-XX | 67 |
| 00-A138-XX-XX | 69 | 00-A295-XX-XX | 110 | 05-7388-XX-XX | 303 | 05-A031-XX-XX | 67 |
| 00-A139-XX-XX | 69 | 00-A296-XX-XX | 110 | 05-7389-XX-XX | 303 | 05-A032-XX-XX | 68 |
| 00-A140-XX-XX | 70 | 00-A337-XX-XX | 163 | 05-7573-XX-XX | 315 | 05-A033-XX-XX | 68 |
| 00-A141-XX-XX | 70 | 00-A338-XX-XX | 111 | 05-7574-XX-XX | 315 | 05-A034-XX-XX | 68 |
| 00-A142-XX-XX | 70 | 00-A339-XX-XX | 111 | 05-7574-XX-XX | 315 | 05-A035-XX-XX | 67 |
| 00-A143-XX-XX | 70 | 00-A340-XX-XX | 111 | 05-7575-XX-XX | 315 | 05-A036-XX-XX | 67 |
| 00-A144-XX-XX | 73 | 00-A341-XX-XX | 111 | 05-7576-XX-XX | 315 | 05-A037-XX-XX | 67 |
| 00-A145-XX-XX | 73 | 00-A342-XX-XX | 111 | 05-7582-XX-XX | 308 | 05-A038-XX-XX | 67 |
| 00-A146-XX-XX | 71 | 00-A343-XX-XX | 111 | 05-7588-XX-XX | 298 | 05-A039-XX-XX | 67 |
| 00-A147-XX-XX | 71 | 00-A344-XX-XX | 111 | 05-7606-XX-XX | 189 | 05-A040-XX-XX | 67 |
| 00-A148-XX-XX | 71 | 00-A345-XX-XX | 111 | 05-7742-XX-XX | 307 | 05-A041-XX-XX | 68 |
| 00-A149-XX-XX | 71 | 00-A346-XX-XX | 111 | 05-7831-XX-XX | 365 | 05-A042-XX-XX | 68 |
| 00-A150-XX-XX | 71 | 00-A347-XX-XX | 111 | 05-7833-XX-XX | 365 | 05-A043-XX-XX | 68 |
| 00-A151-XX-XX | 71 | 00-A348-XX-XX | 111 | 05-7982-XX-XX | 197 | 05-A044-XX-XX | 68 |
| 00-A152-XX-XX | 71 | 00-A349-XX-XX | 111 | 05-8102-XX-XX | 291 | 05-A045-XX-XX | 68 |
| 00-A153-XX-XX | 71 | 00-A350-XX-XX | 109 | 05-8103-XX-XX | 291 | 05-A076-XX-XX | 277, 359 |
| 00-A154-XX-XX | 70 | 00-A351-XX-XX | 109 | 05-8104-XX-XX | 291 | 05-A077-XX-XX | 277, 359 |
| 00-A155-XX-XX | 70 | 00-A352-XX-XX | 109 | 05-8249-XX-XX | 67 | 05-A078-XX-XX | 183 |
| 00-A156-XX-XX | 70 | 00-A353-XX-XX | 109 | 05-8250-XX-XX | 67 | 05-A088-XX-XX | 325 |
| 00-A157-XX-XX | 70 | 00-A354-XX-XX | 109 | 05-8255-XX-XX | 67 | 05-A091-XX-XX | 316 |
| 00-A158-XX-XX | 71 | 00-A355-XX-XX | 109 | 05-8279-XX-XX | 68 | 05-A102-XX-XX | 367 |
| 00-A159-XX-XX | 71 | 00-A356-XX-XX | 109 | 05-8329-XX-XX | 190 | 05-A103-XX-XX | 319 |
| 00-A166-XX-XX | 71 | 00-A357-XX-XX | 109 | 05-8335-XX-XX | 353 | 05-A104-XX-XX | 319 |
| 00-A167-XX-XX | 71 | 00-A358-XX-XX | 109 | 05-8336-XX-XX | 353 | 05-A105-XX-XX | 319 |
| 00-A168-XX-XX | 72 | 00-A359-XX-XX | 109 | 05-8337-XX-XX | 369 | 05-A109-XX-XX | 51 |
| 00-A169-XX-XX | 72 | 00-A360-XX-XX | 109 | 05-8339-XX-XX | 194 | 05-A110-XX-XX | 51 |
| 00-A170-XX-XX | 72 | 00-A361-XX-XX | 109 | 05-8348-XX-XX | 305 | 05-E202-XX-XX | 321 |
| 00-A171-XX-XX | 72 | 00-A366-XX-XX | 110 | 05-8356-XX-XX | 284 | 05-E203-XX-XX | 321 |
| 00-A172-XX-XX | 72 | 00-A367-XX-XX | 110 | 05-8357-XX-XX | 284 | 05-E206-XX-XX | 322 |
| 00-A173-XX-XX | 72 | 00-A368-XX-XX | 110 | 05-8358-XX-XX | 287 | 05-E207-XX-XX | 321 |
| 00-A174-XX-XX | 72 | 00-A369-XX-XX | 110 | 05-8359-XX-XX | 284 | 05-E209-XX-XX | 297 |
| 00-A175-XX-XX | 72 | 00-A370-XX-XX | 110 | 05-8360-XX-XX | 284 | 05-E210-XX-XX | 297 |
| 00-A176-XX-XX | 69 | 00-A371-XX-XX | 110 | 05-8361-XX-XX | 285 | 10-4759-XX-XX | 237 |
| 00-A177-XX-XX | 69 | 00-A372-XX-XX | 51 | 05-8362-XX-XX | 285 | 10-5693-XX-XX | 227 |
| 00-A178-XX-XX | 69 | 00-A373-XX-XX | 51 | 05-8363-XX-XX | 285 | 10-6010-XX-XX | 219 |
| 00-A179-XX-XX | 69 | 00-A374-XX-XX | 51 | 05-8399-XX-XX | 313 | 10-6011-XX-XX | 219 |
| 00-A180-XX-XX | 69 | 00-A375-XX-XX | 51 | 05-8400-XX-XX | 205 | 10-6420-XX-XX | 228 |
| 00-A181-XX-XX | 69 | 00-A376-XX-XX | 51 | 05-8401-XX-XX | 206 | 10-7385-XX-XX | 227 |
| 00-A182-XX-XX | 69 | 00-A377-XX-XX | 51 | 05-8509-XX-XX | 187 | 10-7582-XX-XX | 229 |
| 00-A183-XX-XX | 69 | 00-A378-XX-XX | 51 | 05-8510-XX-XX | 191 | 10-7742-XX-XX | 216 |
| 00-A184-XX-XX | 75 | 05-1793-XX-XX | 324 | 05-8513-XX-XX | 295 | 10-7982-XX-XX | 230 |
| 00-A185-XX-XX | 75 | 05-1794-XX-XX | 324 | 05-8515-XX-XX | 312 | 10-8102-XX-XX | 223 |
| 00-A186-XX-XX | 75 | 05-2759-XX-XX | 196 | 05-8540-XX-XX | 203 | 10-8327-XX-XX | 243 |
| 00-A187-XX-XX | 75 | 05-2830-XX-XX | 199 | 05-9007-XX-XX | 303 | 10-8350-XX-XX | 237 |
| 00-A188-XX-XX | 75 | 05-2831-XX-XX | 199 | 05-9683-XX-XX | 323 | 10-8516-XX-XX | 233 |
| 00-A189-XX-XX | 75 | 05-4401-XX-XX | 317 | 05-A005-XX-XX | 367 | 10-8518-XX-XX | 233 |
| 00-A190-XX-XX | 75 | 05-5085-XX-XX | 299 | 05-A011-XX-XX | 288, 361 | 10-8540-XX-XX | 235 |
| 00-A191-XX-XX | 75 | 05-5296-XX-XX | 201 | 05-A012-XX-XX | 363 | 10-9055-XX-XX | 225 |
| 00-A192-XX-XX | 74 | 05-5306-XX-XX | 310 | 05-A013-XX-XX | 67 | 10-A001-XX-XX | 247 |
| 00-A193-XX-XX | 74 | 05-5307-XX-XX | 310 | 05-A014-XX-XX | 68 | 10-A002-XX-XX | 215 |
| 00-A194-XX-XX | 74 | 05-5478-XX-XX | 355 | 05-A015-XX-XX | 67 | 10-A003-XX-XX | 215 |
| 00-A195-XX-XX | 74 | 05-5693-XX-XX | 293 | 05-A016-XX-XX | 67 | 10-A004-XX-XX | 215 |
| 00-A196-XX-XX | 73 | 05-6193-XX-XX | 198 | 05-A017-XX-XX | 68 | 10-A005-XX-XX | 215 |

Índice por referencias / Índice por referências

| | | | | | | | |
|---------------|----------|---------------|------------------|---------------|------------------|---------------|-------------------------------|
| 10-A009-XX-XX | 211 | 15-A366-XX-XX | 338 | 71-8067-XX-XX | 429 | 71-B662-XX-XX | 435 |
| 10-A026-XX-XX | 223 | 15-A367-XX-XX | 338 | 71-8115-XX-XX | 423, 434 | 71-B667-XX-XX | 427, 433 |
| 10-A078-XX-XX | 220 | 15-A368-XX-XX | 338 | 71-8318-XX-XX | 147, 148 | 71-B668-XX-XX | 427, 433 |
| 15-0073-XX-XX | 354 | 25-4759-XX-XX | 271 | 71-8332-XX-XX | 243, 247 | 71-B669-XX-XX | 423 |
| 15-4370-XX-XX | 371 | 25-5693-XX-XX | 263 | 71-8497-XX-XX | 66 | 71-B670-XX-XX | 424 |
| 15-4922-XX-XX | 177, 348 | 25-6420-XX-XX | 264 | 71-8498-XX-XX | 66 | 71-B671-XX-XX | 424 |
| 15-6196-XX-XX | 169, 345 | 25-7385-XX-XX | 263 | 71-A190-XX-XX | 434 | 71-B672-XX-XX | 424 |
| 15-6197-XX-XX | 169, 345 | 25-7582-XX-XX | 253 | 71-A191-XX-XX | 434 | 71-B673-XX-XX | 424 |
| 15-6433-XX-XX | 169, 345 | 25-7742-XX-XX | 259 | 71-A192-XX-XX | 434 | 71-B674-XX-XX | 424 |
| 15-7723-XX-XX | 85 | 25-8102-XX-XX | 261 | 71-A237-XX-XX | 423, 434 | 71-B676-XX-XX | 435 |
| 15-7982-XX-XX | 353 | 25-8350-XX-XX | 271 | 71-A238-XX-XX | 423, 434 | 71-B677-XX-XX | 435 |
| 15-8330-XX-XX | 309, 347 | 25-8394-XX-XX | 257 | 71-A240-XX-XX | 424 | 71-B682-XX-XX | 434 |
| 15-8331-XX-XX | 309, 347 | 25-8520-XX-XX | 267 | 71-A241-XX-XX | 425 | 71-B743-XX-XX | 425 |
| 15-8514-XX-XX | 352 | 25-8521-XX-XX | 267 | 71-A242-XX-XX | 424, 435 | 71-B750-XX-XX | 425 |
| 15-8902-XX-XX | 338 | 25-8522-XX-XX | 267 | 71-A243-XX-XX | 423, 434 | 71-B755-XX-XX | 427, 429, 433, 437 |
| 15-8933-XX-XX | 338 | 25-8540-XX-XX | 269 | 71-A258-XX-XX | 435 | 71-B756-XX-XX | 421 |
| 15-8953-XX-XX | 338 | 25-8566-XX-XX | 257 | 71-A259-XX-XX | 435 | 71-B781-XX-XX | 434 |
| 15-A052-XX-XX | 177, 348 | 25-A001-XX-XX | 252 | 71-A297-XX-XX | 434 | 71-B830-XX-XX | 421 |
| 15-A125-XX-XX | 279, 342 | 25-A002-XX-XX | 252 | 71-A299-XX-XX | 434 | 71-B831-XX-XX | 421 |
| 15-A126-XX-XX | 279, 342 | 25-A026-XX-XX | 261 | 71-A300-XX-XX | 423 | 71-B849-XX-XX | 419 |
| 15-A127-XX-XX | 279, 342 | 25-A076-XX-XX | 255 | 71-A303-XX-XX | 434 | 71-B850-XX-XX | 420 |
| 15-A128-XX-XX | 280, 343 | 30-5378-XX-XX | 406 | 71-A652-XX-XX | 434 | 71-B853-XX-XX | 427 |
| 15-A129-XX-XX | 280, 343 | 30-7973-XX-XX | 402 | 71-A696-XX-XX | 425 | 71-B855-XX-XX | 423 |
| 15-A130-XX-XX | 280, 343 | 30-8548-XX-XX | 412 | 71-A723-XX-XX | 429 | 71-B863-XX-XX | 427 |
| 15-A131-XX-XX | 330 | 30-A001-XX-XX | 394 | 71-A857-XX-XX | 424 | 71-B864-XX-XX | 424 |
| 15-A132-XX-XX | 330 | 71-0073-XX-XX | 354, 171, 196 | 71-B077-XX-XX | 435 | 71-B865-XX-XX | 424 |
| 15-A133-XX-XX | 330 | 71-0727-XX-XX | 429 | 71-B098-XX-XX | 420 | 71-B866-XX-XX | 424 |
| 15-A134-XX-XX | 331 | 71-3542-XX-XX | 434 | 71-B099-XX-XX | 421 | 71-B876-XX-XX | 420 |
| 15-A135-XX-XX | 331 | 71-4695-XX-XX | 177 | 71-B100-XX-XX | 420 | 71-B877-XX-XX | 420 |
| 15-A136-XX-XX | 331 | 71-4706-XX-XX | 434 | 71-B101-XX-XX | 420 | 71-B908-XX-XX | 419 |
| 15-A137-XX-XX | 330 | 71-4898-XX-XX | 434 | 71-B102-XX-XX | 419 | 71-B909-XX-XX | 419 |
| 15-A138-XX-XX | 330 | 71-4914-XX-XX | 434 | 71-B103-XX-XX | 419 | | |
| 15-A139-XX-XX | 330 | 71-5166-XX-XX | 97 | 71-B113-XX-XX | 424 | | 393, 396, 398, 400, 410 |
| 15-A140-XX-XX | 331 | 71-5167-XX-XX | 97 | 71-B115-XX-XX | 426, 433 | 71-B940-XX-XX | |
| 15-A141-XX-XX | 331 | 71-5658-XX-XX | 97 | 71-B116-XX-XX | 426, 433 | | |
| 15-A142-XX-XX | 331 | 71-5959-XX-XX | 423, 434 | 71-B117-XX-XX | 421 | 71-C012-XX-XX | 419 |
| 15-A294-XX-XX | 338 | 71-5961-XX-XX | 423, 434 | 71-B125-XX-XX | 427, 433 | 71-C013-XX-XX | 420 |
| 15-A295-XX-XX | 338 | 71-6022-XX-XX | 147 | 71-B232-XX-XX | 434 | 71-C014-XX-XX | 420 |
| 15-A296-XX-XX | 338 | 71-6099-XX-XX | 97 | 71-B361-XX-XX | 429, 433 | 71-C111-XX-XX | 434 |
| 15-A297-XX-XX | 338 | 71-6196-XX-XX | 169 | 71-B368-XX-XX | 429 | 71-C253-XX-XX | 48 |
| 15-A298-XX-XX | 338 | 71-6652-XX-XX | 434 | 71-B401-XX-XX | 420 | 71-C254-XX-XX | 48 |
| 15-A299-XX-XX | 338 | 71-6653-XX-XX | 434 | 71-B406-XX-XX | 434 | 71-C255-XX-XX | 48 |
| 15-A338-XX-XX | 339 | 71-6658-XX-XX | 434 | 71-B407-XX-XX | 434 | 71-C256-XX-XX | 48 |
| 15-A339-XX-XX | 339 | 71-6661-XX-XX | 434 | | | 71-C257-XX-XX | 48 |
| 15-A340-XX-XX | 339 | 71-7660-XX-XX | 308 | 71-B416-XX-XX | 427, 433, 435 | 71-C258-XX-XX | 48 |
| 15-A341-XX-XX | 339 | 71-7663-XX-XX | 434 | 71-B440-XX-XX | 435 | 71-C259-XX-XX | 48 |
| 15-A342-XX-XX | 339 | 71-7664-XX-XX | 428, 433, 437 | 71-B441-XX-XX | 435 | 71-C260-XX-XX | 48 |
| 15-A343-XX-XX | 339 | 71-7665-XX-XX | 429, 433 | 71-B640-XX-XX | 435, 436 | 71-C261-XX-XX | 48 |
| 15-A344-XX-XX | 339 | 71-7666-XX-XX | 426, 428, 433 | 71-B641-XX-XX | 435, 436 | 71-C262-XX-XX | 48 |
| 15-A345-XX-XX | 339 | 71-7667-XX-XX | 428, 433 | 71-B642-XX-XX | 435, 436 | 71-C263-XX-XX | 48 |
| 15-A346-XX-XX | 339 | 71-7668-XX-XX | 428, 433, 437 | 71-B643-XX-XX | 435, 436 | 71-C264-XX-XX | 48 |
| 15-A347-XX-XX | 339 | 71-7669-XX-XX | 428, 433, 437 | 71-B644-XX-XX | 435, 436 | 71-C265-XX-XX | 48 |
| 15-A348-XX-XX | 339 | 71-7670-XX-XX | 428, 433 | 71-B645-XX-XX | 435, 436 | 71-C266-XX-XX | 48 |
| 15-A349-XX-XX | 339 | 71-7671-XX-XX | 429, 433 | 71-B646-XX-XX | 435, 436 | 71-C268-XX-XX | 427 |
| 15-A350-XX-XX | 337 | 71-7679-XX-XX | 434 | 71-B647-XX-XX | 435, 436 | 71-C269-XX-XX | 427 |
| 15-A351-XX-XX | 337 | 71-7895-XX-XX | 97 | 71-B648-XX-XX | 435, 436 | 71-C270-XX-XX | 427 |
| 15-A352-XX-XX | 337 | 71-8049-XX-XX | 425 | 71-B649-XX-XX | 435, 436 | 71-C271-XX-XX | 427 |
| 15-A353-XX-XX | 337 | 71-8050-XX-XX | 424, 434 | 71-B650-XX-XX | 435, 436 | 71-C272-XX-XX | 427 |
| 15-A354-XX-XX | 337 | 71-8051-XX-XX | 423 | 71-B652-XX-XX | 435, 437 | 71-C274-XX-XX | 423 |
| 15-A355-XX-XX | 337 | 71-8052-XX-XX | 425 | 71-B653-XX-XX | 435, 437 | 71-C275-XX-XX | 423 |
| 15-A356-XX-XX | 337 | 71-8053-XX-XX | 424 | 71-B655-XX-XX | 435, 437 | 71-C276-XX-XX | 429 |
| 15-A357-XX-XX | 337 | | | 71-B656-XX-XX | 435, 437 | 71-C277-XX-XX | 420, 427 |
| 15-A358-XX-XX | 337 | | | 71-B658-XX-XX | 435 | 71-C278-XX-XX | 420 |
| 15-A359-XX-XX | 337 | | | 71-B659-XX-XX | 435 | 71-C280-XX-XX | 427 |
| 15-A360-XX-XX | 337 | | | 71-B660-XX-XX | 435 | 71-C337-XX-XX | 434 |
| 15-A361-XX-XX | 337 | | | 71-B661-XX-XX | 435 | 71-C338-XX-XX | 434 |

Índice por referencias / Índice por referências

| | | | | | | | |
|---------------|-------------------------------|-----------------|------------------|-------------------------|------------------|-------------|-----|
| 71-C340-XX-XX | 393, 396, 398, 400, 410 | 71-E518-XX-XX | 434 | PAN-177-XX | 206, 313, 237 | VE-0091-XXX | 398 |
| 71-C341-XX-XX | 393 | 75-8508-XX-XX | 373 | PAN-178-XX | 206, 313 | VE-0092-XXX | 396 |
| 71-C351-XX-XX | 425 | AV14-XXXXXXXXXX | 97 | PAN-179-XX | 206, 313, 237 | VE-0093-XXX | 410 |
| 71-C352-XX-XX | 425 | AV15-XXXXXXXXXX | 97 | PAN-232-XX | 203 | VE-0094-XXX | 400 |
| 71-E014-XX-XX | 434 | AV16-XXXXXXXXXX | 97 | PAN-234-XX | 269 | VE-0095-XXX | 388 |
| 71-E015-XX-XX | 434 | AV26-XXXXXXXXXX | 97 | QSXX-00XXAZXXXX | 40 | VE-0096-XXX | 386 |
| 71-E079-XX-XX | 434 | CDXX-05XXAZXXXX | 36 | RSXX-00XXAZXXXX | 40 | VE-0097-XXX | 389 |
| 71-E080-XX-XX | 434 | CFXX-00XXAZXXXX | 34 | SCXX-XXX-XXXXXX- XXX | 54 | VE-0112-XXX | 388 |
| 71-E083-XX-XX | 434 | CFXX-05XXAZXXXX | 36 | SQXX-XXX-XXXXXX- XXX | 54 | VE-0113-XXX | 389 |
| 71-E085-XX-XX | 434 | CPXX-05XXAZXXXX | 36 | SV-D0101 | 427 | VE-0114-XXX | 386 |
| 71-E086-XX-XX | 434 | CSXX-00XXAZXXXX | 34 | SV-D0102 | 427 | VE-0115-XXX | 387 |
| 71-E098-XX-XX | 420 | CSXX-05XXAZXXXX | 36 | TSXX-00XXAZXXXX | 40 | VE-0118-XXX | 390 |
| 71-E099-XX-XX | 420 | LSXX-00XXAZXXXX | 40 | VE-0016-XXX | 404 | VE-0119-XXX | 391 |
| 71-E101-XX-XX | 435 | OSXX-00XXAZXXXX | 40 | VE-0020-XXX | 408 | VE-0120-XXX | 390 |
| 71-E217-XX-XX | 434 | PAN-157-XX | 206, 313, 237 | VE-0022-XXX | 404 | VE-0121-XXX | 391 |
| 71-E218-XX-XX | 434 | PAN-161-XX | 237 | VE-0023-XXX | 404 | | |
| 71-E225-XX-XX | 434 | PAN-175-XX | 206, 313 | VE-0090-XXX | 402 | | |
| 71-E226-XX-XX | 434 | PAN-176-XX | 206, 313, 237 | | | | |
| 71-E300-XX-XX | 424 | | | | | | |

Información importante

Informação importante

Debido a la constante evolución de la tecnología LED, los datos técnicos de los productos pueden variar en el tiempo. Recomendamos consultar la ficha técnica en la página web (ledsc4.com) para disponer de versión actualizada.

Devido à constante evolução da tecnologia LED, os dados técnicos dos produtos podem variar no tempo. Recomendamos que consulte a ficha técnica na página web (ledsc4.com) para dispor de versão atualizada.

Todos los derechos reservados. Ninguna parte de este libro puede ser reproducida en ningún formato de papel o electrónico, sin el consentimiento previo del editor o de los propietarios de los derechos.

Todos os direitos reservados. Nenhuma parte deste livro pode ser reproduzida em nenhum formato de papel ou eletrônico, sem o consentimento prévio do editor ou dos titulares dos direitos.

Copyright © LedsC4 2026
All rights reserved

LedsC4

Afores s/n 25750 Torà
Lleida – Spain
+34 973 468 100
ledsc4@ledsc4.com

Customer Service

Spain

+34 973 468 101
spain@ledsc4.com

Europe

+34 973 468 102
europe@ledsc4.com

Latin America

+34 973 468 115
sudamerica@ledsc4.com

LedsC4 Centro Innovación Madrid

Pol. Industrial Ventorro del Cano
Calle Cercedilla 11 Nave1
28925 Alcorcón, Madrid

Colombia

+601 3441723

Poland

Leds Polska Sp. z o.o.
Ul. Kasztanowa 44
05-816Michalowice-Wies POLAND
+48 71 733 64 01
biuro@ledsc4.pl

United Kingdom

Free phone: 0808 234 2641
uk@ledsc4.com

Italy

Toll-free: 800 784 275
italia@ledsc4.com

Asia Pacific

+34 973 468 116
asiapacific@ledsc4.com

Canada

Toll-free: +1-866-5636666
CustomerServiceUS@ledsc4.com

Germany

ImWissenschaftspark
Deutschland GmbH
Munscheidstraße 14
45886 Gelsenkirchen GERMANY
+49 209 882 99 021
deutschland@ledsc4.com

Asia Pacific

8 Robinson Road
#03-00 ASO Building
048544 SINGAPORE
+34 973468116

France

+33 448 800 142
france@ledsc4.com

Portugal

+34 973 468 102
portugal@ledsc4.com

Benelux

+34 973 468 102
benelux@ledsc4.com

Africa

+34 973 468 116
africa@ledsc4.com

United States

Toll-free: +1-888-3710243
CustomerServiceUS@ledsc4.com

Middle East

Fortune Executive Tower
Cluster T - Office 204
Jumeirah Lake Towers
PO 336910 Dubai - UAE
+971 4458 4272

South Africa

LedsC4 PTY LTD
8 Neserton drive
Isandovale
Edenwale
Johannesburg 1609
+34 973 468 115
southafrica@ledsc4.com







Press

comunicacion@ledsc4.com

Suppliers

+ 34 973 468 113

new website
LedsC4.com

-  Instagram: [instagram.com/leds_c4/](https://www.instagram.com/leds_c4/)
-  Facebook: [facebook.com/ledsc4.sa](https://www.facebook.com/ledsc4.sa)
-  LinkedIn: [linkedin.com/company/ledsc4](https://www.linkedin.com/company/ledsc4)
-  YouTube: [youtube.com/ledsC4](https://www.youtube.com/ledsC4)
-  Pinterest: [pinterest.com/ledsc4](https://www.pinterest.com/ledsc4)
-  X: x.com/ledsc4



Este catálogo incluye todas las familias de luminarias y ventiladores para uso decorativo. Es el resultado de más de 50 años de experiencia ofreciendo luz de calidad, confortable y eficiente, para todo tipo de proyectos que buscan el mejor equilibrio entre diseño, tecnología, innovación, servicio y sostenibilidad.

Este catálogo inclui todas as famílias de luminárias e ventiladores para uso decorativo. É o resultado de mais de 50 anos de experiência oferecendo iluminação de qualidade, confortável e eficiente, para todo tipo de projetos que procuram o melhor equilíbrio entre design, tecnologia, inovação, serviço e sustentabilidade.

Light for better living

Ledsc4.com